



ELM446

50Hz Generator

Description

The ELM446 is an 8 pin digital divider integrated circuit, that provides both 50Hz and 1Hz outputs from a common 3.58MHz NTSC colourburst crystal.

Externally, the designer need only provide the crystal and two appropriate loading capacitors, as well as a suitably bypassed power supply. Internal oscillator circuits then use this reference frequency to precisely derive a stable 50Hz signal. For convenience, a complementary 50Hz signal is also provided. This signal is then further divided to provide a 1Hz signal output.

A reset input is provided to restart the internal counters, if desired. An active low signal on this pin will also force all of the outputs to an open or tristate condition.

Features

- Low power CMOS design
- Wide supply range - 3.0 to 5.5 volt operation
- 3.58MHz crystal controlled operation
- Generates both 50Hz and 1Hz references
- Low parts count
- Complementary 50Hz outputs
- High current drive outputs - up to 25 mA

Applications

- Stable 50Hz reference
- Master oscillator for clock / timekeeping functions
- Decimal based time reference for easier period calculations

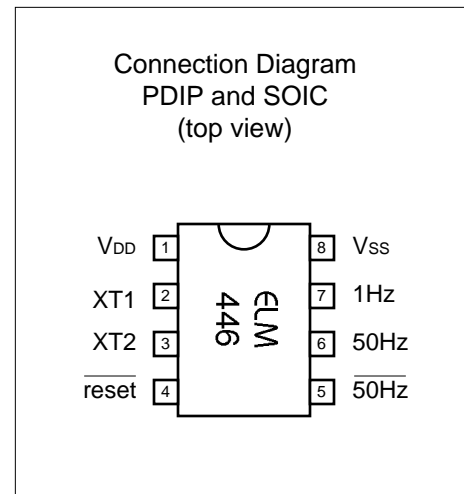

Block Diagram

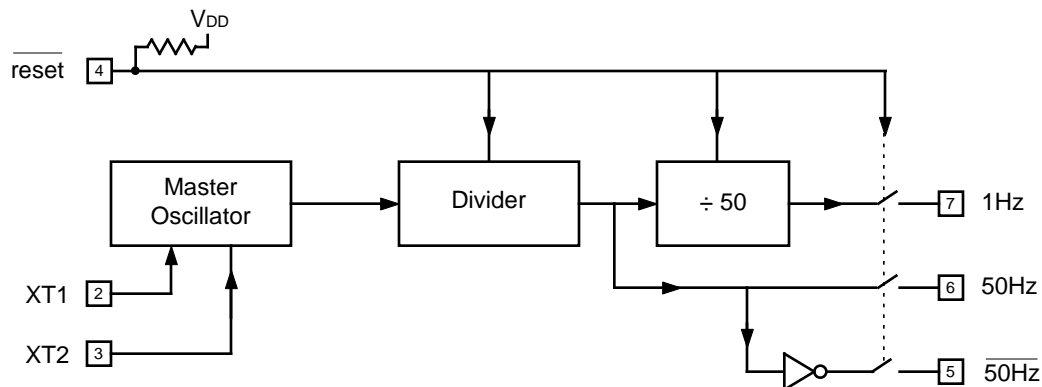



Pin Descriptions

V_{DD} (pin 1)

This pin is the positive supply pin, and should always be the most positive point in the circuit. Internal circuitry connected to this pin is used to provide power on reset of the microprocessor, so an external reset signal is not required. Refer to the Electrical Characteristics section for further information.

circuit by applying a logic low level to it. While held low, all outputs are placed in an open or tristate condition. If unused, this pin should be left open (as a pullup resistor is provided) or connected to V_{DD}.

XT1 (pin 2) and XT2 (pin 3)

A 3.579545MHz NTSC television colourburst crystal is connected between these two pins. Crystal loading capacitors (typically 27pF) will also normally be connected between each of the pins and V_{ss}.

50Hz (pin 6) and $\overline{50Hz}$ (pin 5)

These pins provide complementary 50Hz outputs. Each has a nominal 50% duty cycle.

$\overline{\text{reset}}$ (pin 4)

This pin can optionally be used to reset the

1Hz (pin 7)

The output on this pin is a 1Hz 50% duty cycle signal.

V_{ss} (pin 8)

Circuit common is connected to this pin. This is the most negative point in the circuit.

Ordering Information

These integrated circuits are available in either the 300 mil plastic DIP format, or in the 200 mil SOIC surface mount type of package. To order, add the appropriate suffix to the part number:

300 mil Plastic DIP..... ELM446P

200 mil SOIC..... ELM446SM

Absolute Maximum Ratings

Storage Temperature..... -65°C to +150°C

Ambient Temperature with Power Applied..... -40°C to +85°C

Voltage on V_{DD} with respect to V_{ss}..... 0 to +7.5V

Voltage on any other pin with respect to V_{ss}..... -0.6V to (V_{DD} + 0.6V)

Note:

Stresses beyond those listed here will likely damage the device. These values are given as a design guideline only. The ability to operate to these levels is neither inferred nor recommended.

All rights reserved. Copyright ©1999 Elm Electronics. Every effort is made to verify the accuracy of information provided in this document, but no representation or warranty can be given and no liability assumed by Elm Electronics with respect to the accuracy and/or use of any products or information described in this document. Elm Electronics will not be responsible for any patent infringements arising from the use of these products or information, and does not authorize or warrant the use of any Elm Electronics product in life support devices and/or systems. Elm Electronics reserves the right to make changes to the device(s) described in this document in order to improve reliability, function, or design.



Electrical Characteristics

All values are for operation at 25°C and a 5V supply, unless otherwise noted. For further information, refer to note 1 below.

Characteristic	Minimum	Typical	Maximum	Units	Conditions
Supply Voltage, V_{DD}	3.0	5.0	5.5	V	
V_{DD} rate of rise	0.05			V/ms	see note 2
Average Supply Current, I_{DD}		0.60	2.4	mA	$V_{DD} = 5V$
		0.35	2.4	mA	$V_{DD} = 3V$
Reset pin internal pullup resistance	300	470	600	K	see note 3
Input low voltage	V_{SS}		$0.15 V_{DD}$	V	
Input high voltage	$0.85 V_{DD}$		V_{DD}	V	
Output low voltage			0.6	V	Current (sink) = 8.7mA
Output high voltage	$V_{DD} - 0.7$			V	Current (source) = 5.4mA
Output Duty Cycle		50		%	any output

Notes:

1. This integrated circuit is produced with a Microchip Technology Inc.'s PIC12C5XX as the core embedded microcontroller. For further device specifications, and possibly clarification of those given, please refer to the appropriate Microchip documentation.
2. This spec must be met in order to ensure that a correct power on reset occurs. It is quite easily achieved using most common types of supplies, but may be violated if one uses a slowly varying supply voltage, as may be obtained through direct connection to solar cells, or some charge pump circuits.
3. The value of the pullup resistance is supply and temperature dependent.

Example Application

Operation of the ELM446 is straightforward, requiring little explanation. Typically it is connected in a circuit as shown at the right. Optionally, one might replace one of the fixed value capacitors with a variable one, in order to be able to trim the oscillator frequency for greater accuracy. As usual, it is also good practice to place a bypass capacitor across the power supply as well.

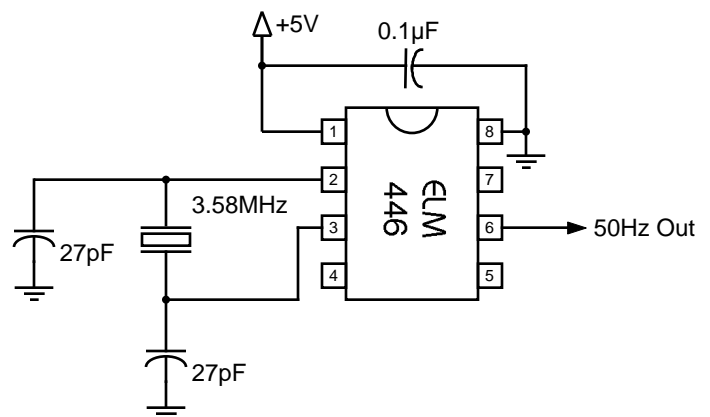

This datasheet has been downloaded from:

www.DatasheetCatalog.com

Datasheets for electronic components.