

QAMLINK® HIGH-PERFORMANCE, SINGLE-CHIP CABLE MODEM

BCM3345 FEATURES

- State-of-the-art, single-chip DOCSIS/EuroDOCSIS 1.0/1.1 cable modem providing unprecedented levels of integration and performance
- The BCM3345 integrates:
 - Advanced QAMLink® transceiver supporting Annex A/B/C operation
 - DOCSIS/EuroDOCSIS 1.0/1.1 MAC
 - High-performance, 140-MHz MIPS-32 CPU
 - Advanced QAMLink, downstream demodulator, supporting 4/16/32/64/128/256 QAM
 - Advanced QAMLink upstream modulator, supporting 2/4/8/16 QAM
 - Upstream power amplifier
 - 10/100 Ethernet MAC/PHY with MII interface
 - Single 28MHz reference crystal
 - USB 1.1 slave port with integrated transceiver
 - 100-MHz SDRAM interface
- Advanced RF and control interface to silicon tuner for DOCSIS/EuroDOCSIS solutions
- EJTAG embedded ICE support
- On-chip support for Propane™ packet acceleration
- 1.8/3.3 volt operation
- 312-pin PBGA package

SUMMARY OF BENEFITS

- Results in simplified BOM—reduces component count, improves assembly process and results in lowest overall system cost for DOCSIS/ EuroDOCSIS 1.0/1.1 cable modem.
- DOCSIS/EuroDOCSIS 1.0/1.1 MAC is compatible with existing Cable Modem application code, resulting in minimum time to market.
- 140-MHz MIPS-32 CPU provides 66% improvement in packet throughput over prior generations.
- Advanced QAMLink™ modulator/demodulator provides superior performance in noisy plant environments.
- On-chip Propane supports DOCSIS/EuroDOCSIS based packet acceleration.
- Integrated 10/100 Ethernet MAC/PHY with MII eliminates the need for external Ethernet support.
- Fully USB 1.1 compliant interface enables simple Plug and Play installations.
- EJTAG embedded ICE support is compatible with existing MIPS32 development tools, improving software development and testing.

High-Performance, Single-Chip DOCSIS/EuroDOCSIS 1.1 Cable Modem

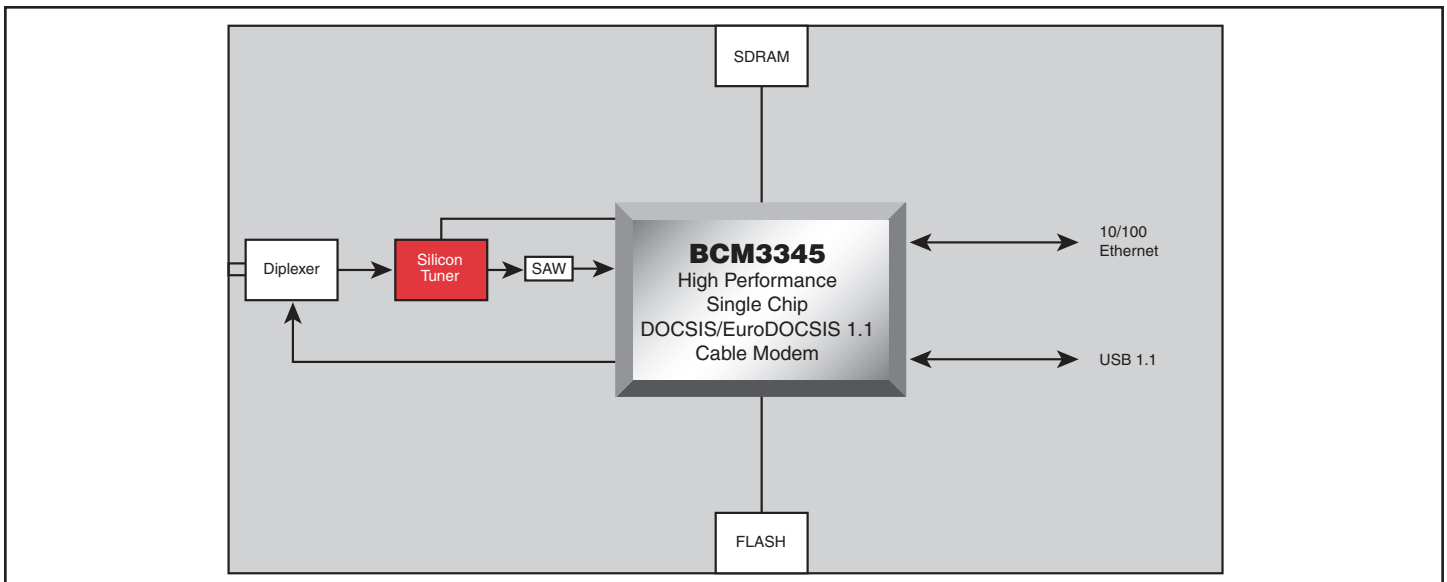

BCM3345 OVERVIEW

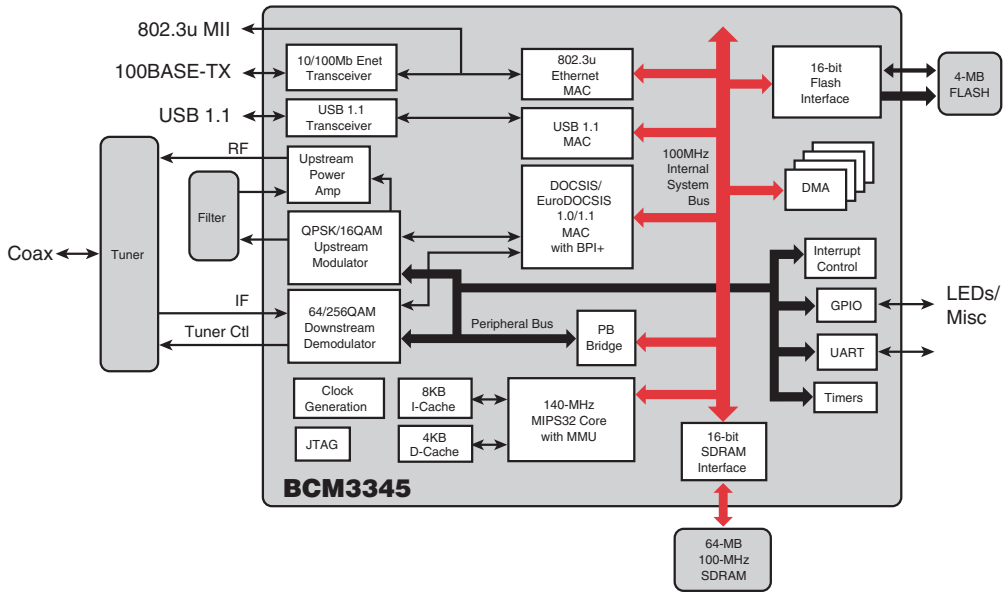

The **BCM3345** combines an advanced QAM receiver; an advanced QAM transmitter; a complete DOCSIS/EuroDOCSIS Media Access Controller (MAC); a 140-MHz MIPS32 communication processor; a 16-bit, 100-MHz SDRAM interface; 10/100 Ethernet MAC with integrated transceiver and MII interface; and a USB 1.1 controller with integrated transceiver.

The QAM receiver directly samples a tuner output with a 10-bit A/D converter and input ACG amplifier. The receiver digitally resamples and demodulates the signal with recovered clock and carrier timing, filters and equalizes the data, and passes soft decisions to an ITU-T J.83 Annex A/B/C compatible decoder. A 40-tap adaptive decision feedback equalizer is implemented. The receiver supports variable symbol rate 64/256 QAM FEC decoding. The final received data stream is delivered in a serial MPEG-2 transport format. All gain, clock, and carrier, acquisition and tracking loops are integrated in the QAM receiver.

The upstream transmitter takes burst or continuous data, provides FEC encoding and pre-equalization for DOCSIS/EuroDOCSIS applications, filters and applies QPSK or QAM16 modulation to the data stream, amplifies the signal through the integrated upstream power amplifier, and provides a direct 0–65 MHz analog output.

Broadcom®, the pulse logo, QAMLink®, and Connecting everything® are trademarks of Broadcom Corporation and/or its subsidiaries in the United States and certain other countries. All other trademarks are the property of their respective owners.

Connecting
everything®

BROADCOM CORPORATION
16215 Alton Parkway, P.O. Box 57013
Irvine, California 92619-7013

© 2002 by BROADCOM CORPORATION. All rights reserved.
3345-PB03-403-R 11.22.02

The **BCM3345** Media Access Controller (MAC) includes all the features required for full DOCSIS/EuroDOCSIS 1.0/1.1 compliance, including full support for baseline privacy (BPI+) encryption and decryption. Single user support includes four SIDS in downstream, four DA perfect match filters, a 64-entry CAM for multicast/unicast hash filter, and four independent upstream queues for simultaneous support of QoS and BE traffic. To enhance operational support, the **BCM3345** provides extended Network Management MIB/Diagnostic features, as well as immediate UCC (on-the-fly) using independent resets for downstream and upstream and both individual queue reset/flush for upstream queues. The **BCM3345** uses advanced Propane techniques to provide packet acceleration to significantly improve upstream channel utilization.

With the incorporation of an upstream power amplifier, the **BCM3345** allows a complete cable modem to be assembled with a minimal set of external components. When used with the silicon tuner, Broadcom offers the lowest price solution for a high-performance, single user Cable Modem.

Ordering information:

BCM3345KPB

DOCSIS/EuroDOCSIS applications



Phone: 949-450-8700
FAX: 949-450-8710
Email: info@broadcom.com
Web: www.broadcom.com

This datasheet has been downloaded from:

www.DatasheetCatalog.com

Datasheets for electronic components.