

HIGH-VOLTAGE OPERATIONAL AMPLIFIER

DESCRIPTION

The SG143 is a general-purpose high-voltage operational amplifier featuring operation to $\pm 40V$ and overvoltage protection up to $\pm 40V$. Increased slew rate, together with higher common-mode and supply rejection, insure improved performance at high supply voltages. Operating characteristics are independent of supply voltage and temperature. These devices are intended for use in high voltage applications where common-mode input ranges, high output voltage swings, and low input currents are required. Also, they are internally compensated and are pin compatible with industry standard operational amplifiers.

FEATURES

- $\pm 4.0V$ to $\pm 40V$ supply voltage range
- $\pm 37V$ output voltage swing
- $\pm 24V$ common-mode voltages
- Overvoltage protection
- Output short circuit protection

HIGH RELIABILITY FEATURES-SG143

- ◆ Available to MIL-STD-883 and DESC SMD
- ◆ LMI level "S" processing available

CIRCUIT SCHEMATIC

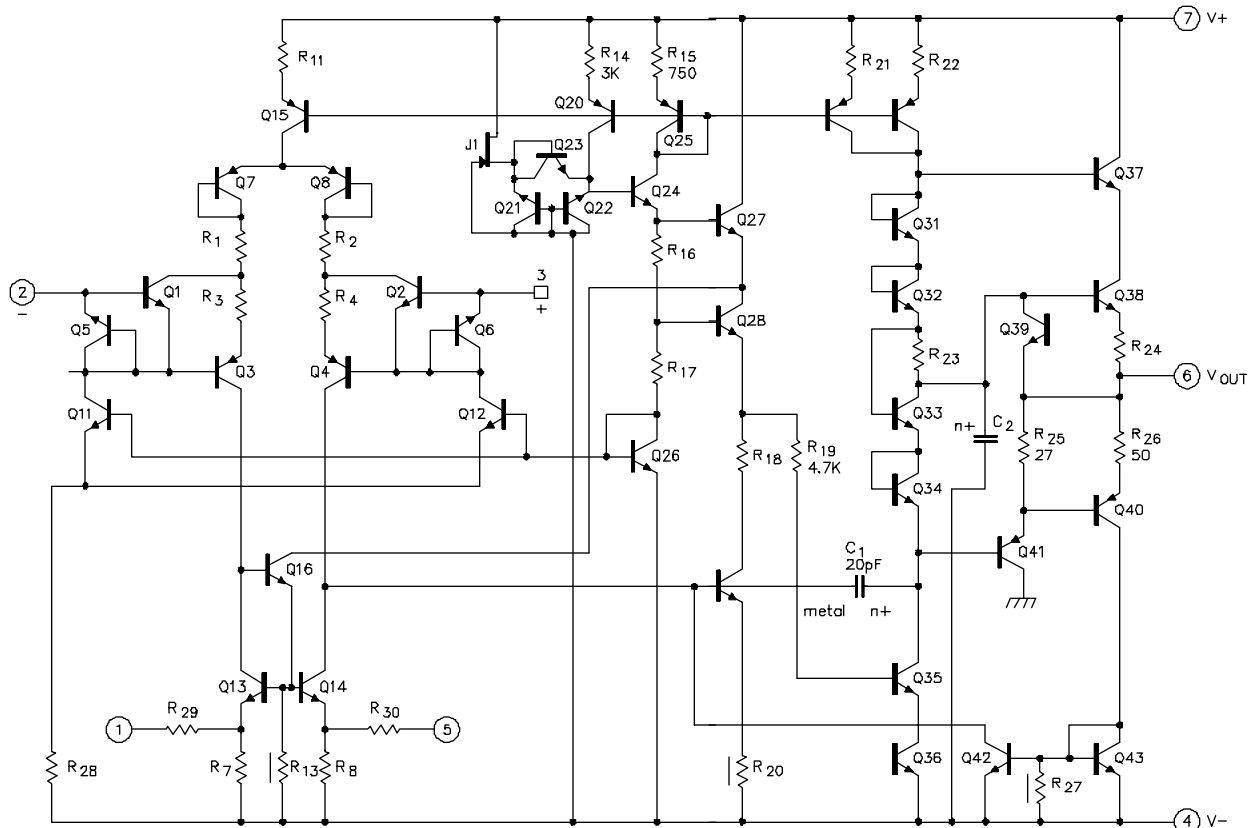

ABSOLUTE MAXIMUM RATINGS (Note 1)

Supply Voltage	
SG143	±40V
Input Voltage	
SG143	±40V
Differential Input Voltage	$\pm(V^+ + V^- - 3) V$

Output Short Circuit Duration	5 sec
Operating Junction Temperature	
Hermetic (T, Y-Package)	150°C
Storage Temperature Range	-65°C to 150°C
Lead Temperature (Soldering, 10 Seconds)	300°C

Note 1. Exceeding these ratings could cause damage to the device.

THERMAL DATA

T Package:

Thermal Resistance-Junction to Case, θ_{JC}	25°C/W
Thermal Resistance-Junction to Ambient, θ_{JA}	130°C/W

Y Package:

Thermal Resistance-Junction to Case, θ_{JC}	50°C/W
Thermal Resistance-Junction to Ambient, θ_{JA}	130°C/W

Note A. Junction Temperature Calculation: $T_J = T_A + (P_D \times \theta_{JA})$.

Note B. The above numbers for θ_{JC} are maximums for the limiting thermal resistance of the package in a standard mounting configuration. The θ_{JA} numbers are meant to be guidelines for the thermal performance of the device/pc-board system. All of the above assume no ambient airflow.

RECOMMENDED OPERATING CONDITIONS (Note 2)

Supply Voltage	
SG143	±28V

Input Voltage	
SG143	±28V
Operating Ambient Temperature Range (T_J)	
SG143	-55°C to 125°C

Note 2. Range over which the device is functional.

ELECTRICAL CHARACTERISTICS

(Unless otherwise specified, these specifications apply for the operating ambient temperature of 25°C and over the recommended supply voltage range. Low duty cycle pulse testing techniques are used which maintains junction and case temperatures equal to the ambient temperature.)

Parameter	Test Conditions	SG143			Units
		Min.	Typ.	Max.	
Input Offset Voltage			2.0	5.0	mV
Input Offset Current	$T_A = T_{MIN}$ to T_{MAX}			6.0	mV
			1.0	3.0	nA
Input Bias Current	$T_A = T_{MAX}$ $T_A = T_{MIN}$ *			4.5	nA
				7.0	nA
			8.0	20	nA
Large Signal Voltage Gain	$T_A = T_{MIN}$ to T_{MAX} $R_L = 100K\Omega, V_{OUT} = \pm 10V$			35	nA
			100	180	V/mV
Common-Mode Rejection	$T_A = T_{MIN}$ to T_{MAX}				V/mV
			50		V/mV
Power Supply Rejection		80	110		dB
Input Common Mode Range (Peak)			15	100	$\mu V/V$
Unity Gain Bandwidth		±24	±25		V
Slew Rate			1.0		MHz
Supply Current	$R_L = 5K\Omega$		2.5		V/ μs
Output Voltage Swing				4.0	mA
Short Circuit Current		±22			V
			20		mA

CHARACTERISTIC CURVES

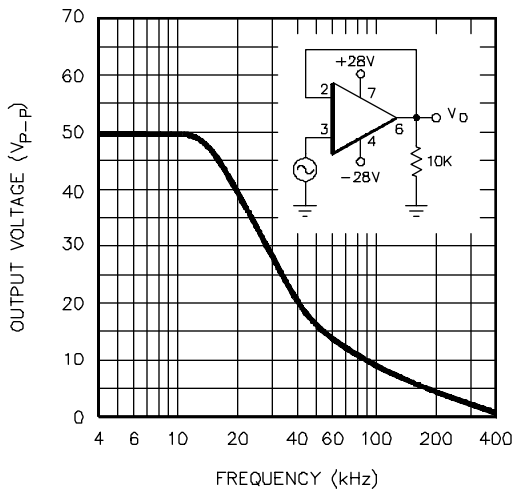

FIGURE 1. POWER BANDWIDTH

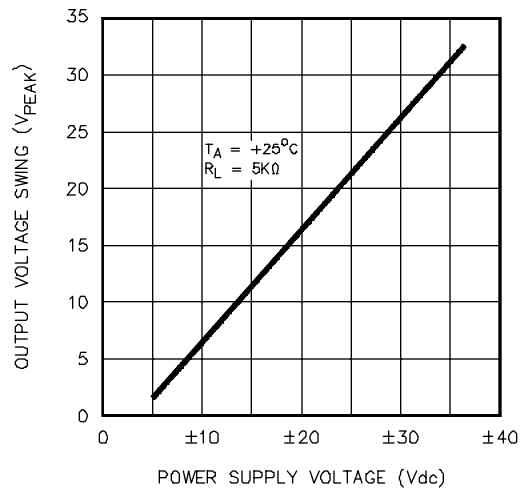

FIGURE 2. PEAK OUTPUT VOLTAGE SWING VS. POWER SUPPLY VOLTAGE

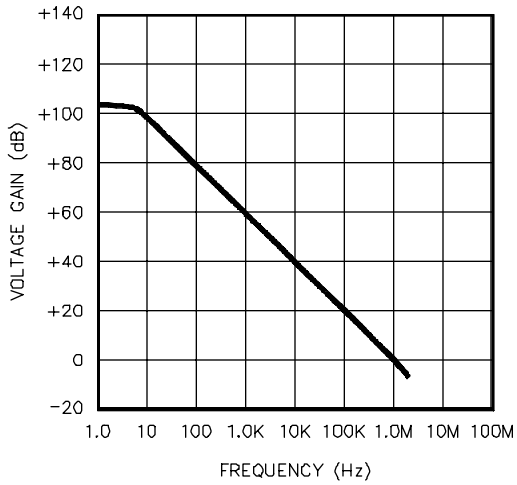

FIGURE 3. OPEN-LOOP FREQUENCY RESPONSE

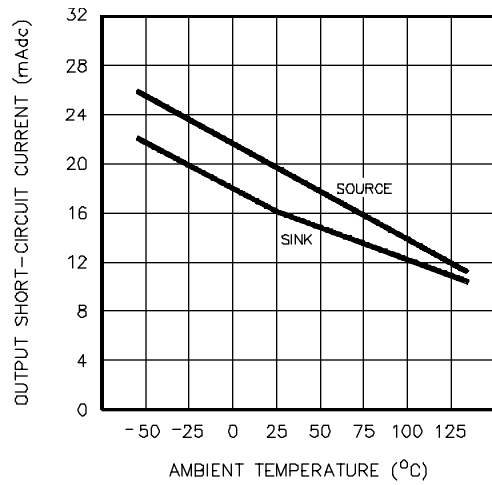

FIGURE 4. OUTPUT SHORT-CIRCUIT CURRENT VS. TEMPERATURE

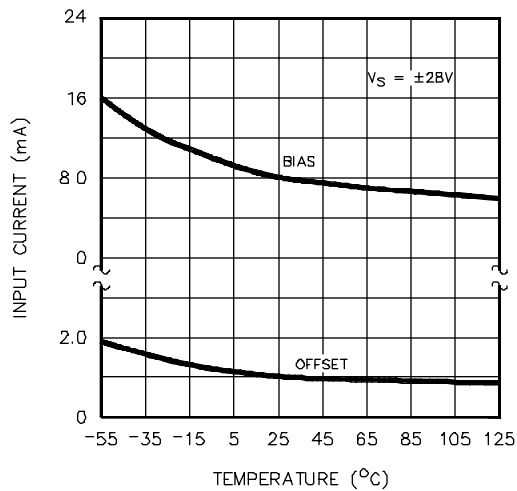

FIGURE 5. INPUT CURRENT

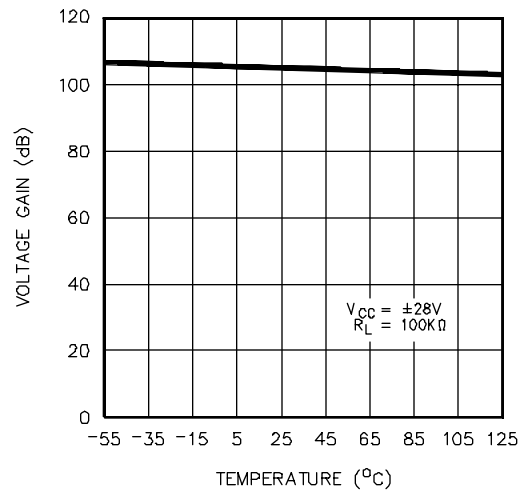

FIGURE 6. VOLTAGE GAIN

CHARACTERISTIC CURVES (continued)

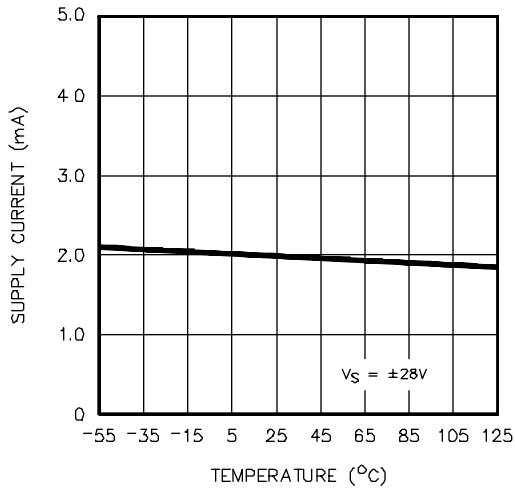

FIGURE 7. SUPPLY CURRENT

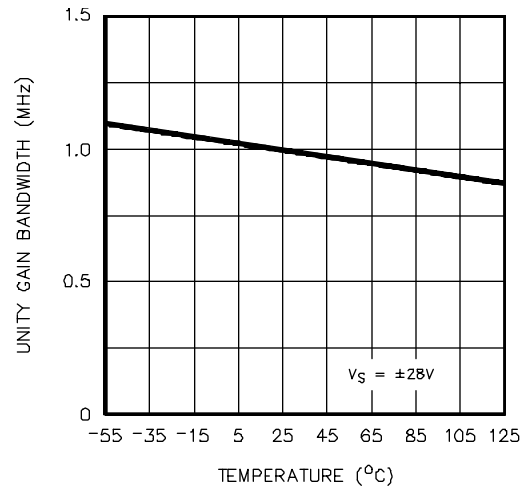

FIGURE 8. UNITY GAIN BANDWIDTH

TYPICAL APPLICATIONS

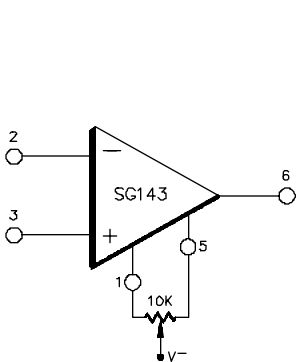

FIGURE 9 - VOLTAGE OFFSET NULL CIRCUIT

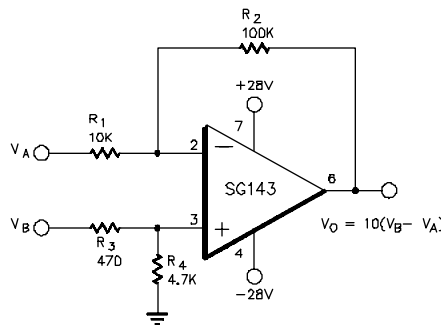
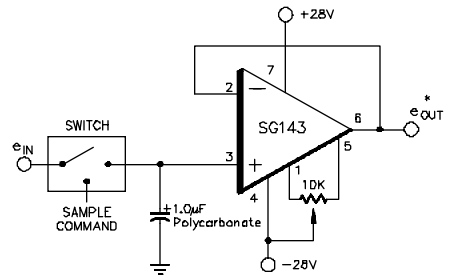

FIGURE 10 - DIFFERENTIAL AMPLIFIER WITH ±20V COMMON-MODE INPUT VOLTAGE RANGE



* Drift due to bias current is typically 8mV/s

FIGURE 11 - LOW-DRIFT SAMPLE AND HOLD

CONNECTION DIAGRAMS & ORDERING INFORMATION (See Notes Below)

Package	Part No.	Ambient Temperature Range	Connection Diagram
8-PIN METAL CAN T - PACKAGE	SG143T/883B SG143T/DESC SG143T	-55°C to 125°C -55°C to 125°C -55°C to 125°C	
8-PIN CERAMIC DIP Y - PACKAGE	SG143Y/883B SG143Y/DESC SG143Y	-55°C to 125°C -55°C to 125°C -55°C to 125°C	

Note 1. Contact factory for JAN and DESC product availability.
 Note 2. All packages are viewed from the top.

This datasheet has been downloaded from:

www.DatasheetCatalog.com

Datasheets for electronic components.