



# +1.2V to +5.5V, ±15kV ESD-Protected, 0.1µA, 35Mbps, 8-Channel Level Translators

## General Description

The MAX3000E/MAX3001E/MAX3002–MAX3012 8-channel level translators provide the level shifting necessary to allow data transfer in a multivoltage system. Externally applied voltages,  $V_{CC}$  and  $V_L$ , set the logic levels on either side of the device. Logic signals present on the  $V_L$  side of the device appear as a higher voltage logic signal on the  $V_{CC}$  side of the device, and vice-versa.

The MAX3000E/MAX3001E/MAX3002/MAX3004–MAX3012 feature an EN input that, when low, reduces the  $V_{CC}$  and  $V_L$  supply currents to  $<2\mu\text{A}$ . The MAX3000E/MAX3001E also have  $\pm 15\text{kV}$  ESD protection on the I/O  $V_{CC}$  side for greater protection in applications that route signals externally. The MAX3000E operates at a guaranteed data rate of 230kbps. The MAX3001E operates at a guaranteed data rate of 4Mbps. The MAX3002–MAX3012 operate at a guaranteed data rate of 20Mbps over the entire specified operating voltage range.

The MAX3000E/MAX3001E/MAX3002–MAX3012 accept  $V_L$  voltages from +1.2V to +5.5V and  $V_{CC}$  voltages from +1.65V to +5.5V, making them ideal for data transfer between low-voltage ASICs/PLDs and higher voltage systems. The MAX3000E/MAX3001E/MAX3002–MAX3012 are available in 20-pin UCSP™ and 20-pin TSSOP packages.

## Applications

- Cellphones
- SPI™ and MICROWIRE™ Level Translation
- Low-Voltage ASIC Level Translation
- Smart Card Readers
- Cellphone Cradles
- Portable POS Systems
- Portable Communication Devices
- Low-Cost Serial Interfaces
- GPS
- Telecommunications Equipment

UCSP is a trademark of Maxim Integrated Products, Inc.

SPI is a trademark of Motorola, Inc.

MICROWIRE is a trademark of National Semiconductor.

## Features

- ◆ Guaranteed Data Rate Options
  - 230kbps (MAX3000E)
  - 4Mbps (MAX3001E)
  - 20Mbps (MAX3002–MAX3012)
- ◆ Bidirectional Level Translation (MAX3000E/MAX3001E/MAX3002/MAX3003)
- ◆ Unidirectional Level Translation (MAX3004–MAX3012)
- ◆ Operation Down to +1.2V on  $V_L$
- ◆  $\pm 15\text{kV}$  ESD Protection on I/O  $V_{CC}$  Lines (MAX3000E/MAX3001E)
- ◆ Ultra-Low 0.1µA Supply Current in Shutdown
- ◆ Low Quiescent Current ( $<10\mu\text{A}$ )
- ◆ UCSP and TSSOP Packages

## Ordering Information

PART	TEMP RANGE	PIN-PACKAGE
MAX3000EEUP	-40°C to +85°C	20 TSSOP
MAX3000EEBP-T*	-40°C to +85°C	4 x 5 UCSP

\*Future product—contact factory for availability.

Ordering Information continued at end of data sheet.

## Typical Operating Circuit

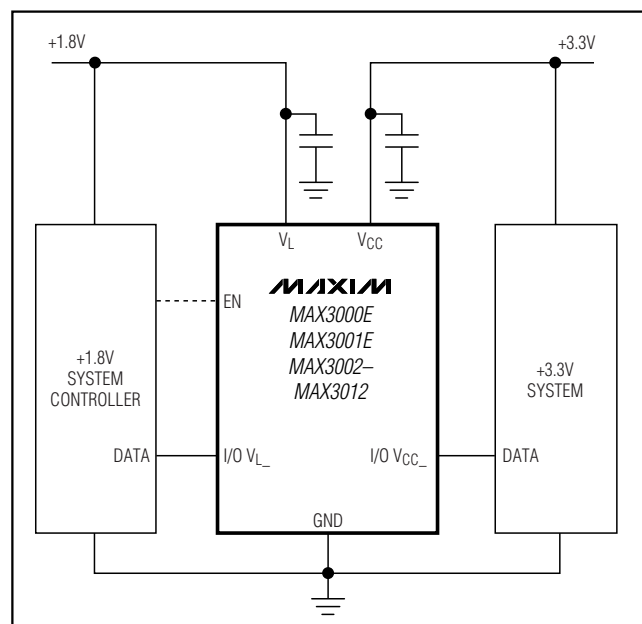

Pin Configurations and Functional Diagrams appear at end of data sheet.



# +1.2V to +5.5V, ±15kV ESD-Protected, 0.1µA, 35Mbps, 8-Channel Level Translators

## ABSOLUTE MAXIMUM RATINGS

All Voltages Referenced to GND

V <sub>CC</sub> .....	-0.3V to +6V
V <sub>L</sub> .....	-0.3V to +6V
I/O V <sub>CC_</sub> .....	-0.3V to (V <sub>CC</sub> + 0.3V)
I/O V <sub>L_</sub> .....	-0.3V to (V <sub>L</sub> + 0.3V)
EN, EN A/B .....	-0.3V to +6V
Short-Circuit Duration I/O V <sub>L_</sub> , I/O V <sub>CC_</sub> to GND .....	Continuous
Continuous Power Dissipation (T <sub>A</sub> = +70°C)	
20-Pin TSSOP (derate 7.0mW/°C above +70°C) .....	559mW
20-Pin UCSP (derate 10mW/°C above +70°C) .....	800mW

Operating Temperature Ranges

MAX3001EAUP .....	-40°C to +125°C
MAX300_EE_P .....	-40°C to +85°C
MAX30_E_P .....	-40°C to +85°C
Junction Temperature .....	+150°C
Storage Temperature Range .....	-65°C to +150°C
Lead Temperature (soldering, 10s) .....	+300°C

Stresses beyond those listed under "Absolute Maximum Ratings" may cause permanent damage to the device. These are stress ratings only, and functional operation of the device at these or any other conditions beyond those indicated in the operational sections of the specifications is not implied. Exposure to absolute maximum rating conditions for extended periods may affect device reliability.

## ELECTRICAL CHARACTERISTICS

(V<sub>CC</sub> = +1.65V to +5.5V, V<sub>L</sub> = +1.2V to V<sub>CC</sub>, EN = V<sub>L</sub> (MAX3000E/MAX3001E/MAX3002/MAX3004-MAX3012), EN A/B = V<sub>L</sub> or 0 (MAX3003), T<sub>A</sub> = T<sub>MIN</sub> to T<sub>MAX</sub>. Typical values are at V<sub>CC</sub> = +1.65V, V<sub>L</sub> = +1.2V, and T<sub>A</sub> = +25°C.) (Notes 1, 2)

PARAMETER	SYMBOL	CONDITIONS	MIN	TYP	MAX	UNITS
<b>POWER SUPPLIES</b>						
V <sub>L</sub> Supply Range	V <sub>L</sub>		1.2		5.5	V
V <sub>CC</sub> Supply Range	V <sub>CC</sub>		1.65		5.50	V
Supply Current from V <sub>CC</sub>	I <sub>QVCC</sub>	I/O V <sub>CC_</sub> = 0, I/O V <sub>L_</sub> = 0 or I/O V <sub>CC_</sub> = V <sub>CC</sub> , I/O V <sub>L_</sub> = V <sub>L</sub> , MAX3000E/MAX3002-MAX3012		0.1	10	µA
		I/O V <sub>CC_</sub> = 0, I/O V <sub>L_</sub> = 0 or I/O V <sub>CC_</sub> = V <sub>CC</sub> , I/O V <sub>L_</sub> = V <sub>L</sub> , MAX3001E		0.1	50	
Supply Current from V <sub>L</sub>	I <sub>QVL</sub>	I/O V <sub>CC_</sub> = 0, I/O V <sub>L_</sub> = 0 or I/O V <sub>CC_</sub> = V <sub>CC</sub> , I/O V <sub>L_</sub> = V <sub>L</sub> , MAX3000E/MAX3002-MAX3012		0.1	10	µA
		I/O V <sub>CC_</sub> = 0, I/O V <sub>L_</sub> = 0 or I/O V <sub>CC_</sub> = V <sub>CC</sub> , I/O V <sub>L_</sub> = V <sub>L</sub> , MAX3001E		0.1	50	
V <sub>CC</sub> Shutdown Supply Current	I <sub>SHDN-VCC</sub>	T <sub>A</sub> = +25°C, EN = 0, MAX3000E/MAX3001E/MAX3002/ MAX3004-MAX3012		0.1	2	µA
		T <sub>A</sub> = +25°C, EN A/B = 0, MAX3003		0.1	2	
V <sub>L</sub> Shutdown Supply Current	I <sub>SHDN-VL</sub>	T <sub>A</sub> = +25°C, EN = 0, MAX3000E/MAX3001E/MAX3002/ MAX3004-MAX3012		0.1	2	µA
		T <sub>A</sub> = +25°C, EN A/B = 0, MAX3003		0.1	2	

# +1.2V to +5.5V, ±15kV ESD-Protected, 0.1µA, 35Mbps, 8-Channel Level Translators

## ELECTRICAL CHARACTERISTICS (continued)

(V<sub>CC</sub> = +1.65V to +5.5V, V<sub>L</sub> = +1.2V to V<sub>CC</sub>, EN = V<sub>L</sub> (MAX3000E/MAX3001E/MAX3002/MAX3004–MAX3012), EN A/B = V<sub>L</sub> or 0 (MAX3003), T<sub>A</sub> = T<sub>MIN</sub> to T<sub>MAX</sub>. Typical values are at V<sub>CC</sub> = +1.65V, V<sub>L</sub> = +1.2V, and T<sub>A</sub> = +25°C.) (Notes 1, 2)

PARAMETER	SYMBOL	CONDITIONS	MIN	TYP	MAX	UNITS
I/O V <sub>CC_</sub> Three-State Output Leakage Current		T <sub>A</sub> = +25°C, EN = 0, MAX3000E/MAX3001E/MAX3002/MAX3004–MAX3012		0.1	2	µA
		T <sub>A</sub> = +25°C, EN A/B = 0, MAX3003		0.1	2	
I/O V <sub>L_</sub> Three-State Output Leakage Current		EN A/B = 0, MAX3003		0.1	2	µA
I/O V <sub>L_</sub> Pulldown Resistance During Shutdown		EN = 0, MAX3000E/MAX3001E/MAX3002/MAX3004–MAX3012	4.59		8.30	kΩ
EN or EN A/B Input Leakage Current		T <sub>A</sub> = +25°C			1	µA
<b>LOGIC-LEVEL THRESHOLDS</b>						
I/O V <sub>L_</sub> Input Voltage High Threshold	V <sub>IHL</sub>				V <sub>L</sub> - 0.4	V
I/O V <sub>L_</sub> Input Voltage Low Threshold	V <sub>ILL</sub>		0.4			V
I/O V <sub>CC_</sub> Input Voltage High Threshold	V <sub>IHC</sub>				V <sub>CC</sub> - 0.4	V
I/O V <sub>CC_</sub> Input Voltage Low Threshold	V <sub>ILC</sub>		0.4			V
EN, EN A/B Input Voltage High Threshold	V <sub>IH</sub>				V <sub>L</sub> - 0.4	V
EN, EN A/B Input Voltage Low Threshold	V <sub>IL</sub>		0.4			V
I/O V <sub>L_</sub> Output Voltage High	V <sub>OHL</sub>	I/O V <sub>L_</sub> source current = 20µA, I/O V <sub>CC_</sub> ≥ V <sub>CC</sub> - 0.4V	V <sub>L</sub> - 0.4			V
I/O V <sub>L_</sub> Output Voltage Low	V <sub>OLL</sub>	I/O V <sub>L_</sub> sink current = 20µA, I/O V <sub>CC_</sub> ≤ 0.4V			0.4	V
I/O V <sub>CC_</sub> Output Voltage High	V <sub>OHC</sub>	I/O V <sub>CC_</sub> source current = 20µA, I/O V <sub>L_</sub> ≥ V <sub>L</sub> - 0.4V	V <sub>CC</sub> - 0.4			V
I/O V <sub>CC_</sub> Output Voltage Low	V <sub>OLC</sub>	I/O V <sub>CC_</sub> sink current = 20µA, I/O V <sub>L_</sub> ≤ 0.4V			0.4	V
<b>ESD PROTECTION</b>						
I/O V <sub>CC_</sub>		Human Body Model, MAX3000E/MAX3001E		±15		kV

MAX3000E/MAX3001E/MAX3002–MAX3012

# +1.2V to +5.5V, ±15kV ESD-Protected, 0.1µA, 35Mbps, 8-Channel Level Translators

## TIMING CHARACTERISTICS

( $V_{CC} = +1.65V$  to  $+5.5V$ ,  $V_L = +1.2V$  to  $V_{CC}$ ,  $EN = V_L$  (MAX3000E/MAX3001E/MAX3002/MAX3004-MAX3012),  $EN\ A/B = V_L$  or 0 (MAX3003),  $T_A = T_{MIN}$  to  $T_{MAX}$ . Typical values are at  $V_{CC} = +1.65V$ ,  $V_L = +1.2V$ , and  $T_A = +25^\circ C$ .) (Notes 1, 2)

PARAMETER	SYMBOL	CONDITIONS	MIN	TYP	MAX	UNITS
I/O $V_{CC}$ _ Rise Time	$t_{RVCC}$	$R_S = 50\Omega$ , $C_{VCC} = 50pF$ , MAX3000E, Figures 1a, 1b	400	800	1200	ns
		$R_S = 50\Omega$ , $C_{VCC} = 50pF$ , MAX3001E, Figures 1a, 1b		25	50	
		$R_S = 50\Omega$ , $C_{VCC} = 50pF$ , MAX3002-MAX3012, Figures 1a, 1b			15	
I/O $V_{CC}$ _ Fall Time	$t_{FVCC}$	$R_S = 50\Omega$ , $C_{VCC} = 50pF$ , MAX3000E, Figures 1a, 1b	400	800	1200	ns
		$R_S = 50\Omega$ , $C_{VCC} = 50pF$ , MAX3001E, Figures 1a, 1b		25	50	
		$R_S = 50\Omega$ , $C_{VCC} = 50pF$ , MAX3002-MAX3012, Figures 1a, 1b			15	
I/O $V_L$ _ Rise Time	$t_{RVL}$	$R_S = 50\Omega$ , $C_{VL} = 50pF$ , MAX3000E, Figures 2a, 2b	400	800	1200	ns
		$R_S = 50\Omega$ , $C_{VL} = 50pF$ , MAX3001E, Figures 2a, 2b		25	50	
		$R_S = 50\Omega$ , $C_{VL} = 15pF$ , MAX3002-MAX3012, Figures 2a, 2b			15	
I/O $V_L$ _ Fall Time	$t_{FVL}$	$R_S = 50\Omega$ , $C_{VL} = 50pF$ , MAX3000E, Figures 2a, 2b	400	800	1200	ns
		$R_S = 50\Omega$ , $C_{VL} = 50pF$ , MAX3001E, Figures 2a, 2b		25	65	
		$R_S = 50\Omega$ , $C_{VL} = 15pF$ , MAX3002-MAX3012, Figures 2a, 2b			15	
Propagation Delay (Driving I/O $V_L$ _)	I/O $V_L$ -VCC	$R_S = 50\Omega$ , $C_{VCC} = 50pF$ , MAX3000E, Figures 1a, 1b			1000	ns
		$R_S = 50\Omega$ , $C_{VCC} = 50pF$ , MAX3001E, Figures 1a, 1b			50	
		$R_S = 50\Omega$ , $C_{VCC} = 50pF$ , MAX3002-MAX3012, Figures 1a, 1b			20	
Propagation Delay (Driving I/O $V_{CC}$ _)	I/O $V_{CC}$ -VL	$R_S = 50\Omega$ , $C_{VL} = 50pF$ , MAX3000E, Figures 2a, 2b			1000	ns
		$R_S = 50\Omega$ , $C_{VL} = 50pF$ , MAX3001E, Figures 2a, 2b			50	
		$R_S = 50\Omega$ , $C_{VL} = 15pF$ , MAX3002-MAX3012, Figures 2a, 2b			20	

**Note 1:** All units are 100% production tested at  $T_A = +25^\circ C$ . Limits over the operating temperature range are guaranteed by design and not production tested.

**Note 2:** For normal operation, ensure that  $V_L < (V_{CC} + 0.3V)$ . During power-up,  $V_L > (V_{CC} + 0.3V)$  does not damage the device.

# +1.2V to +5.5V, ±15kV ESD-Protected, 0.1µA, 35Mbps, 8-Channel Level Translators

**MAX3000E/MAX3001E/MAX3002-MAX3012**

## TIMING CHARACTERISTICS (continued)

(V<sub>CC</sub> = +1.65V to +5.5V, V<sub>L</sub> = +1.2V to V<sub>CC</sub>, EN = V<sub>L</sub> (MAX3000E/MAX3001E/MAX3002/MAX3004-MAX3012), EN A/B = V<sub>L</sub> or 0 (MAX3003), T<sub>A</sub> = T<sub>MIN</sub> to T<sub>MAX</sub>. Typical values are at V<sub>CC</sub> = +1.65V, V<sub>L</sub> = +1.2V, and T<sub>A</sub> = +25°C.) (Notes 1, 2)

PARAMETER	SYMBOL	CONDITIONS	MIN	TYP	MAX	UNITS
Channel-to-Channel Skew	t <sub>SKEW</sub>	R <sub>S</sub> = 50Ω, C <sub>VCC</sub> = 50pF, C <sub>VL</sub> = 50pF, MAX3000E			500	ns
		R <sub>S</sub> = 50Ω, C <sub>VCC</sub> = 50pF, C <sub>VL</sub> = 50pF, MAX3001E			10	
		R <sub>S</sub> = 50Ω, C <sub>VCC</sub> = 50pF, C <sub>VL</sub> = 15pF, MAX3002-MAX3012			5	
Part-to-Part Skew	t <sub>PPSKEW</sub>	R <sub>S</sub> = 50Ω, C <sub>VCC</sub> = 50pF, C <sub>VL</sub> = 50pF, ΔT <sub>A</sub> = +20°C, MAX3000E (Note 3)			800	ns
		R <sub>S</sub> = 50Ω, C <sub>VCC</sub> = 50pF, C <sub>VL</sub> = 50pF, ΔT <sub>A</sub> = +20°C, MAX3001E (Note 3)			30	
		R <sub>S</sub> = 50Ω, C <sub>VCC</sub> = 50pF, C <sub>VL</sub> = 15pF, ΔT <sub>A</sub> = +20°C, MAX3002-MAX3012 (Note 3)			10	
Propagation Delay from I/O V <sub>L_</sub> to I/O V <sub>CC_</sub> after EN	t <sub>EN-VCC</sub>	C <sub>VCC</sub> = 50pF, MAX3000E/MAX3001E, MAX3002-MAX3012, Figure 3				µs
Propagation Delay from I/O V <sub>CC_</sub> to I/O V <sub>L_</sub> after EN	t <sub>EN-VL</sub>	C <sub>VL</sub> = 50pF, MAX3000E/MAX3001E/MAX3002/MAX3004-MAX3012, Figure 4			2	µs
		C <sub>VL</sub> = 15pF, MAX3003, Figure 4			2	
Maximum Data Rate		R <sub>S</sub> = 50Ω, C <sub>VCC</sub> = 50pF, C <sub>VL</sub> = 50pF, MAX3000E	230			kbps
		R <sub>S</sub> = 50Ω, C <sub>VCC</sub> = 50pF, C <sub>VL</sub> = 50pF, MAX3001E	4			Mbps
		R <sub>S</sub> = 50Ω, C <sub>VCC</sub> = 50pF, C <sub>VL</sub> = 15pF, MAX3002-MAX3012	20			

**Note 3:** V<sub>CC</sub> from device 1 must equal V<sub>CC</sub> of device 2; V<sub>L</sub> from device 1 must equal V<sub>L</sub> of device 2.

# +1.2V to +5.5V, ±15kV ESD-Protected, 0.1µA, 35Mbps, 8-Channel Level Translators

## TIMING CHARACTERISTICS—MAX3002–MAX3012

( $V_{CC} = +1.65V$  to  $+5.5V$ ,  $V_L = +1.2V$  to  $V_{CC}$ ,  $EN = V_L$  (MAX3002/MAX3004–MAX3012),  $EN\ A/B = V_L$  or 0 (MAX3003),  $T_A = T_{MIN}$  to  $T_{MAX}$ .) (Notes 1, 2)

PARAMETER	SYMBOL	CONDITIONS	MIN	TYP	MAX	UNITS
<b>+1.2V ≤ V<sub>L</sub> ≤ V<sub>CC</sub> ≤ +3.3V</b>						
I/O V <sub>CC</sub> _ Rise Time	t <sub>RVCC</sub>				15	ns
I/O V <sub>CC</sub> _ Fall Time	t <sub>FVCC</sub>				15	ns
I/O V <sub>L</sub> _ Rise Time	t <sub>RVL</sub>				15	ns
I/O V <sub>L</sub> _ Fall Time	t <sub>FVL</sub>				15	ns
Propagation Delay	I/O <sub>VL</sub> -V <sub>CC</sub>	Driving I/O V <sub>L</sub> _			15	ns
	I/O <sub>VCC</sub> -V <sub>L</sub>	Driving I/O V <sub>CC</sub> _			15	
Channel-to-Channel Skew	t <sub>SKEW</sub>	Each translator equally loaded			5	ns
Maximum Data Rate			20			Mbps
<b>+2.5V ≤ V<sub>L</sub> ≤ V<sub>CC</sub> ≤ +3.3V</b>						
I/O V <sub>CC</sub> _ Rise Time	t <sub>RVCC</sub>				8.5	ns
I/O V <sub>CC</sub> _ Fall Time	t <sub>FVCC</sub>				8.5	ns
I/O V <sub>L</sub> _ Rise Time	t <sub>RVL</sub>				8.5	ns
I/O V <sub>L</sub> _ Fall Time	t <sub>FVL</sub>				8.5	ns
Propagation Delay	I/O <sub>VL</sub> -V <sub>CC</sub>	Driving I/O V <sub>L</sub> _			8.5	ns
	I/O <sub>VCC</sub> -V <sub>L</sub>	Driving I/O V <sub>CC</sub> _			8.5	
Channel-to-Channel Skew	t <sub>SKEW</sub>	Each translator equally loaded			10	ns
Maximum Data Rate			35			Mbps
<b>+1.8V ≤ V<sub>L</sub> ≤ V<sub>CC</sub> ≤ +2.5V</b>						
I/O V <sub>CC</sub> _ Rise Time	t <sub>RVCC</sub>				10	ns
I/O V <sub>CC</sub> _ Fall Time	t <sub>FVCC</sub>				10	ns
I/O V <sub>L</sub> _ Rise Time	t <sub>RVL</sub>				10	ns
I/O V <sub>L</sub> _ Fall Time	t <sub>FVL</sub>				10	ns
Propagation Delay	I/O <sub>VL</sub> -V <sub>CC</sub>	Driving I/O V <sub>L</sub> _			15	ns
	I/O <sub>VCC</sub> -V <sub>L</sub>	Driving I/O V <sub>CC</sub> _			10	
Channel-to-Channel Skew	t <sub>SKEW</sub>	Each translator equally loaded			5	ns
Maximum Data Rate			30			Mbps

# +1.2V to +5.5V, ±15kV ESD-Protected, 0.1μA, 35Mbps, 8-Channel Level Translators

## Typical Operating Characteristics

( $T_A = +25^\circ\text{C}$ , unless otherwise noted.)

**$V_L$  SUPPLY CURRENT vs. SUPPLY VOLTAGE**  
(DRIVING I/O  $V_L$ ,  $V_L = 1.8\text{V}$ )

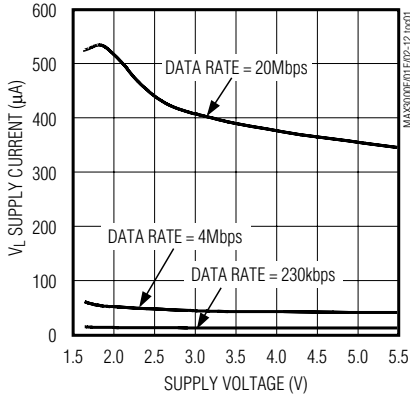

**$V_{CC}$  SUPPLY CURRENT vs. SUPPLY VOLTAGE**  
(DRIVING I/O  $V_L$ ,  $V_L = 1.8\text{V}$ )

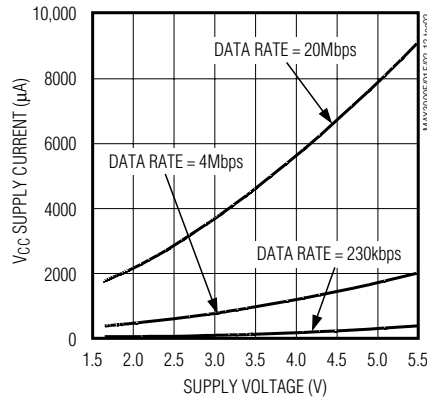

**$V_L$  SUPPLY CURRENT vs. TEMPERATURE**  
(DRIVING I/O  $V_{CC}$ ,  $V_{CC} = 3.3\text{V}$ ,  $V_L = 1.8\text{V}$ )

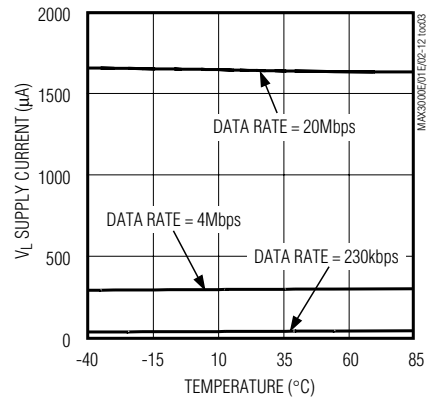

**$V_{CC}$  SUPPLY CURRENT vs. TEMPERATURE**  
(DRIVING I/O  $V_{CC}$ ,  $V_{CC} = 3.3\text{V}$ ,  $V_L = 1.8\text{V}$ )

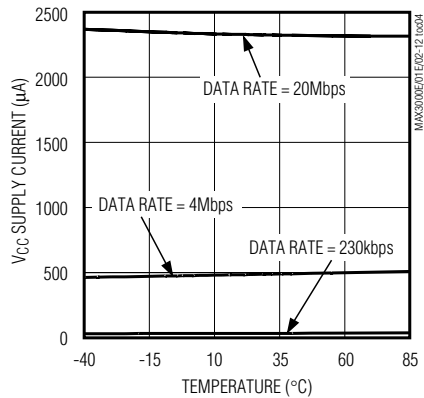

**$V_L$  SUPPLY CURRENT vs. CAPACITIVE LOAD ON I/O  $V_{CC}$**   
(DRIVING I/O  $V_L$ ,  $V_{CC} = 3.3\text{V}$ ,  $V_L = 1.8\text{V}$ )

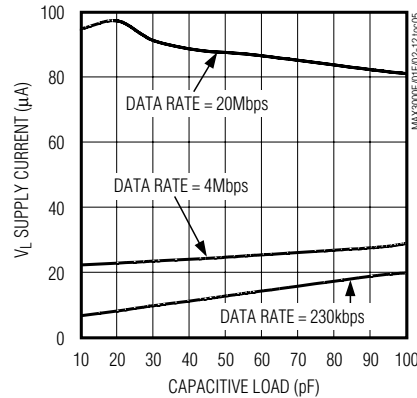

**$V_{CC}$  SUPPLY CURRENT vs. CAPACITIVE LOAD ON I/O  $V_{CC}$**   
(DRIVING I/O  $V_L$ ,  $V_{CC} = 3.3\text{V}$ ,  $V_L = 1.8\text{V}$ )

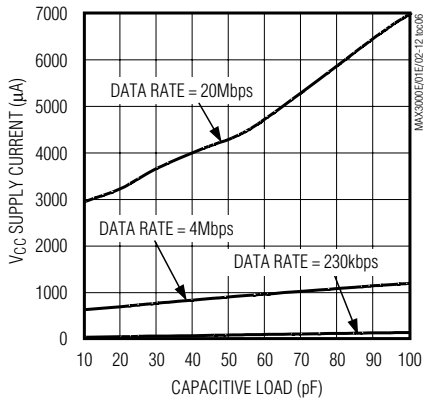

**MAX3000E**  
**RISE/FALL TIME vs. CAPACITIVE LOAD ON I/O  $V_{CC}$**   
(DRIVING I/O  $V_L$ ,  $V_{CC} = 3.3\text{V}$ ,  $V_L = 1.8\text{V}$ )

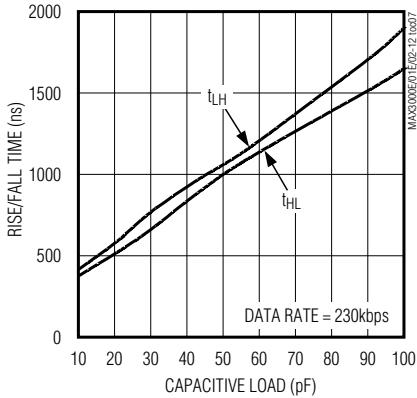

# +1.2V to +5.5V, ±15kV ESD-Protected, 0.1µA, 35Mbps, 8-Channel Level Translators

## Typical Operating Characteristics (continued)

(T<sub>A</sub> = +25°C, unless otherwise noted.)

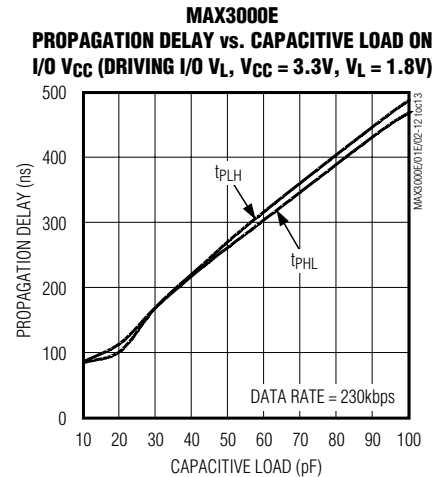
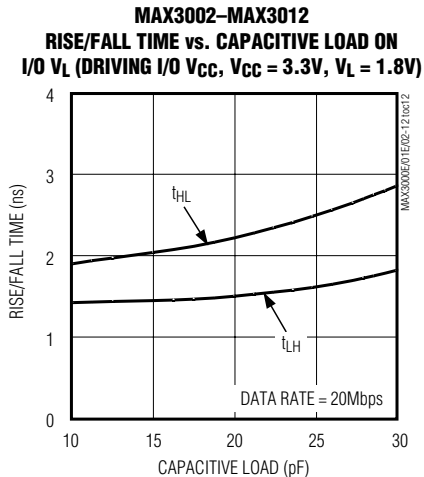
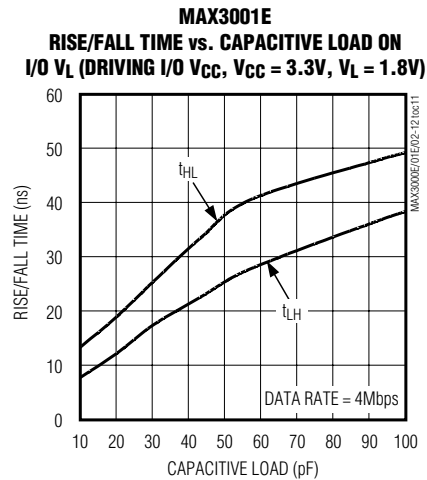
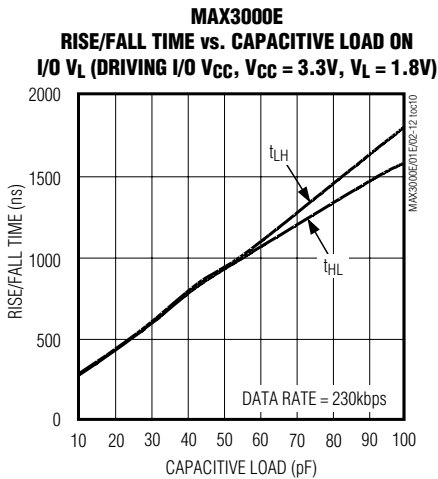
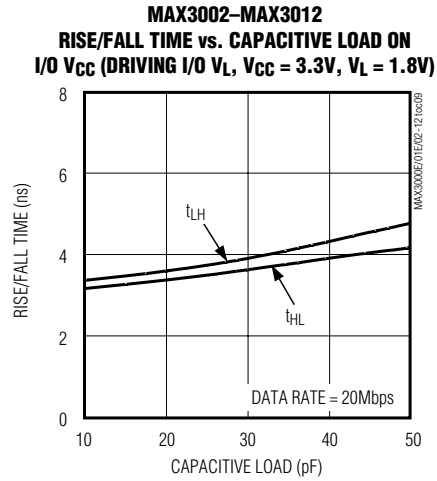
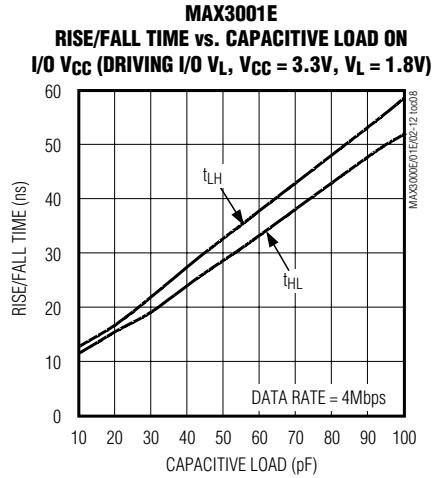

# +1.2V to +5.5V, ±15kV ESD-Protected, 0.1μA, 35Mbps, 8-Channel Level Translators

## Typical Operating Characteristics (continued)

(T<sub>A</sub> = +25°C, unless otherwise noted.)

**MAX3001E**  
PROPAGATION DELAY vs. CAPACITIVE LOAD ON I/O V<sub>CC</sub> (DRIVING I/O V<sub>L</sub>, V<sub>CC</sub> = 3.3V, V<sub>L</sub> = 1.8V)

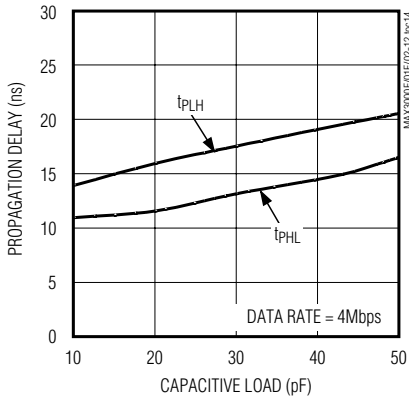

**MAX3002-MAX3012**  
PROPAGATION DELAY vs. CAPACITIVE LOAD ON I/O V<sub>CC</sub> (DRIVING I/O V<sub>L</sub>, V<sub>CC</sub> = 3.3V, V<sub>L</sub> = 1.8V)

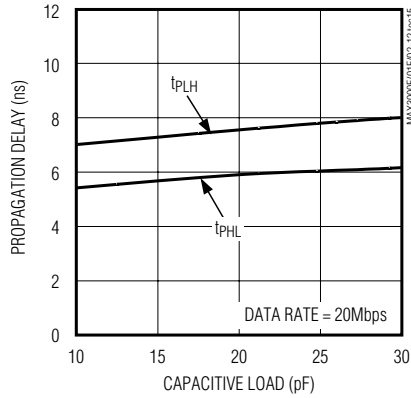

**MAX3000E**  
PROPAGATION DELAY vs. CAPACITIVE LOAD ON I/O V<sub>L</sub> (DRIVING I/O V<sub>CC</sub>, V<sub>CC</sub> = 3.3V, V<sub>L</sub> = 1.8V)

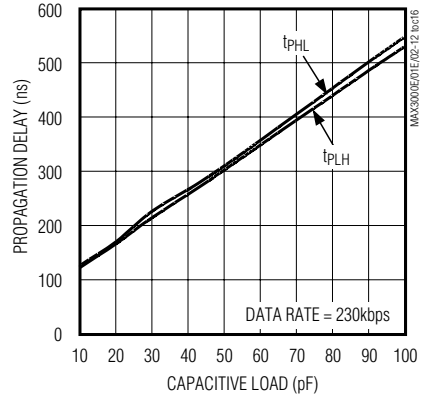

**MAX3001E**  
PROPAGATION DELAY vs. CAPACITIVE LOAD ON I/O V<sub>L</sub> (DRIVING I/O V<sub>CC</sub>, V<sub>CC</sub> = 3.3V, V<sub>L</sub> = 1.8V)

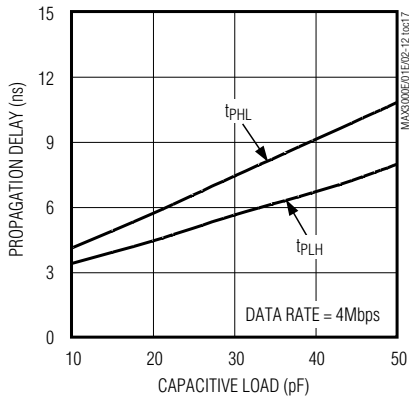

**MAX3002-MAX3012**  
PROPAGATION DELAY vs. CAPACITIVE LOAD ON I/O V<sub>L</sub> (DRIVING I/O V<sub>CC</sub>, V<sub>CC</sub> = 3.3V, V<sub>L</sub> = 1.8V)

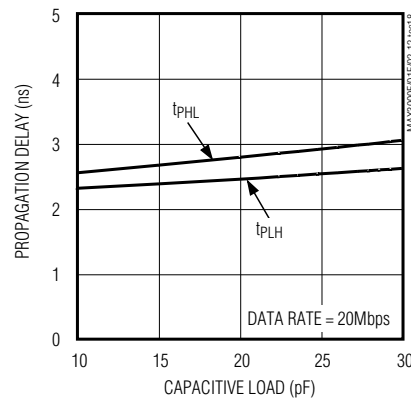

**MAX3000E RAIL-TO-RAIL DRIVING**  
(DRIVING I/O V<sub>L</sub>, V<sub>CC</sub> = 3.3V, V<sub>L</sub> = 1.8V, C<sub>VCC</sub> = 50pF, DATA RATE = 230kbps)

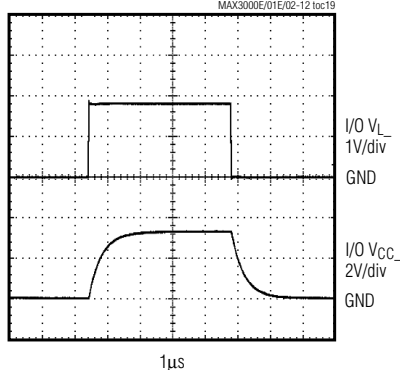

**MAX3001E RAIL-TO-RAIL DRIVING**  
(DRIVING I/O V<sub>L</sub>, V<sub>CC</sub> = 3.3V, V<sub>L</sub> = 1.8V, C<sub>VCC</sub> = 50pF, DATA RATE = 4Mbps)

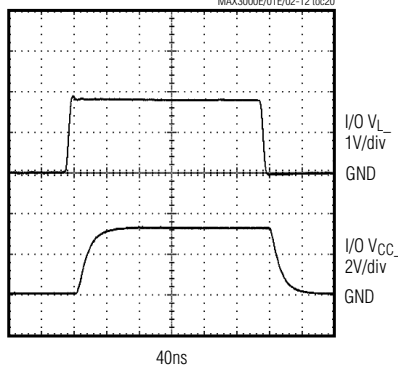

**MAX3002-MAX3012 RAIL-TO-RAIL DRIVING**  
(DRIVING I/O V<sub>L</sub>, V<sub>CC</sub> = 3.3V, V<sub>L</sub> = 1.8V, C<sub>VCC</sub> = 50pF, DATA RATE = 20Mbps)

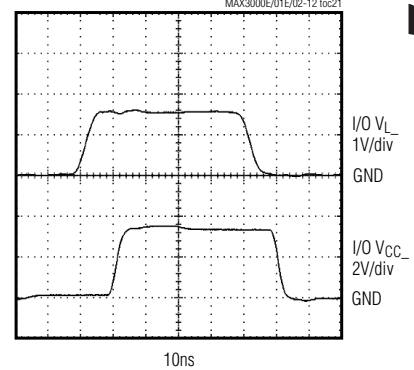

MAX3000E/MAX3001E/MAX3002-MAX3012

# +1.2V to +5.5V, ±15kV ESD-Protected, 0.1µA, 35Mbps, 8-Channel Level Translators

## Pin Description

### MAX3000E/MAX3001E/MAX3002

PIN		NAME	FUNCTION
TSSOP	UCSP		
1	B1	I/O V <sub>L1</sub>	Input/Output 1, Referenced to V <sub>L</sub>
2	A1	V <sub>L</sub>	Logic Input Voltage, +1.2V ≤ V <sub>L</sub> ≤ V <sub>CC</sub> . Bypass V <sub>L</sub> to GND with a 0.1µF capacitor.
3	A2	I/O V <sub>L2</sub>	Input/Output 2, Referenced to V <sub>L</sub>
4	B2	I/O V <sub>L3</sub>	Input/Output 3, Referenced to V <sub>L</sub>
5	A3	I/O V <sub>L4</sub>	Input/Output 4, Referenced to V <sub>L</sub>
6	B3	I/O V <sub>L5</sub>	Input/Output 5, Referenced to V <sub>L</sub>
7	A4	I/O V <sub>L6</sub>	Input/Output 6, Referenced to V <sub>L</sub>
8	B4	I/O V <sub>L7</sub>	Input/Output 7, Referenced to V <sub>L</sub>
9	A5	I/O V <sub>L8</sub>	Input/Output 8, Referenced to V <sub>L</sub>
10	B5	EN	Enable Input. If EN is pulled low, I/O V <sub>CC1</sub> to I/O V <sub>CC8</sub> are in three-state, while I/O V <sub>L1</sub> to I/O V <sub>L8</sub> have internal 6kΩ pulldown resistors. Drive EN high (V <sub>L</sub> ) for normal operation.
11	C5	GND	Ground
12	D5	I/O V <sub>CC8</sub>	Input/Output 8, Referenced to V <sub>CC</sub>
13	C4	I/O V <sub>CC7</sub>	Input/Output 7, Referenced to V <sub>CC</sub>
14	D4	I/O V <sub>CC6</sub>	Input/Output 6, Referenced to V <sub>CC</sub>
15	C3	I/O V <sub>CC5</sub>	Input/Output 5, Referenced to V <sub>CC</sub>
16	D3	I/O V <sub>CC4</sub>	Input/Output 4, Referenced to V <sub>CC</sub>
17	C2	I/O V <sub>CC3</sub>	Input/Output 3, Referenced to V <sub>CC</sub>
18	D2	I/O V <sub>CC2</sub>	Input/Output 2, Referenced to V <sub>CC</sub>
19	D1	V <sub>CC</sub>	V <sub>CC</sub> Input Voltage, +1.65V ≤ V <sub>CC</sub> ≤ +5.5V. Bypass V <sub>CC</sub> to GND with a 0.1µF capacitor.
20	C1	I/O V <sub>CC1</sub>	Input/Output 1, Referenced to V <sub>CC</sub>

# +1.2V to +5.5V, ±15kV ESD-Protected, 0.1µA, 35Mbps, 8-Channel Level Translators

## Pin Description (continued)

### MAX3003

PIN		NAME	FUNCTION
TSSOP	UCSP		
1	B1	I/O V <sub>L</sub> 1A	Input/Output 1A, Referenced to V <sub>L</sub>
2	A1	V <sub>L</sub>	Logic Input Voltage, +1.2V ≤ V <sub>L</sub> ≤ V <sub>CC</sub> . Bypass V <sub>L</sub> to GND with a 0.1µF capacitor.
3	A2	I/O V <sub>L</sub> 2A	Input/Output 2A, Referenced to V <sub>L</sub>
4	B2	I/O V <sub>L</sub> 3A	Input/Output 3A, Referenced to V <sub>L</sub>
5	A3	I/O V <sub>L</sub> 4A	Input/Output 4A, Referenced to V <sub>L</sub>
6	B3	I/O V <sub>L</sub> 1B	Input/Output 1B, Referenced to V <sub>L</sub>
7	A4	I/O V <sub>L</sub> 2B	Input/Output 2B, Referenced to V <sub>L</sub>
8	B4	I/O V <sub>L</sub> 3B	Input/Output 3B, Referenced to V <sub>L</sub>
9	A5	I/O V <sub>L</sub> 4B	Input/Output 4B, Referenced to V <sub>L</sub>
10	B5	EN A/B	Enable Input. If EN A/B is pulled low, channels 1B through 4B are active, and channels 1A through 4A are in three-state. If EN A/B is driven high to V <sub>L</sub> , channels 1A through 4A are active, and channels 1B through 4B are in three-state.
11	C5	GND	Ground
12	D5	I/O V <sub>CC</sub> 4B	Input/Output 4B, Referenced to V <sub>CC</sub>
13	C4	I/O V <sub>CC</sub> 3B	Input/Output 3B, Referenced to V <sub>CC</sub>
14	D4	I/O V <sub>CC</sub> 2B	Input/Output 2B, Referenced to V <sub>CC</sub>
15	C3	I/O V <sub>CC</sub> 1B	Input/Output 1B, Referenced to V <sub>CC</sub>
16	D3	I/O V <sub>CC</sub> 4A	Input/Output 4A, Referenced to V <sub>CC</sub>
17	C2	I/O V <sub>CC</sub> 3A	Input/Output 3A, Referenced to V <sub>CC</sub>
18	D2	I/O V <sub>CC</sub> 2A	Input/Output 2A, Referenced to V <sub>CC</sub>
19	D1	V <sub>CC</sub>	V <sub>CC</sub> Input Voltage, +1.65V ≤ V <sub>CC</sub> ≤ +5.5V. Bypass V <sub>CC</sub> to GND with a 0.1µF capacitor.
20	C1	I/O V <sub>CC</sub> 1A	Input/Output 1A, Referenced to V <sub>CC</sub>

MAX3000E/MAX3001E/MAX3002-MAX3012

# +1.2V to +5.5V, ±15kV ESD-Protected, 0.1µA, 35Mbps, 8-Channel Level Translators

## Pin Description (continued)

### MAX3004–MAX3012

NAME	FUNCTION (Note 1)
V <sub>CC</sub>	V <sub>CC</sub> Input Voltage, +1.65V < V <sub>CC</sub> < +5.5V. Bypass V <sub>CC</sub> to GND with a 0.1µF capacitor.
V <sub>L</sub>	Logic Input Voltage, +1.2V ≤ V <sub>L</sub> ≤ V <sub>CC</sub> . Bypass V <sub>L</sub> to GND with a 0.1µF capacitor.
GND	Ground
EN (MAX3004)	Enable Input. If EN is pulled low, OV <sub>CC</sub> 1–OV <sub>CC</sub> 8 are in three-state, while IV <sub>L</sub> 1–IV <sub>L</sub> 8 have 6kΩ pulldown resistors. Drive EN high (V <sub>L</sub> ) for normal operation.
EN (MAX3005)	Enable Input. If EN is pulled low, IV <sub>CC</sub> 1 and OV <sub>CC</sub> 2–OV <sub>CC</sub> 8 are in three-state, while OV <sub>L</sub> 1 and IV <sub>L</sub> 2–IV <sub>L</sub> 8 have 6kΩ pulldown resistors. Drive EN high (V <sub>L</sub> ) for normal operation.
EN (MAX3006)	Enable Input. If EN is pulled low, IV <sub>CC</sub> 1, IV <sub>CC</sub> 2, and OV <sub>CC</sub> 3–OV <sub>CC</sub> 8 are in three-state, while OV <sub>L</sub> 1, OV <sub>L</sub> 2, and IV <sub>L</sub> 3–IV <sub>L</sub> 8 have 6kΩ pulldown resistors. Drive EN high (V <sub>L</sub> ) for normal operation.
EN (MAX3007)	Enable Input. If EN is pulled low, IV <sub>CC</sub> 1, IV <sub>CC</sub> 2, IV <sub>CC</sub> 3, and OV <sub>CC</sub> 4–OV <sub>CC</sub> 8 are in three-state, while OV <sub>L</sub> 1, OV <sub>L</sub> 2, OV <sub>L</sub> 3, and IV <sub>L</sub> 4–IV <sub>L</sub> 8 have 6kΩ pulldown resistors. Drive EN high (V <sub>L</sub> ) for normal operation.
EN (MAX3008)	Enable Input. If EN is pulled low, IV <sub>CC</sub> 1–IV <sub>CC</sub> 4 and OV <sub>CC</sub> 5–OV <sub>CC</sub> 8 are in three-state, while OV <sub>L</sub> 1–OV <sub>L</sub> 4 and IV <sub>L</sub> 5–IV <sub>L</sub> 8 have 6kΩ pulldown resistors. Drive EN high (V <sub>L</sub> ) for normal operation.
EN (MAX3009)	Enable Input. If EN is pulled low, IV <sub>CC</sub> 1–IV <sub>CC</sub> 5, OV <sub>CC</sub> 6, OV <sub>CC</sub> 7, and OV <sub>CC</sub> 8 are in three-state, while OV <sub>L</sub> 1–OV <sub>L</sub> 5, IV <sub>L</sub> 6, IV <sub>L</sub> 7, and IV <sub>L</sub> 8 have 6kΩ pulldown resistors. Drive EN high (V <sub>L</sub> ) for normal operation.
EN (MAX3010)	Enable Input. If EN is pulled low, IV <sub>CC</sub> 1–IV <sub>CC</sub> 6, OV <sub>CC</sub> 7, and OV <sub>CC</sub> 8 are in three-state, while OV <sub>L</sub> 1–OV <sub>L</sub> 6, IV <sub>L</sub> 7, and IV <sub>L</sub> 8 have 6kΩ pulldown resistors. Drive EN high (V <sub>L</sub> ) for normal operation.
EN (MAX3011)	Enable Input. If EN is pulled low, IV <sub>CC</sub> 1–IV <sub>CC</sub> 7 and OV <sub>CC</sub> 8 are in three-state, while OV <sub>L</sub> 1–OV <sub>L</sub> 7 and IV <sub>L</sub> 8 have 6kΩ pulldown resistors. Drive EN high (V <sub>L</sub> ) for normal operation.
EN (MAX3012)	Enable Input. If EN is pulled low, IV <sub>CC</sub> 1–IV <sub>CC</sub> 8 are in three-state, while OV <sub>L</sub> 1–OV <sub>L</sub> 8 have 6kΩ pulldown resistors. Drive EN high (V <sub>L</sub> ) for normal operation.
IV <sub>L</sub> 1–IV <sub>L</sub> 8	Inputs Referenced to V <sub>L</sub> , Numbers 1 to 8
OV <sub>L</sub> 1–OV <sub>L</sub> 8	Outputs Referenced to V <sub>L</sub> , Numbers 1 to 8
IV <sub>CC</sub> 1–IV <sub>CC</sub> 8	Inputs Referenced to V <sub>CC</sub> , Numbers 1 to 8
OV <sub>CC</sub> 1–OV <sub>CC</sub> 8	Outputs Referenced to V <sub>CC</sub> , Numbers 1 to 8

**Note 1:** For specific pin numbers, see the *Pin Configurations*.

# +1.2V to +5.5V, ±15kV ESD-Protected, 0.1µA, 35Mbps, 8-Channel Level Translators

## Test Circuits/Timing Diagrams

MAX3000E/MAX3001E/MAX3002-MAX3012

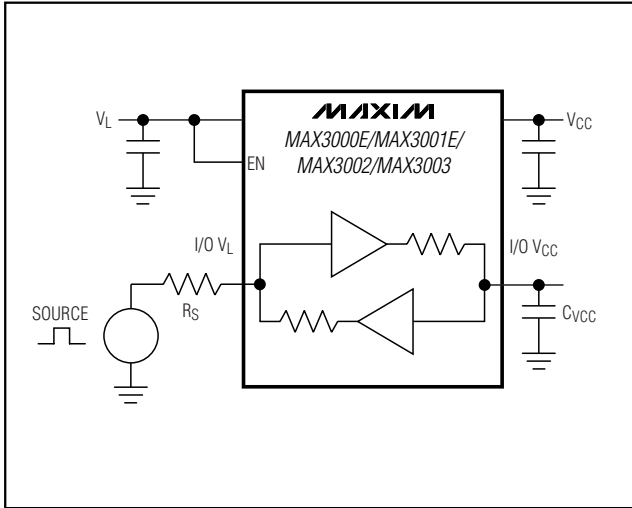

Figure 1a. Driving I/O VL

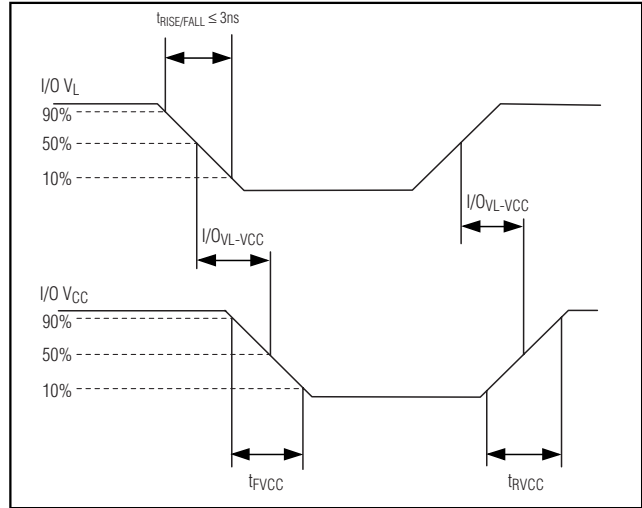

Figure 1b. Timing for Driving I/O VL

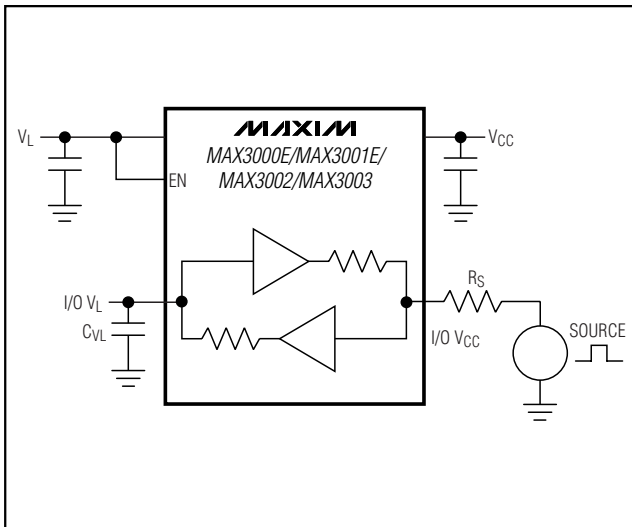

Figure 2a. Driving I/O VCC

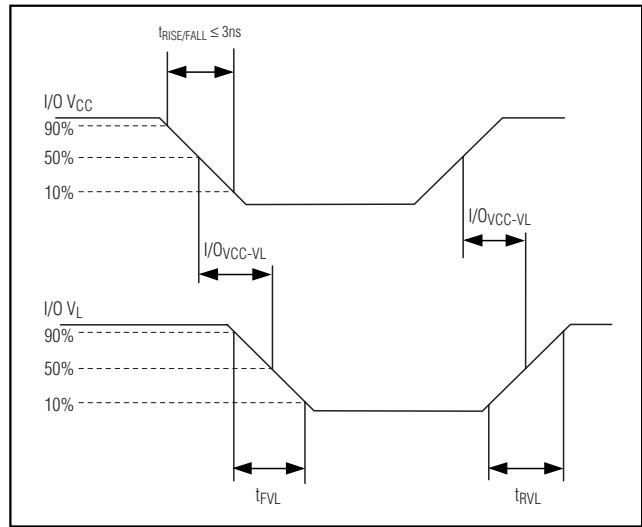

Figure 2b. Timing for Driving I/O VCC

# +1.2V to +5.5V, ±15kV ESD-Protected, 0.1µA, 35Mbps, 8-Channel Level Translators

## Test Circuits/Timing Diagrams (continued)

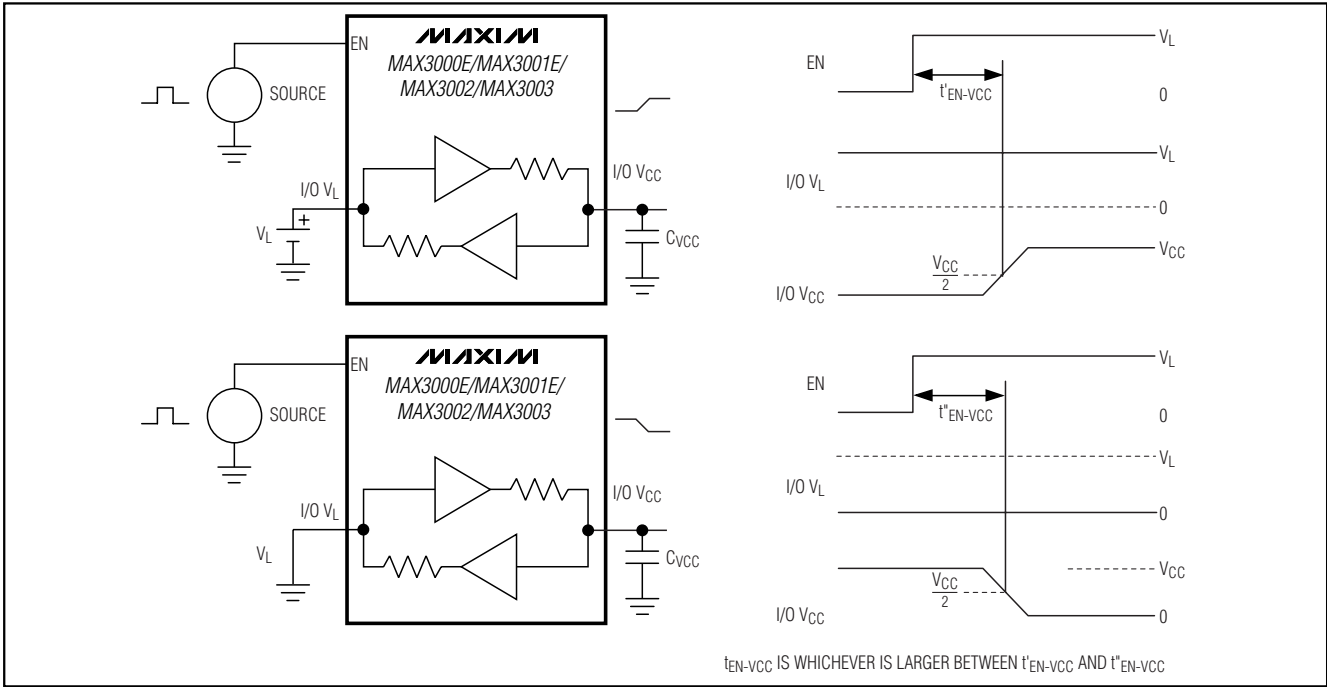

Figure 3. Propagation Delay from I/O  $V_L$  to I/O  $V_{CC}$  After EN

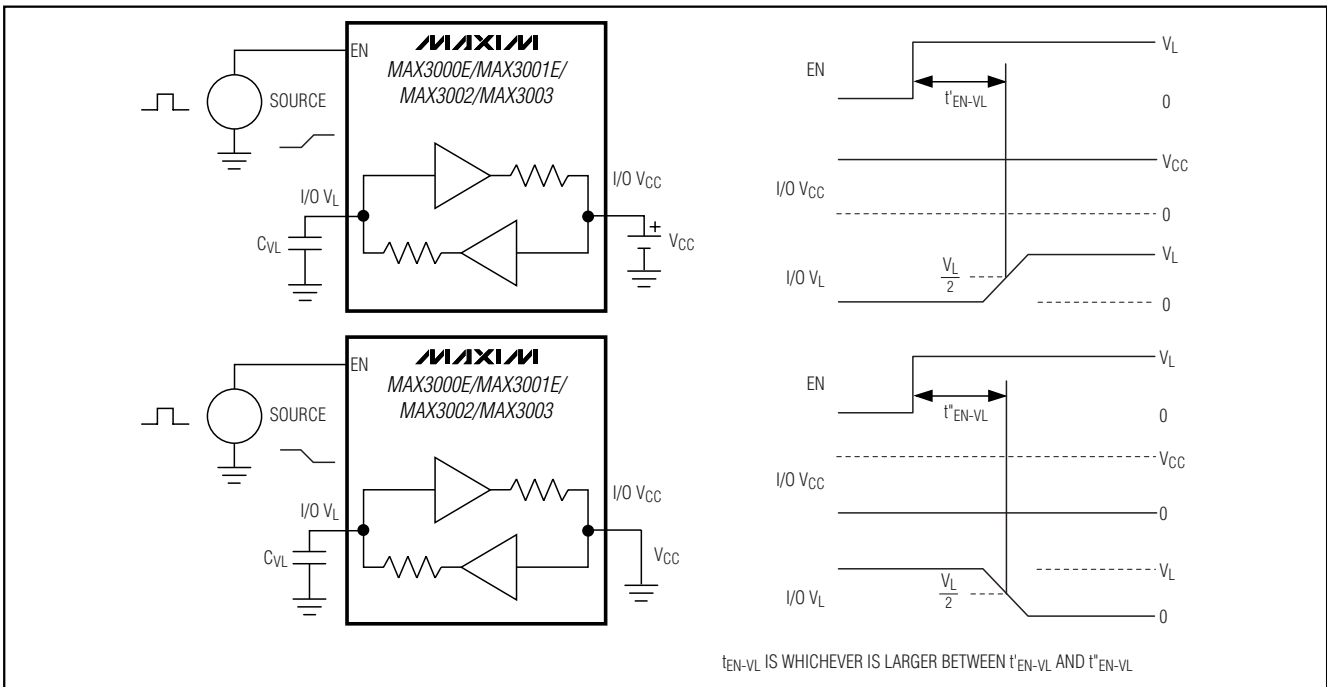

Figure 4. Propagation Delay from I/O  $V_{CC}$  to I/O  $V_L$  After EN

# +1.2V to +5.5V, ±15kV ESD-Protected, 0.1µA, 35Mbps, 8-Channel Level Translators

## Detailed Description

The MAX3000E/MAX3001E/MAX3002–MAX3012 logic-level translators provide the level shifting necessary to allow data transfer in a multivoltage system. Externally applied voltages,  $V_{CC}$  and  $V_L$ , set the logic levels on either side of the device. Logic signals present on the  $V_L$  side of the device appear as a higher voltage logic signal on the  $V_{CC}$  side of the device, and vice-versa. The MAX3000E/MAX3001E/MAX3002/MAX3003 are bidirectional level translators allowing data translation in either direction ( $V_L \leftrightarrow V_{CC}$ ) on any single data line. The MAX3004–MAX3012 unidirectional level translators level shift data in one direction ( $V_L \rightarrow V_{CC}$  or  $V_{CC} \rightarrow V_L$ ) on any single data line. The MAX3000E/MAX3001E/MAX3002–MAX3012 accept  $V_L$  from +1.2V to +5.5V. All devices have  $V_{CC}$  ranging from +1.65V to +5.5V, making them ideal for data transfer between low-voltage ASICs/PLDs and higher voltage systems.

The MAX3000E/MAX3001E/MAX3002/MAX3004–MAX3012 feature an output enable mode that reduces  $V_{CC}$  supply current to less than 2µA, and  $V_L$  supply current to less than 2µA when in shutdown. The MAX3000E/MAX3001E have ±15kV ESD protection on the  $V_{CC}$  side for greater protection in applications that route signals externally. The MAX3000E operates at a guaranteed data rate of 230kbps; the MAX3001E operates at a guaranteed data rate of 4Mbps and the MAX3002–MAX3012 are guaranteed with a data rate of 20Mbps of operation over the entire specified operating voltage range.

### Level Translation

For proper operation, ensure that  $+1.65V \leq V_{CC} \leq +5.5V$ ,  $+1.2V \leq V_L \leq +5.5V$ , and  $V_L \leq V_{CC}$ . During power-up sequencing,  $V_L \geq V_{CC}$  does not damage the device. During power-supply sequencing, when  $V_{CC}$  is floating and  $V_L$  is powering up, up to 10mA current can be sourced to each load on the  $V_L$  side, yet the device does not latch up.

The maximum data rate also depends heavily on the load capacitance (see the *Typical Operating Characteristics*), output impedance of the driver, and the operational voltage range (see the *Timing Characteristics*).

### Input Driver Requirements

The MAX3001E/MAX3002–MAX3012 architecture is based on a one-shot accelerator output stage. See Figure 5. Accelerator output stages are always in three-state except when there is a transition on any of the translators on the input side, either I/O  $V_L$  or I/O  $V_{CC}$ .

Then, a short pulse is generated during which the accelerator output stages become active and charge/discharge the capacitances at the I/Os. Due to its bidirectional nature, both input stages become active during the one-shot pulse. This can lead to some current feeding into the external source that is driving the translator. However, this behavior helps to speed up the transition on the driven side.

For proper operation, the driver has to meet the following conditions: 50Ω maximum output impedance and 20mA minimum output current (for 20Mbps versions), 400Ω maximum output impedance and 4mA minimum output current (for 4Mbps versions), 1kΩ maximum output impedance and 1mA minimum output current (for 230kbps versions). Figure 6 shows a typical input current vs. input voltage.

### Enable Output Mode (EN, EN A/B)

The MAX3000E/MAX3001E/MAX3002 and the MAX3004–MAX3012 feature an EN input, and the MAX3003 has an EN A/B input. Pull EN low to set the MAX3000E/MAX3001E/MAX3002/MAX3004–MAX3012s' I/O  $V_{CC}1$  through I/O  $V_{CC}8$  in three-state output mode, while I/O  $V_L1$  through I/O  $V_L8$  have internal 6kΩ pulldown resistors. Drive EN to logic high ( $V_L$ ) for normal operation. For the MAX3003, pull EN A/B low to place channels 1B through 4B in active mode, while channels 1A through 4A are in three-state mode. Drive EN A/B to logic high ( $V_L$ ) to enable channels 1A through 4A, while channels 1B through 4B remain in three-state mode.

### ±15kV ESD Protection

As with all Maxim devices, ESD-protection structures are incorporated on all pins to protect against electrostatic discharges encountered during handling and assembly. The I/O  $V_{CC}$  lines have extra protection against static discharge. Maxim's engineers have developed state-of-the-art structures to protect these pins against ESD of ±15kV without damage. The ESD structures withstand high ESD in all states: normal operation, three-state output mode, and powered down. After an ESD event, Maxim's E versions keep working without latchup, whereas competing products can latch and must be powered down to remove latchup.

ESD protection can be tested in various ways. The I/O  $V_{CC}$  lines of the MAX3000E/MAX3001E are characterized for protection to ±15kV using the Human Body Model.

# +1.2V to +5.5V, ±15kV ESD-Protected, 0.1µA, 35Mbps, 8-Channel Level Translators

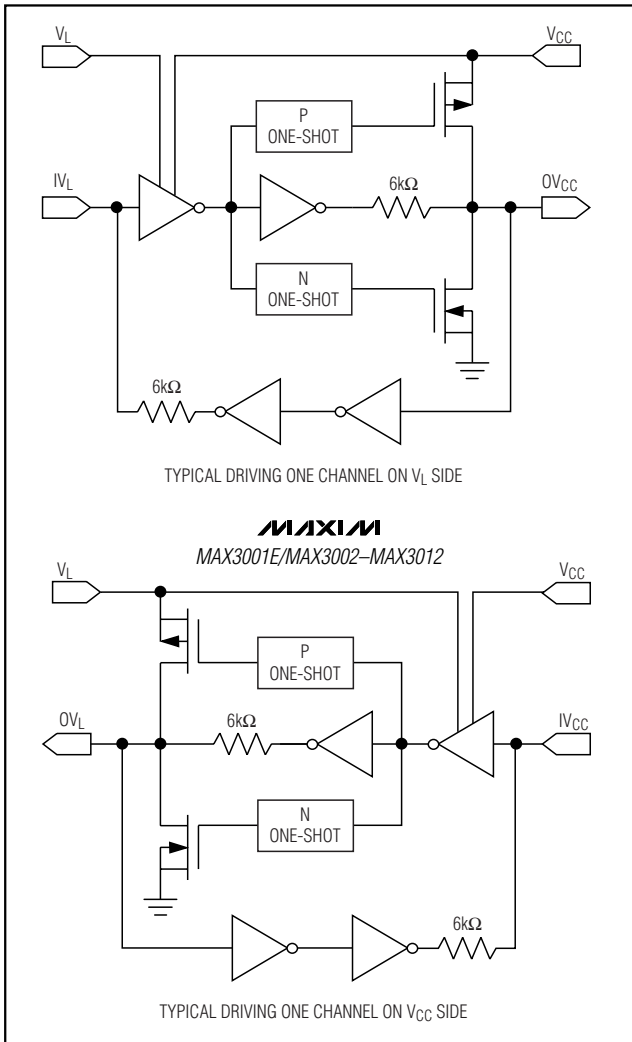

Figure 5. MAX3001E/MAX3002-MAX3012 Simplified Functional Diagram (1 I/O Line)

### ESD Test Conditions

ESD performance depends on a variety of conditions. Contact Maxim for a reliability report that documents test setup, test methodology, and test results.

### Human Body Model

Figure 7a shows the Human Body Model and Figure 7b shows the current waveform it generates when discharged into a low impedance. This model consists of a 100pF capacitor charged to the ESD voltage of interest, which is then discharged into the test device through a 1.5kΩ resistor.

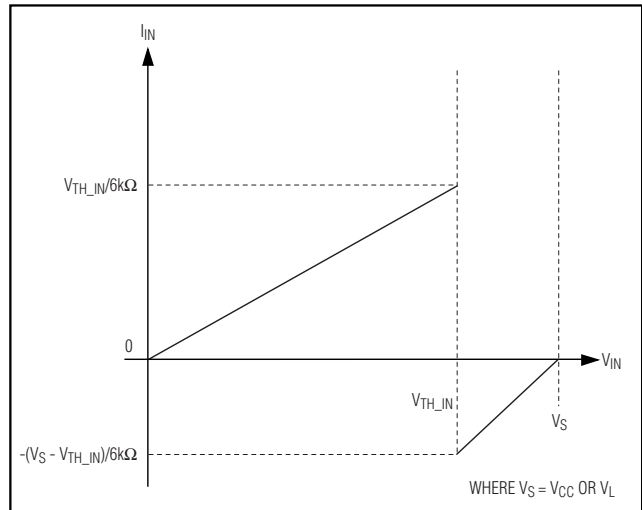

Figure 6. Typical  $I_{IN}$  vs.  $V_{IN}$

### Machine Model

The Machine Model for ESD tests all pins using a 200pF storage capacitor and zero discharge resistance. Its objective is to emulate the stress caused by contact that occurs with handling and assembly during manufacturing. Of course, all pins require this protection during manufacturing, not just inputs and outputs. Therefore, after PC board assembly, the Machine Model is less relevant to I/O ports.

### Applications Information

#### Power-Supply Decoupling

To reduce ripple and the chance of transmitting incorrect data, bypass  $V_L$  and  $V_{CC}$  to ground with a 0.1µF capacitor. To ensure full ±15kV ESD protection, bypass  $V_{CC}$  to ground with a 1µF capacitor. Place all capacitors as close to the power-supply inputs as possible.

#### I<sup>2</sup>C Level Translation

For I<sup>2</sup>C level translation for I<sup>2</sup>C applications, please refer to the MAX3372E-MAX3379E/MAX3390E-MAX3393E datasheet.

#### Unidirectional vs. Bidirectional Level Translator

The MAX3000E/MAX3001E/MAX3002/MAX3003 can also be used to translate signals without inversion. These devices provide the smallest solution (UCSP package) for unidirectional level translation without inversion.

# +1.2V to +5.5V, ±15kV ESD-Protected, 0.1µA, 35Mbps, 8-Channel Level Translators

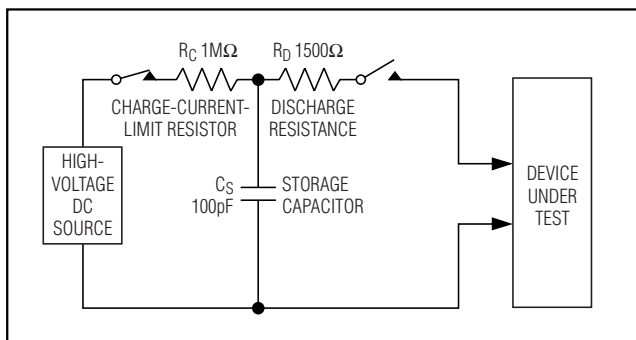

Figure 7a. Human Body ESD Test Model

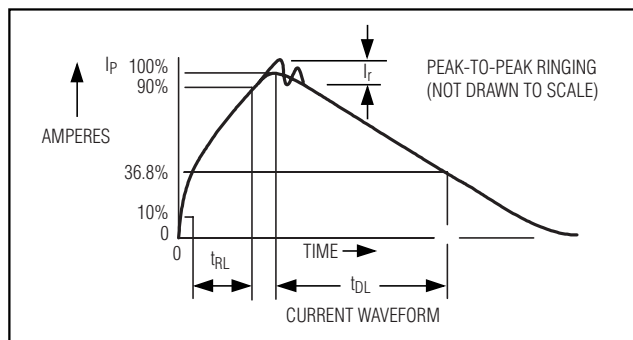

Figure 7b. Human Body Current Waveform

## Selector Guide

PART	EN	EN A/B	Tx/Rx*	DATA RATE	ESD PROTECTION (kV)
MAX3000E	√	—	8/8	230kbps	±15
MAX3001E	√	—	8/8	4Mbps	±15
MAX3002	√	—	8/8	**	±2
MAX3003	—	√	8/8	**	±2
MAX3004	√	—	8/0	**	±2
MAX3005	√	—	7/1	**	±2
MAX3006	√	—	6/2	**	±2
MAX3007	√	—	5/3	**	±2
MAX3008	√	—	4/4	**	±2
MAX3009	√	—	3/5	**	±2
MAX3010	√	—	2/6	**	±2
MAX3011	√	—	1/7	**	±2
MAX3012	√	—	0/8	**	±2

\*Tx = VL → VCC; Rx = VCC → VL

\*\*See Table 1.

Table 1. Data Rate

VL ↔ VCC (V)	MAX3002–MAX3012 GUARANTEED DATA RATE (Mbps)
1.2 ↔ 5.5	40
1.2 ↔ 3.3	20
2.5 ↔ 3.3	35
1.8 ↔ 2.5	30
1.2 ↔ 2.5	20
1.2 ↔ 1.8	20

**+1.2V to +5.5V, ±15kV ESD-Protected, 0.1µA, 35Mbps, 8-Channel Level Translators**

**MAX3000E/MAX3001E/MAX3002 Functional Diagram**

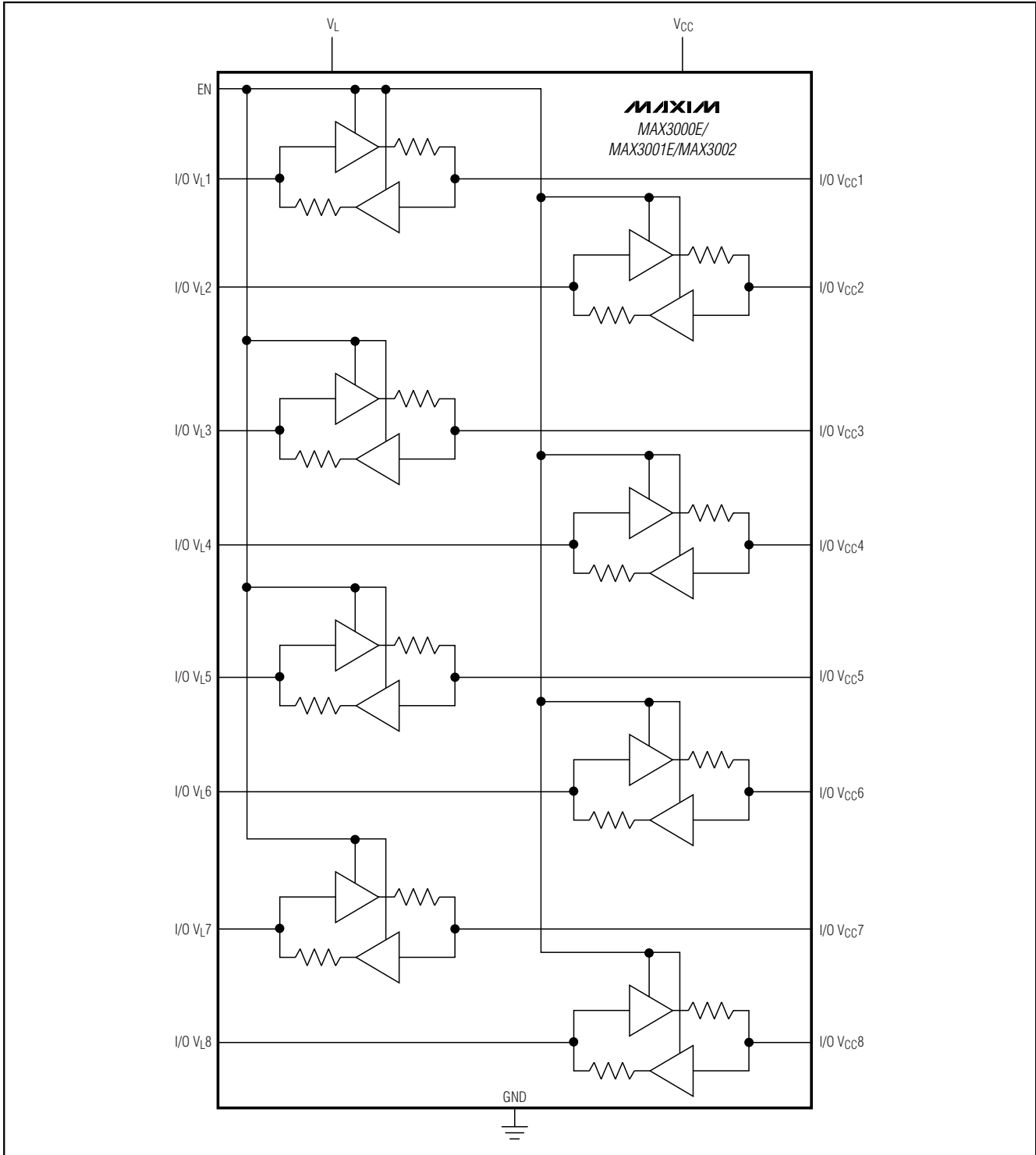

**+1.2V to +5.5V, ±15kV ESD-Protected, 0.1µA,  
35Mbps, 8-Channel Level Translators**

**MAX3003 Functional Diagram**

**MAX3000E/MAX3001E/MAX3002-MAX3012**

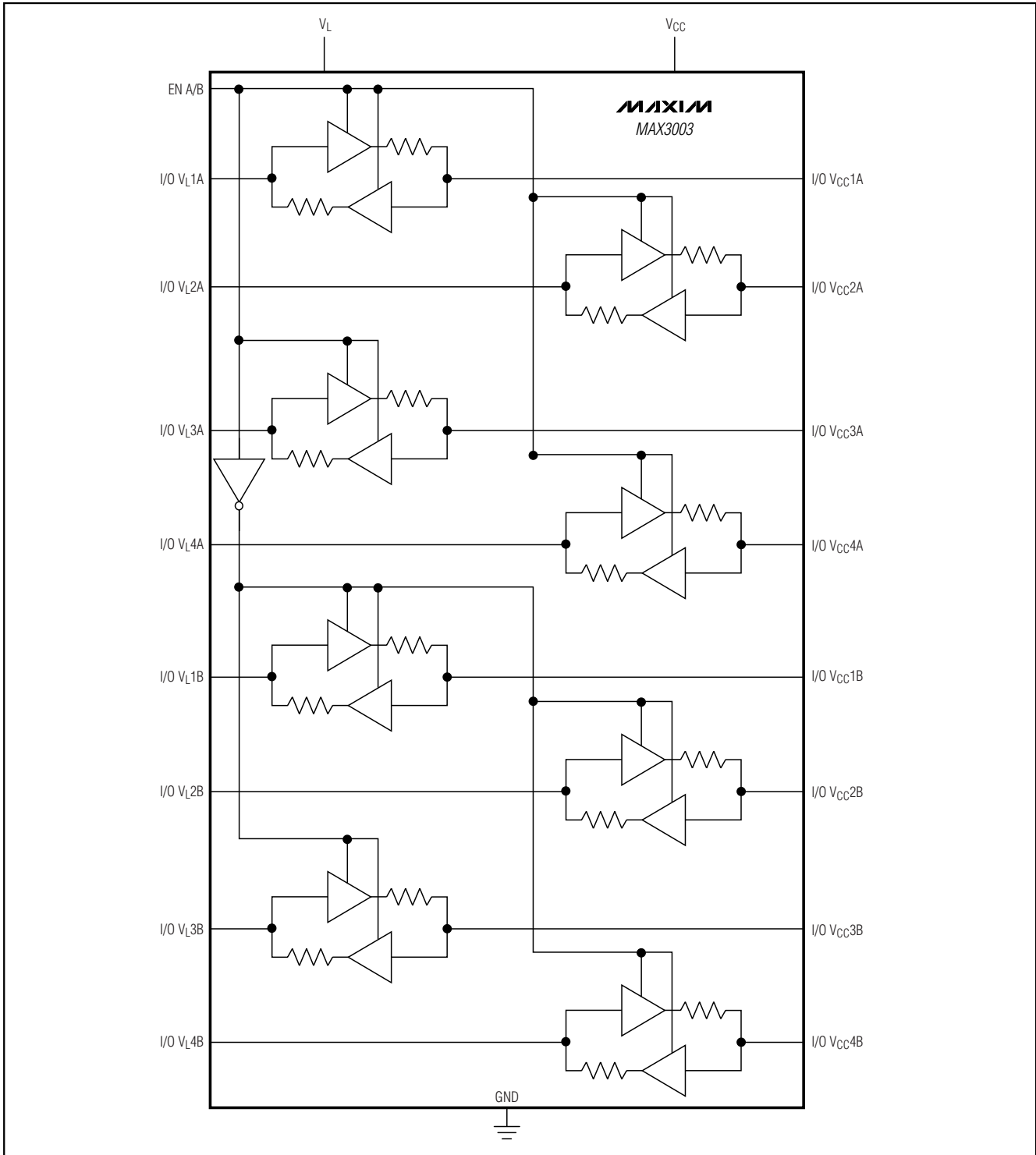

# **+1.2V to +5.5V, ±15kV ESD-Protected, 0.1µA, 35Mbps, 8-Channel Level Translators**

## **Pin Configurations**

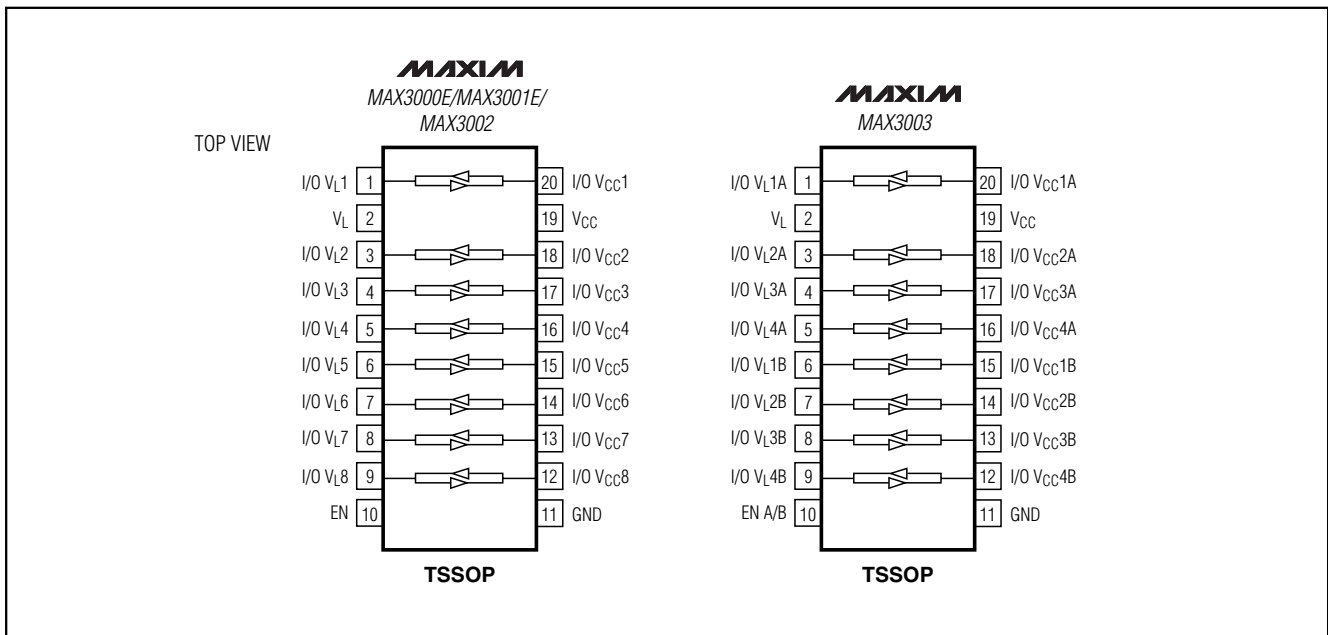
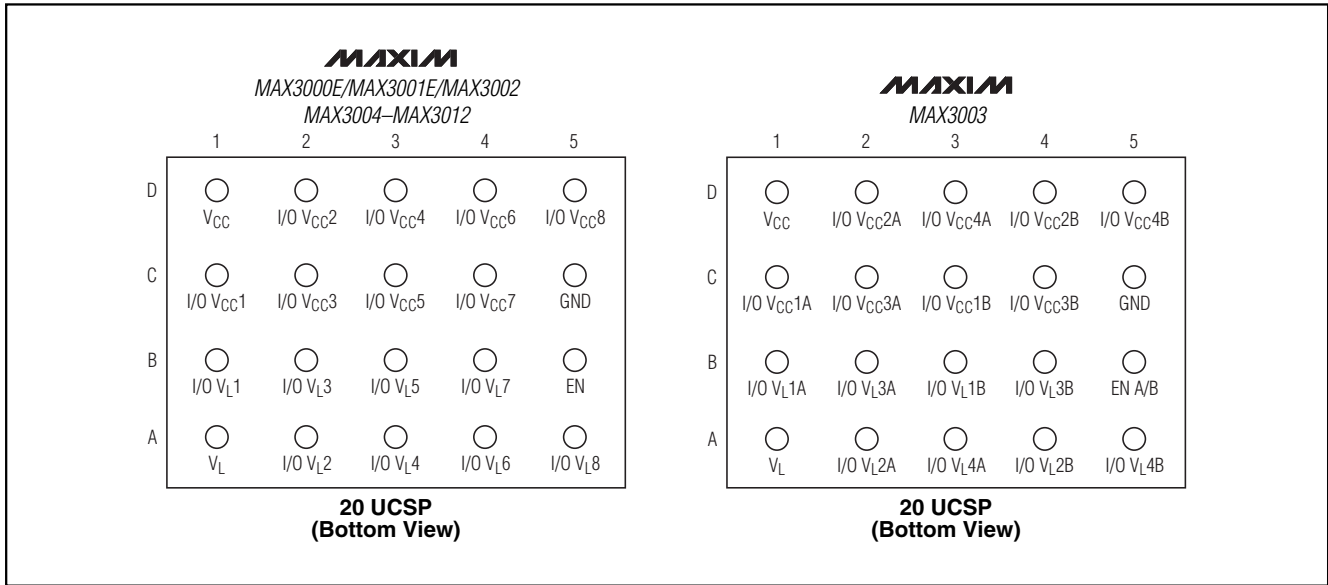

# +1.2V to +5.5V, ±15kV ESD-Protected, 0.1µA, 35Mbps, 8-Channel Level Translators

## Pin Configurations (continued)

**MAX3000E/MAX3001E/MAX3002-MAX3012**

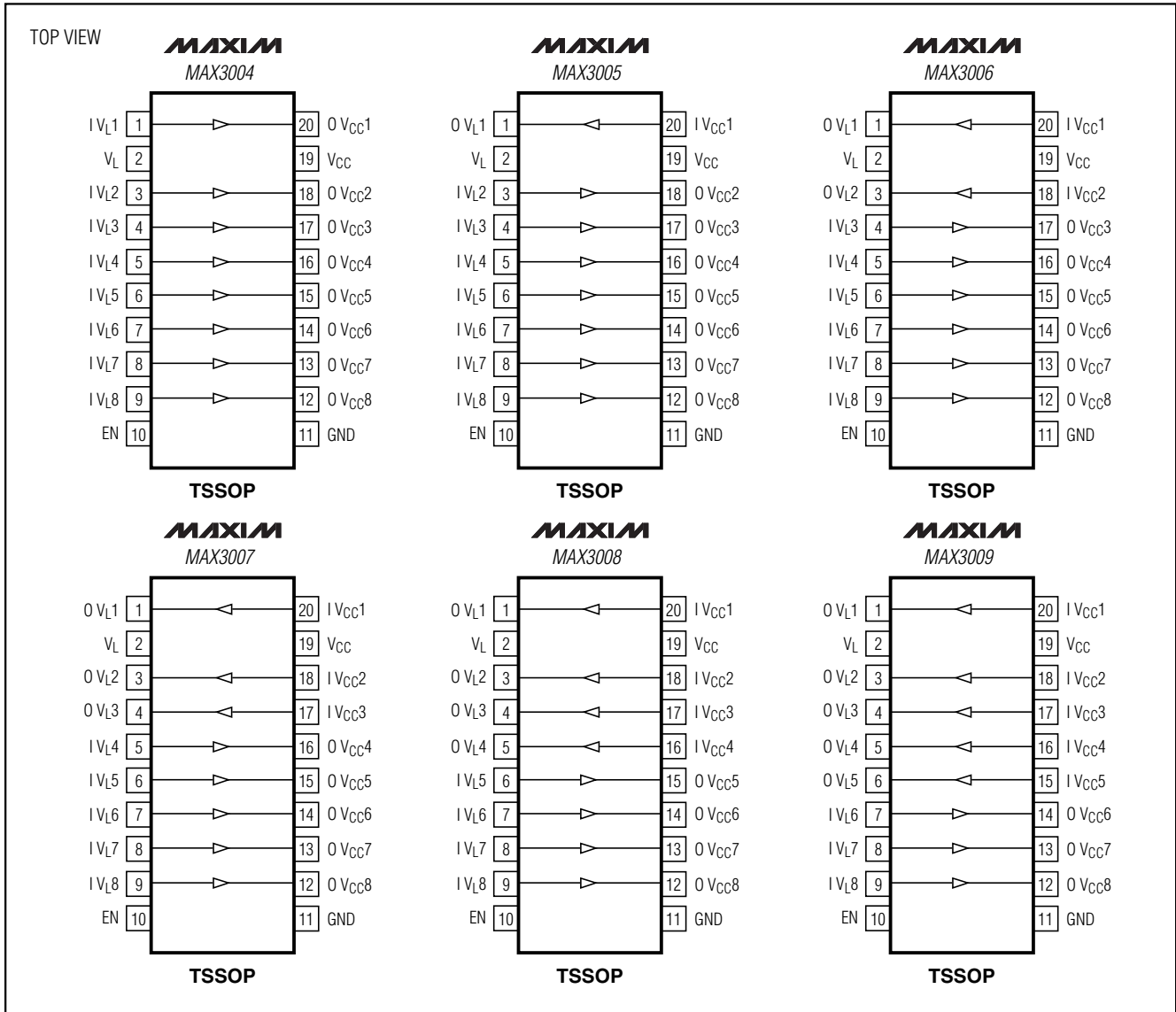

# +1.2V to +5.5V, ±15kV ESD-Protected, 0.1µA, 35Mbps, 8-Channel Level Translators

## Pin Configurations (continued)

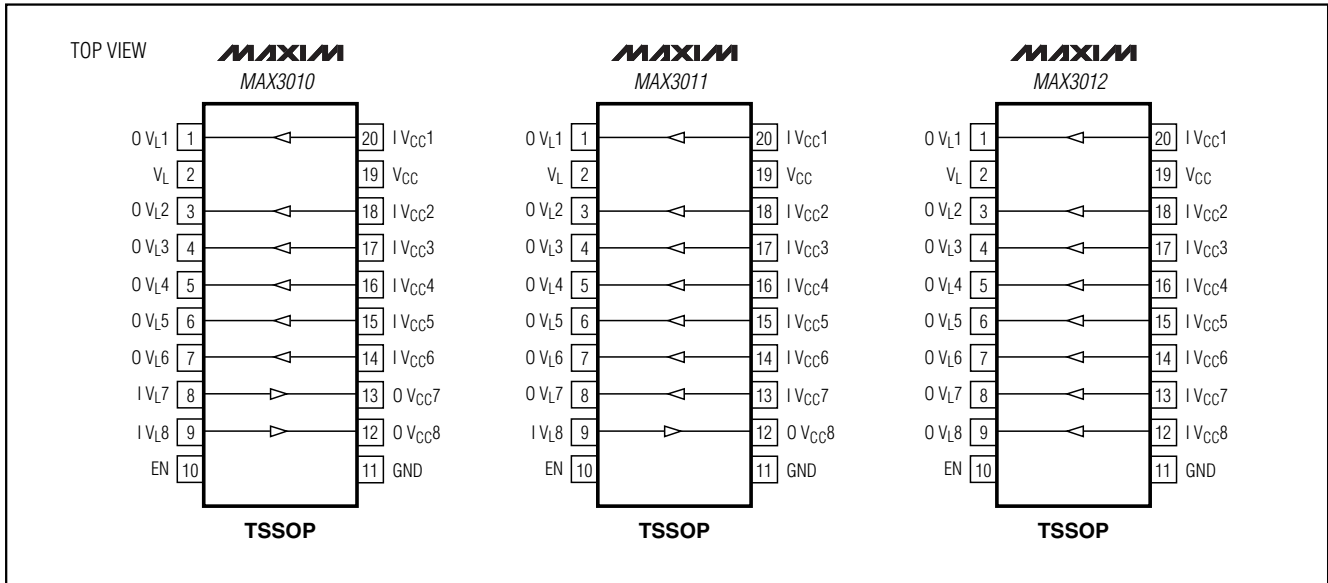

## Ordering Information (continued)

PART	TEMP RANGE	PIN-PACKAGE
<b>MAX3001E</b> EUP	-40°C to +85°C	20 TSSOP
MAX3001E <b>EBP-T*</b>	-40°C to +85°C	4 x 5 UCSP
MAX3001E <b>AUP</b>	-40°C to +125°C	20 TSSOP
<b>MAX3002E</b> UP	-40°C to +85°C	20 TSSOP
MAX3002E <b>BP-T*</b>	-40°C to +85°C	4 x 5 UCSP
<b>MAX3003E</b> UP	-40°C to +85°C	20 TSSOP
MAX3003E <b>BP-T*</b>	-40°C to +85°C	4 x 5 UCSP
<b>MAX3004E</b> UP*	-40°C to +85°C	20 TSSOP
MAX3004E <b>BP-T*</b>	-40°C to +85°C	4 x 5 UCSP
<b>MAX3005E</b> UP*	-40°C to +85°C	20 TSSOP
MAX3005E <b>BP-T*</b>	-40°C to +85°C	4 x 5 UCSP
<b>MAX3006E</b> UP*	-40°C to +85°C	20 TSSOP
MAX3006E <b>BP-T*</b>	-40°C to +85°C	4 x 5 UCSP

PART	TEMP RANGE	PIN-PACKAGE
<b>MAX3007E</b> UP*	-40°C to +85°C	20 TSSOP
MAX3007E <b>BP-T*</b>	-40°C to +85°C	4 x 5 UCSP
<b>MAX3008E</b> UP*	-40°C to +85°C	20 TSSOP
MAX3008E <b>BP-T*</b>	-40°C to +85°C	4 x 5 UCSP
<b>MAX3009E</b> UP*	-40°C to +85°C	20 TSSOP
MAX3009E <b>BP-T*</b>	-40°C to +85°C	4 x 5 UCSP
<b>MAX3010E</b> UP*	-40°C to +85°C	20 TSSOP
MAX3010E <b>BP-T*</b>	-40°C to +85°C	4 x 5 UCSP
<b>MAX3011E</b> UP*	-40°C to +85°C	20 TSSOP
MAX3011E <b>BP-T*</b>	-40°C to +85°C	4 x 5 UCSP
<b>MAX3012E</b> UP*	-40°C to +85°C	20 TSSOP
MAX3012E <b>BP-T*</b>	-40°C to +85°C	4 x 5 UCSP

\*Future product—contact factory for availability.

## Chip Information

TRANSISTOR COUNT: 1184

PROCESS: BiCMOS

# +1.2V to +5.5V, ±15kV ESD-Protected, 0.1µA, 35Mbps, 8-Channel Level Translators

## Package Information

(The package drawing(s) in this data sheet may not reflect the most current specifications. For the latest package outline information, go to [www.maxim-ic.com/packages](http://www.maxim-ic.com/packages).)

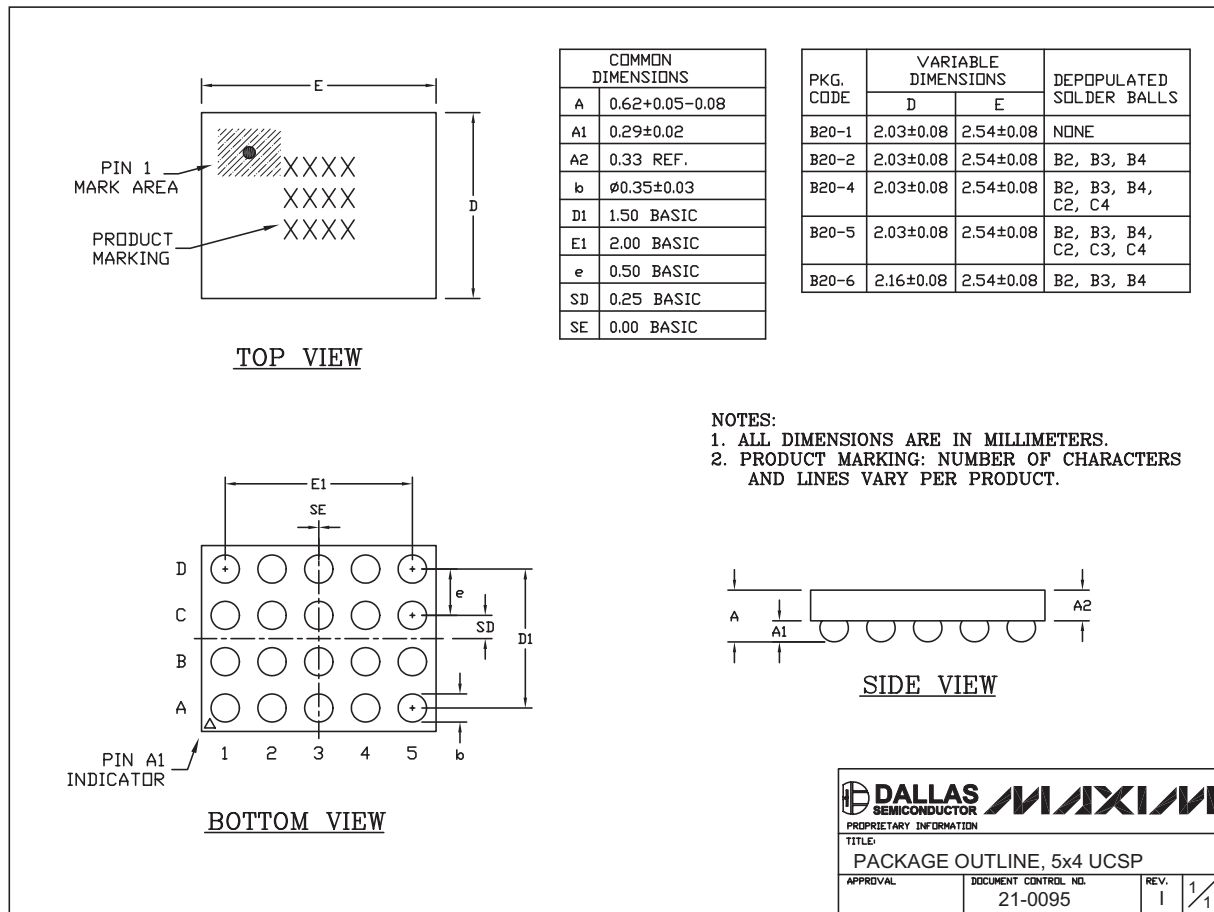

5x4 UCSP EPS

MAX3000E/MAX3001E/MAX3002-MAX3012

# +1.2V to +5.5V, ±15kV ESD-Protected, 0.1µA, 35Mbps, 8-Channel Level Translators

## Package Information (continued)

(The package drawing(s) in this data sheet may not reflect the most current specifications. For the latest package outline information, go to [www.maxim-ic.com/packages](http://www.maxim-ic.com/packages).)

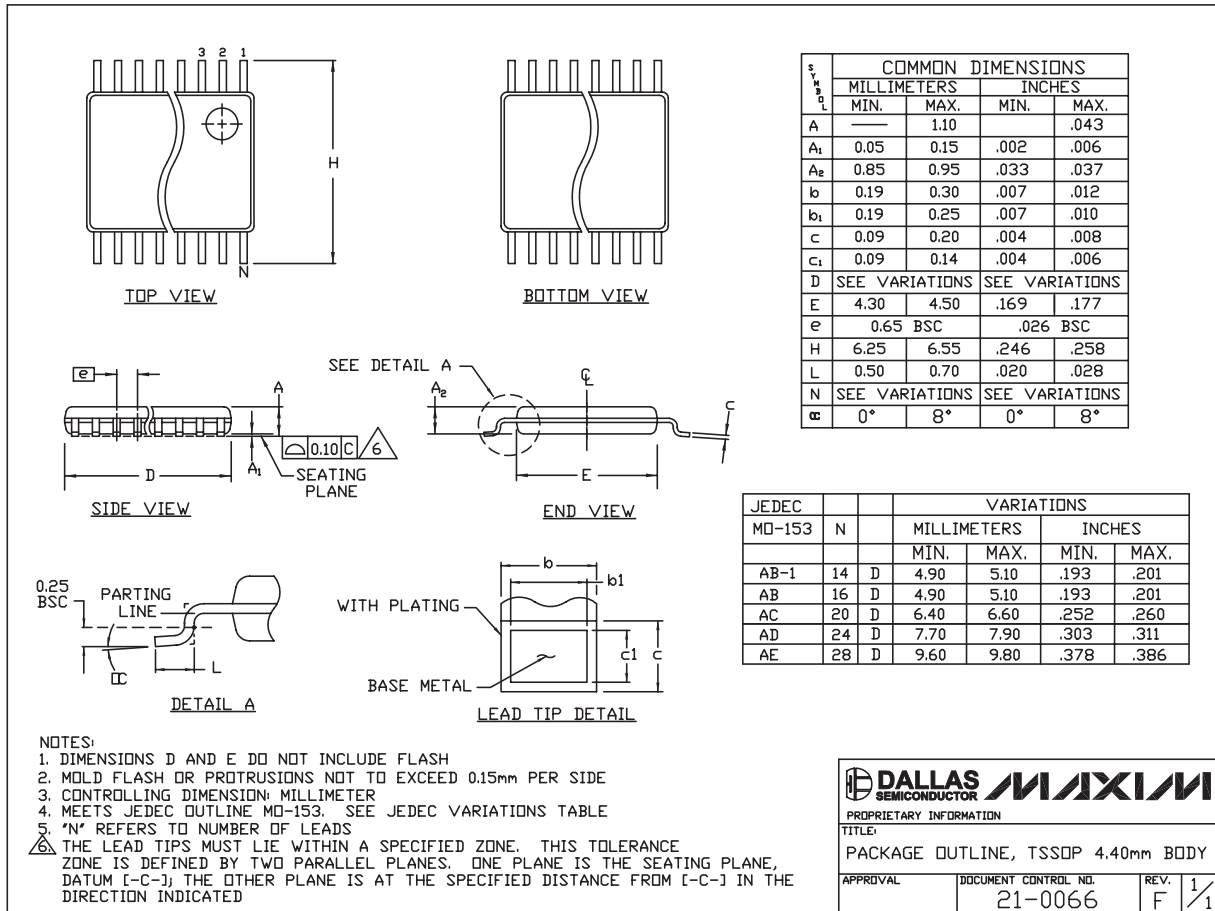

TSSOP4.40mm:EPS

Maxim cannot assume responsibility for use of any circuitry other than circuitry entirely embodied in a Maxim product. No circuit patent licenses are implied. Maxim reserves the right to change the circuitry and specifications without notice at any time.

24 Maxim Integrated Products, 120 San Gabriel Drive, Sunnyvale, CA 94086 408-737-7600

This datasheet has been downloaded from:

[www.DatasheetCatalog.com](http://www.DatasheetCatalog.com)

Datasheets for electronic components.