

DECADE UP-DOWN COUNTER/DECODER/LATCH/DRIVER

- SEPARATE CLOCK-UP AND CLOCK-DOWN LINES
- CAPABLE OF DRIVING COMMON CATHODE LEDES AND OTHER DISPLAYS DIRECTLY
- ALLOWS CASCADING WITHOUT ANY EXTERNAL CIRCUITRY
- MAXIMUM INPUT CURRENT OF 1 μ A AT 18 V (full package-temperature range)
- QUIESCENT CURRENT AT 20 V FOR HCC DEVICE
- 5 V, 10 V AND 15 V PARAMETRIC RATINGS
- INPUT CURRENT OF 100 nA AT 18 V AND 25 °C FOR HCC DEVICE
- 100 % TESTED FOR QUIESCENT CURRENT
- MEETS ALL REQUIREMENTS OF JEDEC TENTATIVE STANDARD No. 13 A, "STANDARD SPECIFICATIONS FOR DESCRIPTION OF "B" SERIES CMOS DEVICES"

DESCRIPTION

The **HCC 40110B** (extended temperature range) and **HCF 40110B** (intermediate temperature range) are monolithic integrated circuits, available in 16-lead dual in-line plastic or ceramic package. The **HCC/HCF 40110B** is a dual-clocked up/down counter with a special preconditioning circuit that allows the counter to be clocked, via positive going inputs, up or down regardless of that state or timing (within 100 ns typ.) of the other clock line. The clock signal is fed into the control logic and Johnson counter after is preconditioned. The outputs of the Johnson counter (which include antilock gating to avoid being locked at an illegal state) are fed into a latch. This data can be fed directly to the decoder through the latch or can be strobed to hold a particular count while the Johnson counter continues to be clocked. The decoder feeds a seven-segment bipolar output driver which can source up to 25 mA to drive LEDs and other displays such as low-voltage fluorescent and incandescent lamps. A short duration negative-going pulse appears on the BORROW output when the count changes from 0 to 9 or the CARRY output when the count changes from 9 to 0. At the other times the BORROW and CARRY output are a logic 1. The CARRY and BORROW outputs can be tied directly to the clock-up and clock-down lines respectively of another HCC/HCF 40110B for easy cascading of several counters.

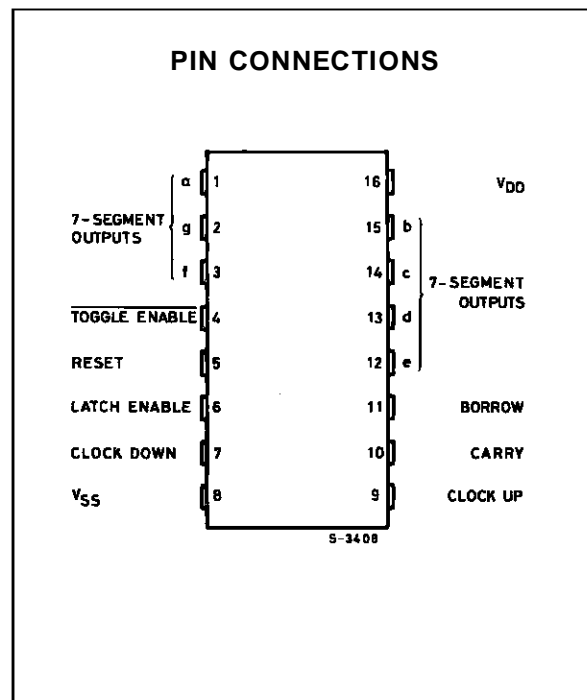
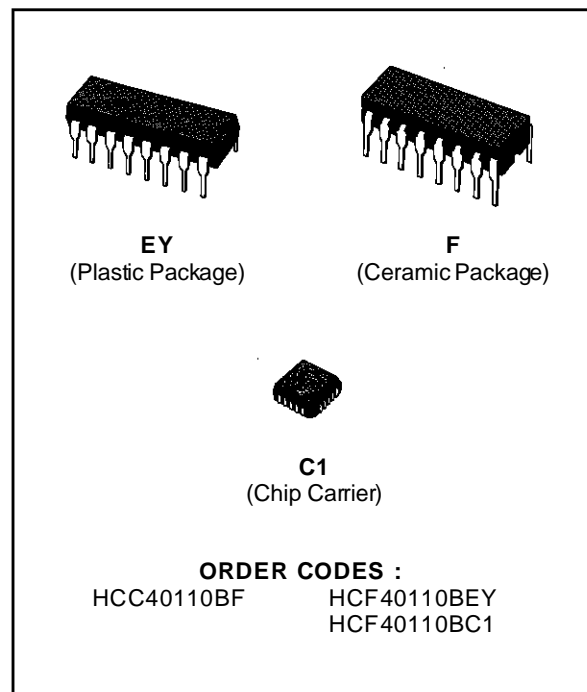

HCC/HCF40110B

FUNCTIONAL DIAGRAM

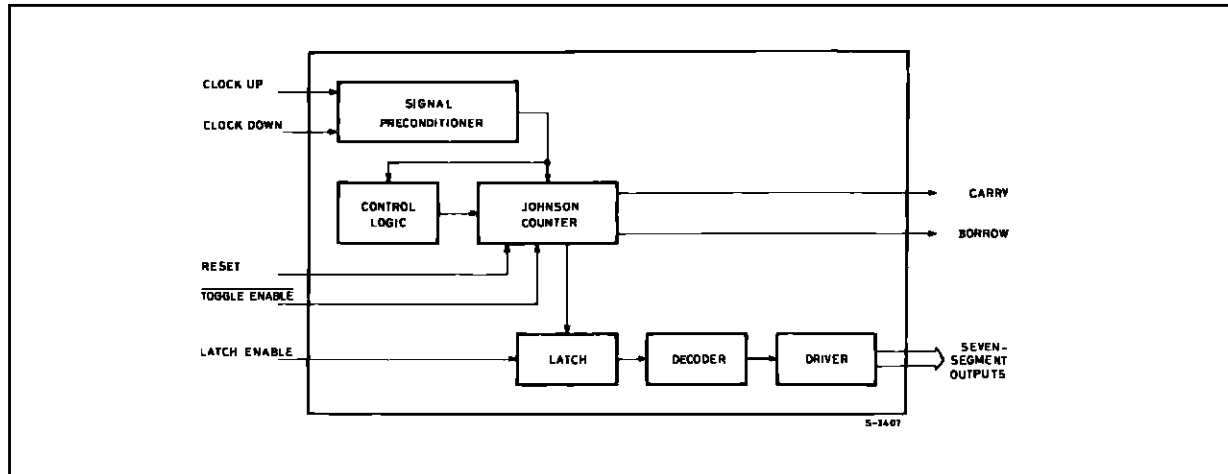

ABSOLUTE MAXIMUM RATING

Symbol	Parameter	Value	Unit
V_{DD}^*	Supply Voltage: HCC Types HCF Types	-0.5 to +20 -0.5 to +18	V V
V_i	Input Voltage	-0.5 to $V_{DD} + 0.5$	V
I_i	DC Input Current (any one input)	± 10	mA
P_{tot}	Total Power Dissipation (per package) Dissipation per Output Transistor for T_{op} = Full Package Temperature Range	200 100	mW mW
T_{op}	Operating Temperature: HCC Types HCF Types	-55 to +125 -40 to +85	$^{\circ}C$ $^{\circ}C$
T_{stg}	Storage Temperature	-65 to +150	$^{\circ}C$

Stresses above those listed under "Absolute Maximum Ratings" may cause permanent damage to the device. This is a stress rating only and functional operation of the device at these or any other conditions above those indicated in the operational sections of this specification is not implied. Exposure to absolute maximum rating conditions for external periods may affect device reliability.

* All voltage values are referred to V_{SS} pin voltage.

RECOMMENDED OPERATING CONDITIONS

Symbol	Parameter	Value	Unit
V_{DD}	Supply Voltage: HCC Types HCF Types	3 to 18 3 to 15	V V
V_i	Input Voltage	0 to V_{DD}	V
T_{op}	Operating Temperature: HCC Types HCF Types	-55 to +125 -40 to +85	$^{\circ}C$ $^{\circ}C$

LOGIC DIAGRAMS

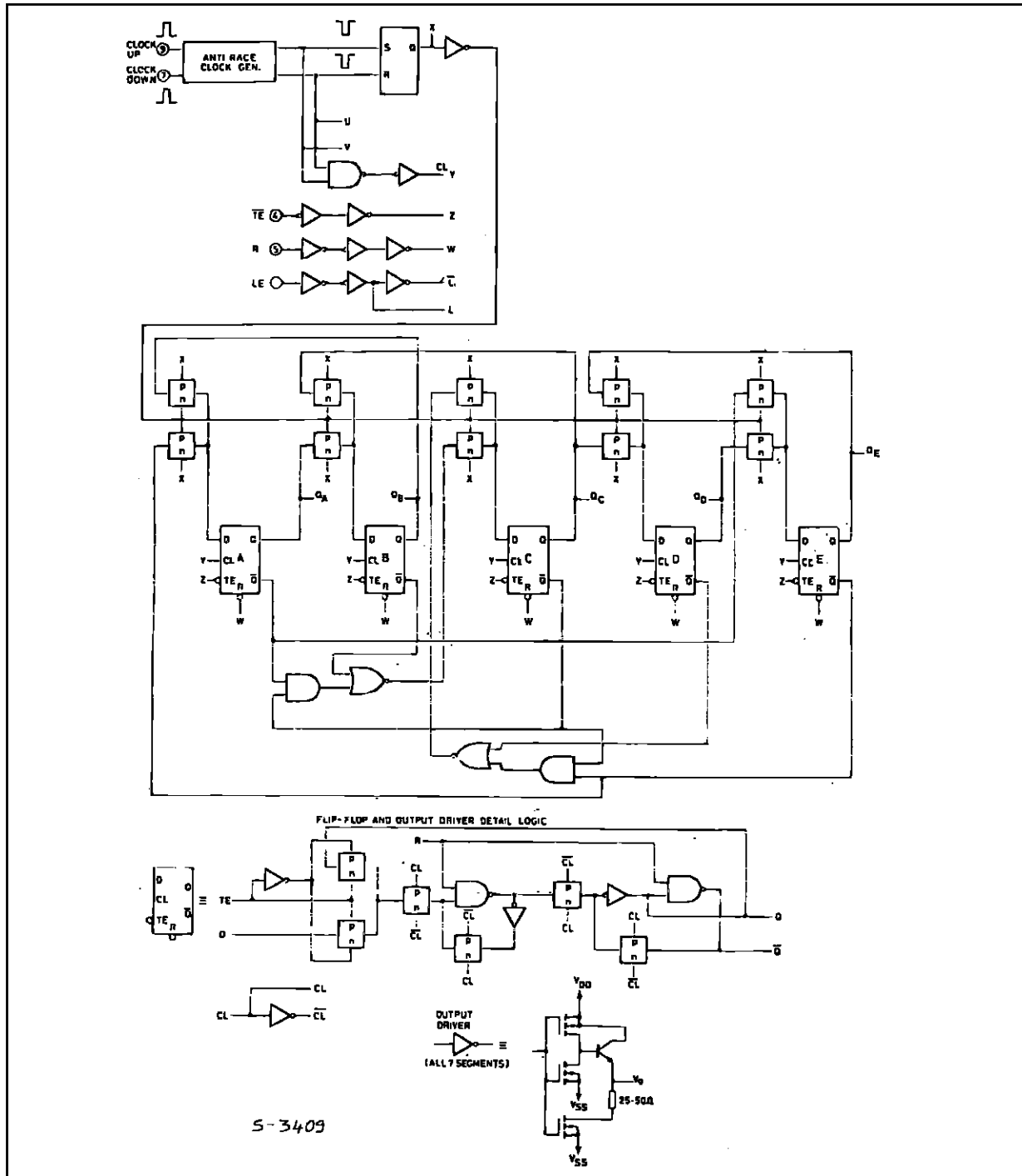

LOGIC DIAGRAM (continued)

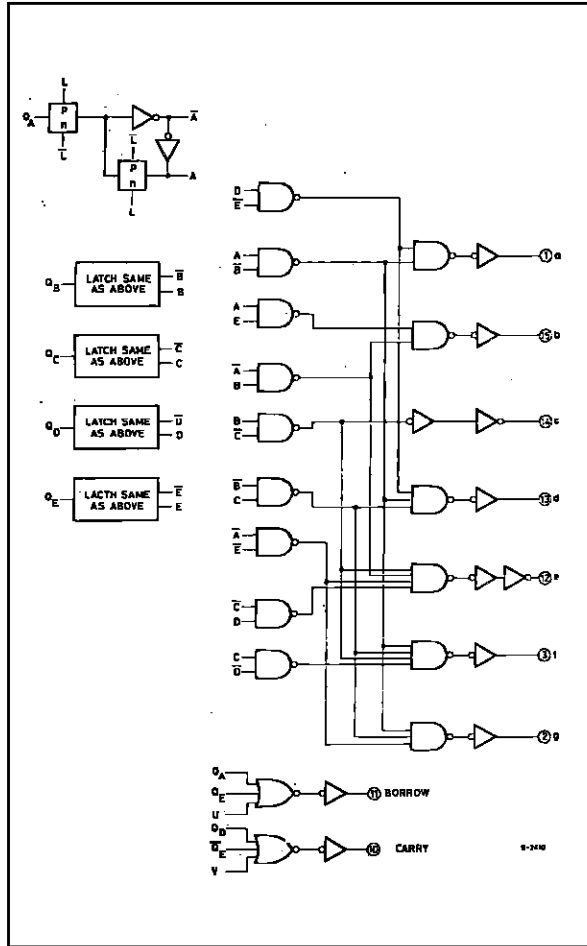

DISPLAY SEGMENTS

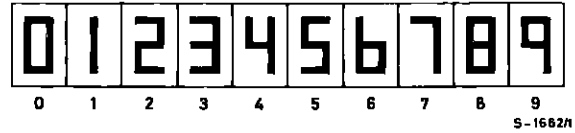
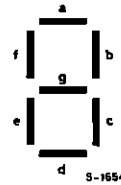

Output Low (sink) Current Characteristics.

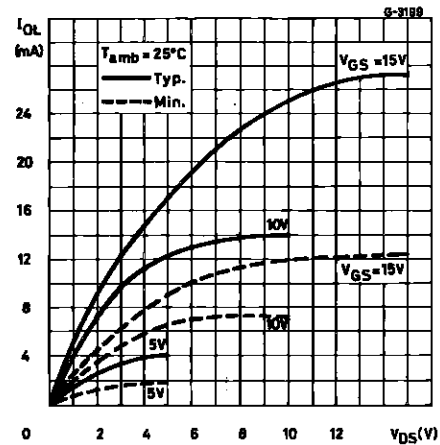

TRUTH TABLE

CLOCK UP*	CLOCK DOWN*	LATCH ENABLE	TOGGLE ENABLE	RESET	COUNTER	DISPLAY
	X	0	0	0	Increments by 1	Follows Counter
X		0	0	0	Decrement by 1	Follows Counter
		X	X	0	No Change	No Change
X	X	X	X	1	Goes to 00000	Follows Counter (Display = 0)
X	X	X	1	0	Inhibited	Remains Fixed
	X	1	0	0	Increments by 1	Remains Fixed
X		1	0	0	Decrement by 1	Remains Fixed

x = Don't care 1 = High State 2 = Low State

* Typically 100 ns between clock-up and clock-down positive transitions are required to ensure proper counting

STATIC ELECTRICAL CHARACTERISTICS (over recommended operating conditions)

Symbol	Parameter		Test Conditions				Value						Unit	
			V _I (V)	V _O (V)	I _o (μ A)	V _{DD} (V)	T _{LOW} *		25 °C			T _{HIGH} *		
							Min.	Max.	Min.	Typ.	Max.	Min.		Max.
I _L	Quiescent Current	HCC Types	0/5			5		5		0.04	5		150	μ A
			0/10			10		10		0.04	10		300	
			0/15			15		15		0.04	20		600	
		0/20			20		20		0.48	100		3000		
		HCF Types	0/5			5		5		0.04	20		150	
			0/10			10		10		0.04	40		300	
0/15				15		15		0.04	80		600			
V _{OH}	Output High Voltage	0/5			5				4.95				V	
		0/10			10				9.55					
		0/15			15				14.55					
V _{OL}	Output Low Voltage	5/0			5		0.05		0	0.05		0.05	V	
		10/0			10		0.05		0	0.05		0.05		
		15/0			15		0.05		0	0.05		0.05		
V _{IH}	Input High Voltage	0.5/3.8			5	3.5		3.5				3.5	V	
		1/8.8			10	7		7				7		
		1.5/3.8			15	11		11				11		
V _{IL}	Input Low Voltage	0.5/3.8			5		1.5			1.5		1.5	V	
		1/8.8			10		3			3		3		
		1.5/3.8			15		4			4		4		
V _{OL}	Output Drive Voltage (for HCC/HCF)	0		5					4.55				V	
		10		5					4.13					
		25		5					3.64					
		0		10					9.55					
		10		10					9.25					
		25		10					8.85					
		0		15					14.55					
		10		15					14.21					
I _{OL}	Output Sink Current	HCC Types	0/5	0.4		5	0.64		0.51	1		0.36	mA	
			0/10	0.5		10	1.6		1.3	2.6		0.9		
			0/15	1.5		15	4.2		3.4	6.8		2.4		
		HCF Types	0/5	0.4		5	0.52		0.44	1		0.36		
			0/10	0.5		10	1.3		1.1	2.6		0.9		
			0/15	1.5		15	3.6		3.0	6.8		2.4		
I _{IH} , I _{IL}	Input Leakage Current	HCC Types	0/18	Any Input		18		\pm 0.1		\pm 10 ⁻⁵	\pm 0.1		\pm 1	μ A
		HCF Types	0/15			15		\pm 0.3		\pm 10 ⁻⁵	\pm 0.3		\pm 1	
C _I	Input Capacitance			Any Input					5	7.5			pF	

* T_{LOW} = -55 °C for HCC device; -40 °C for HCF device.

* T_{HIGH} = +125 °C for HCC device; +85 °C for HCF device.

The Noise Margin for both "1" and "0" level is: 1V min. with V_{DD} = 5V, 2V min. with V_{DD} = 10V, 2.5V min. with V_{DD} = 15V

HCC/HCF40110B

DYNAMIC ELECTRICAL CHARACTERISTICS ($T_{amb} = 25\text{ }^{\circ}\text{C}$, $C_L = 50\text{ pF}$, $R_L = 200\text{ K}\Omega$, typical temperature coefficient for all V_{DD} values is $03\text{ } \%/^{\circ}\text{C}$, all input rise and fall times = 20 ns)

Symbol	Parameter	Test Conditions		Value			Unit
			V_{DD} (V)	Min.	Typ.	Max.	
CLOCK UP/CLOCK DOWN							
t_w	Pulse Width		5		85		ns
			10		35		
			15		15		
f_{CL}	Maximum Frequency		5		2.5		MHz
			10		5		
			15		8		
t_{WC}	Carry Pulse Width		5		225		ns
			10		100		
			15		70		
t_{WB}	Borrow Pulse Width		5		260		ns
			10		110		
			15		80		
RESET							
t_{PLH} t_{PHL}	Propagation Delay Time Reset to Clock		5		750		ns
			10		285		
			15		200		
	Delay from Reset to First Allowable Clock		5		300		ns
		10		125			
		15		75			
t_w	Pulse Width		5		150		ns
			10		60		
			15		40		

TEST CIRCUITS

Quiescent Device Current

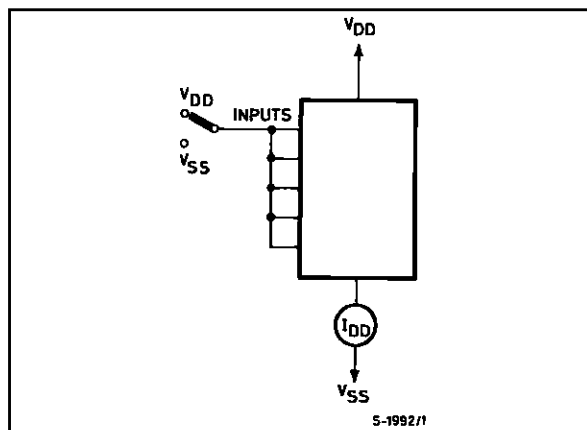

Noise Immunity

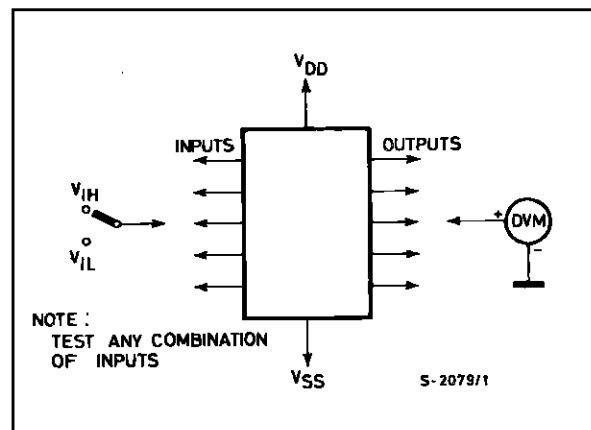

TEST CIRCUITS

Input Leakage Current.

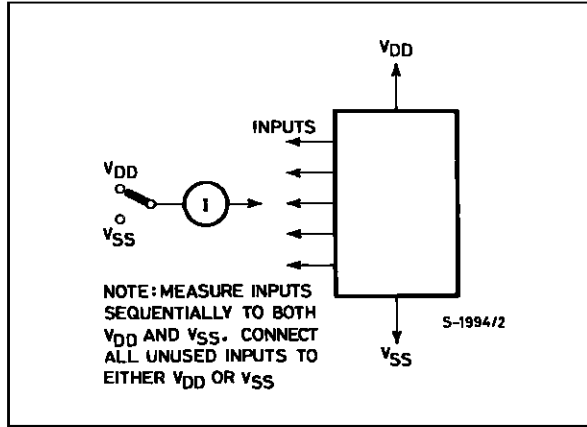

Plastic DIP16 (0.25) MECHANICAL DATA

DIM.	mm			inch		
	MIN.	TYP.	MAX.	MIN.	TYP.	MAX.
a1	0.51			0.020		
B	0.77		1.65	0.030		0.065
b		0.5			0.020	
b1		0.25			0.010	
D			20			0.787
E		8.5			0.335	
e		2.54			0.100	
e3		17.78			0.700	
F			7.1			0.280
I			5.1			0.201
L		3.3			0.130	
Z			1.27			0.050



P001C

Ceramic DIP16/1 MECHANICAL DATA

DIM.	mm			inch		
	MIN.	TYP.	MAX.	MIN.	TYP.	MAX.
A			20			0.787
B			7			0.276
D		3.3			0.130	
E	0.38			0.015		
e3		17.78			0.700	
F	2.29		2.79	0.090		0.110
G	0.4		0.55	0.016		0.022
H	1.17		1.52	0.046		0.060
L	0.22		0.31	0.009		0.012
M	0.51		1.27	0.020		0.050
N			10.3			0.406
P	7.8		8.05	0.307		0.317
Q			5.08			0.200

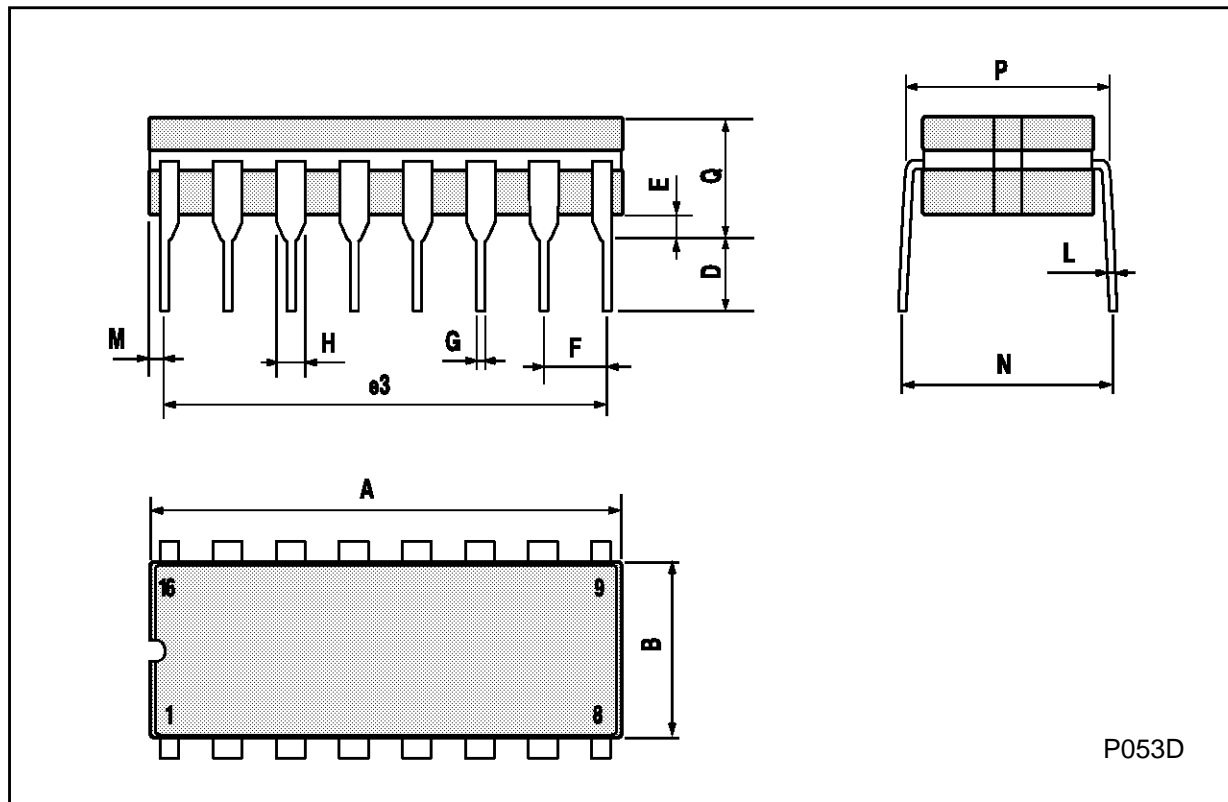

PLCC20 MECHANICAL DATA

DIM.	mm			inch		
	MIN.	TYP.	MAX.	MIN.	TYP.	MAX.
A	9.78		10.03	0.385		0.395
B	8.89		9.04	0.350		0.356
D	4.2		4.57	0.165		0.180
d1		2.54			0.100	
d2		0.56			0.022	
E	7.37		8.38	0.290		0.330
e		1.27			0.050	
e3		5.08			0.200	
F		0.38			0.015	
G			0.101			0.004
M		1.27			0.050	
M1		1.14			0.045	



Information furnished is believed to be accurate and reliable. However, SGS-THOMSON Microelectronics assumes no responsibility for the consequences of use of such information nor for any infringement of patents or other rights of third parties which may result from its use. No license is granted by implication or otherwise under any patent or patent rights of SGS-THOMSON Microelectronics. Specifications mentioned in this publication are subject to change without notice. This publication supersedes and replaces all information previously supplied. SGS-THOMSON Microelectronics products are not authorized for use as critical components in life support devices or systems without express written approval of SGS-THOMSON Microelectronics.

© 1994 SGS-THOMSON Microelectronics - All Rights Reserved

SGS-THOMSON Microelectronics GROUP OF COMPANIES

Australia - Brazil - France - Germany - Hong Kong - Italy - Japan - Korea - Malaysia - Malta - Morocco - The Netherlands -
Singapore - Spain - Sweden - Switzerland - Taiwan - Thailand - United Kingdom - U.S.A

This datasheet has been downloaded from:

www.DatasheetCatalog.com

Datasheets for electronic components.