



Low Power Narrowband FM IF

The MC3361B includes an Oscillator, Mixer, Limiting Amplifier, Quadrature Discriminator, Active Filter, Squelch, Scan Control and Mute Switch. This device is designed for use in FM dual conversion communications equipment.

- Operates from 2.0 to 8.0 V Supply
- Low Drain Current 3.9 mA Typical @ $V_{CC} = 4.0$ Vdc
- Excellent Sensitivity: Input Limiting Voltage -3.0 dB = $2.6 \mu\text{V}$ Typical
- Low Number of External Parts Required
- Operating Frequency Up to 60 MHz

MC3361B

LOW POWER NARROWBAND FM IF

SEMICONDUCTOR TECHNICAL DATA

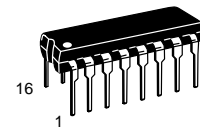

P SUFFIX
PLASTIC PACKAGE
CASE 648

Not Recommended for New Design

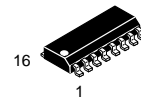

D SUFFIX
PLASTIC PACKAGE
CASE 751B
(SO-16)

Representative Block Diagram

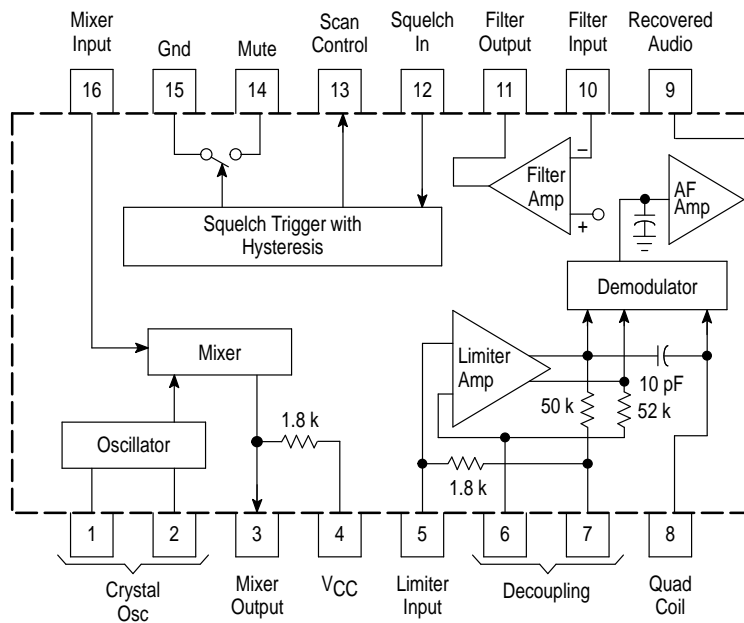

This device contains 92 active transistors.

PIN CONNECTIONS

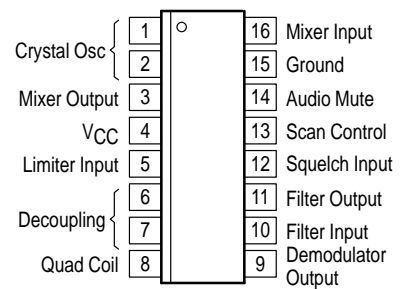

(Top View)

ORDERING INFORMATION

Device	Operating Temperature Range	Package
MC3361BD	$T_A = -30$ to 70°C	SO-16
MC3361BP		Plastic DIP

MC3361B

MAXIMUM RATINGS (T_A = 25°C, unless otherwise noted.)

Rating	Pin	Symbol	Value	Unit
Power Supply Voltage	4	V _{CC(max)}	10	Vdc
Operating Supply Voltage Range	4	V _{CC}	2.0 to 8.0	Vdc
Detector Input Voltage	8	–	1.0	V _{pp}
Input Voltage (V _{CC} ≥ 4.0 V)	16	V ₁₆	1.0	V _{rms}
Mute Function	14	V ₁₄	–0.5 to 5.0	V _{pk}
Junction Temperature	–	T _J	150	°C
Operating Ambient Temperature Range	–	T _A	–30 to 70	°C
Storage Temperature Range	–	T _{stg}	–65 to 150	°C

- NOTES:** 1. Maximum Ratings are those values beyond which damage to the device may occur. Functional operation should be restricted to the limits in the Electrical Characteristics tables or Pin Descriptions section.
2. ESD data available upon request.

ELECTRICAL CHARACTERISTICS (V_{CC} = 4.0 Vdc, f₀ = 10.7 MHz, Δf = ± 3.0 kHz, f_{mod} = 1.0 kHz, T_A = 25°C, unless otherwise noted.)

Characteristic	Pin	Min	Typ	Max	Unit	
Drain Current (No Signal)	4	Squelch "Off"	2.9	3.9	4.9	mA
		Squelch "On"	4.4	5.4	6.4	
Recovered Audio Output Voltage (V _{in} = 10 mVrms)	9	130	160	200	mVrms	
Input Limiting Voltage (–3.0 dB Limiting)	16	–	2.6	6.0	μV	
Total Harmonic Distortion	9	–	0.86	–	%	
Recovered Output Voltage (No Input Signal)	9	60	120	250	mVrms	
Drop Voltage AF Gain Loss	9	–3.0	–0.6	–	dB	
Detector Output Impedance	–	–	450	–	Ω	
Filter Gain (10 kHz) (V _{in} = 0.3 mVrms)	–	40	50	–	dB	
Filter Output Voltage	11	1.0	1.3	1.6	Vdc	
Mute Function Low	14	–	30	50	Ω	
Mute Function High	14	1.0	11	–	MΩ	
Scan Function Low (Mute "Off") (V ₁₂ = 1.0 Vdc)	13	–	0	0.4	Vdc	
Scan Function High (Mute "On") (V ₁₂ = Gnd)	13	3.0	3.5	–	Vdc	
Trigger Hysteresis	–	–	45	100	mV	
Mixer Conversion Gain	3	–	28	–	dB	
Mixer Input Resistance	16	–	3.3	–	kΩ	
Mixer Input Capacitance	16	–	2.2	–	pF	

MC3361B

Figure 1. Test Circuit

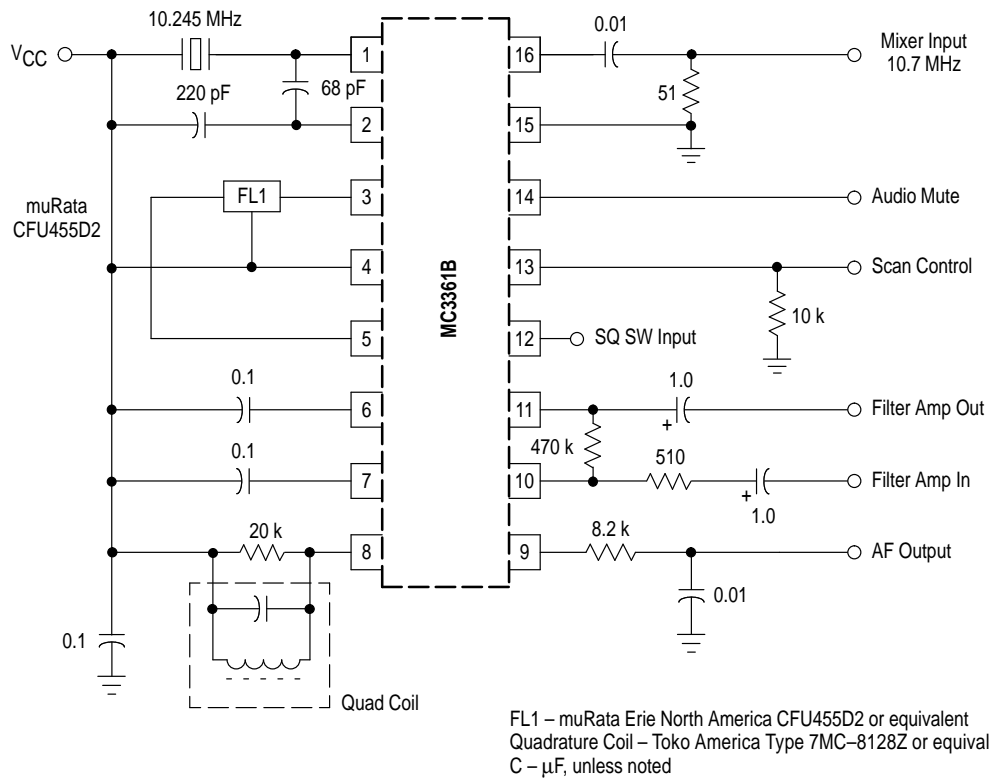

Figure 2. Audio Output, Distortion versus Supply Voltage

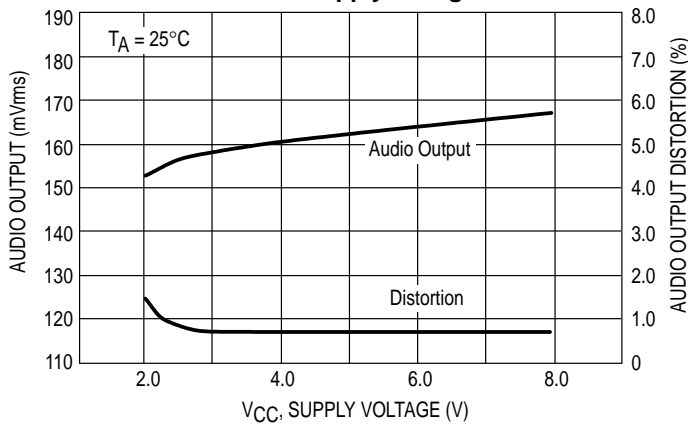

Figure 3. Audio Output, Distortion versus Temperature

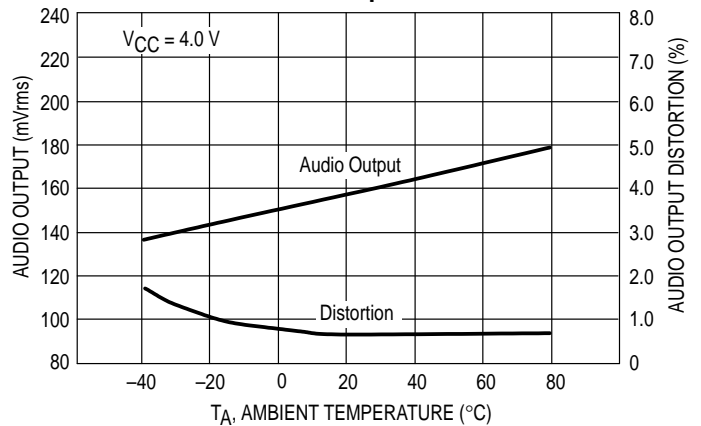

Figure 4. Low Voltage Low Power Narrowband FM IF

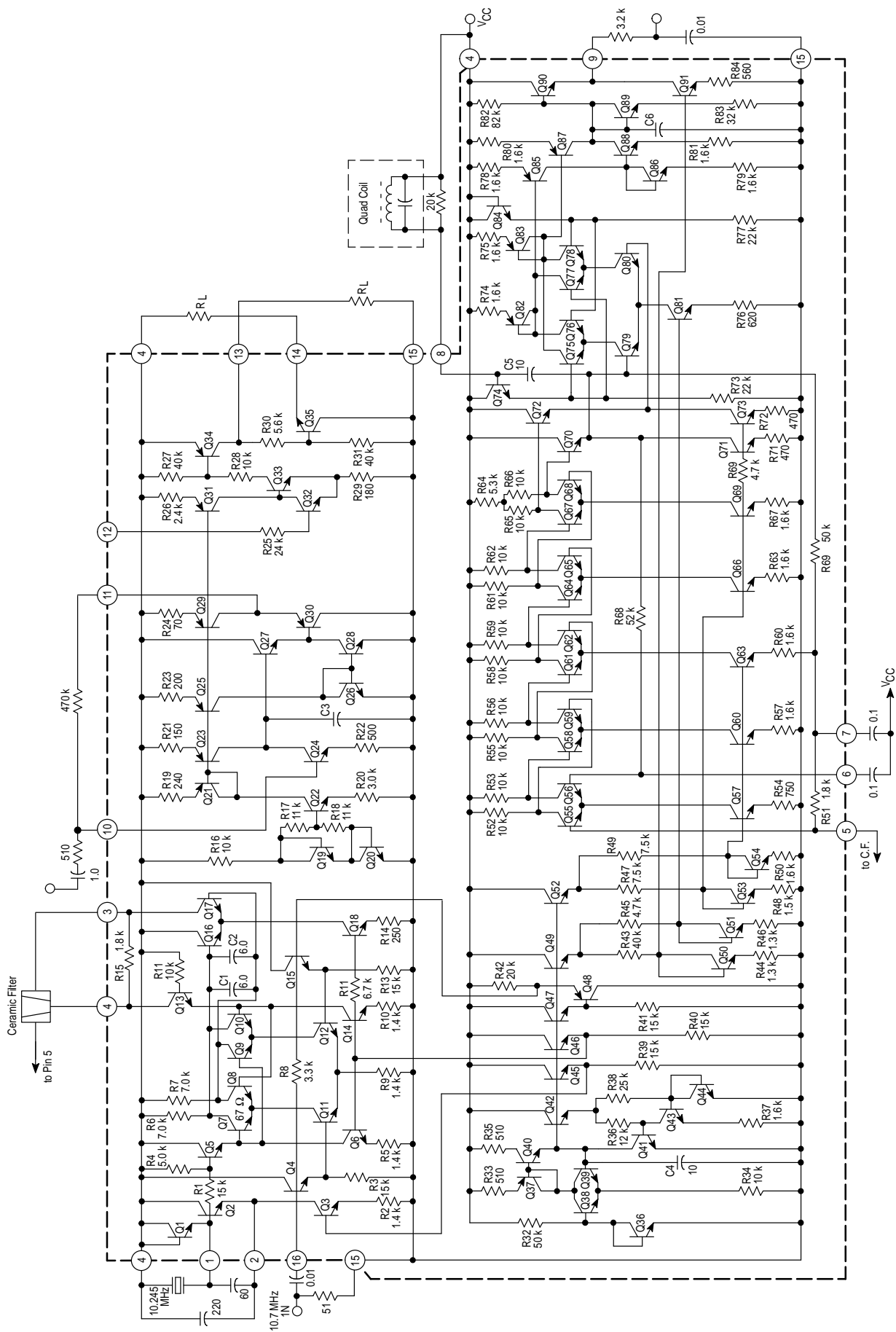

Figure 5. Input Limiting Voltage

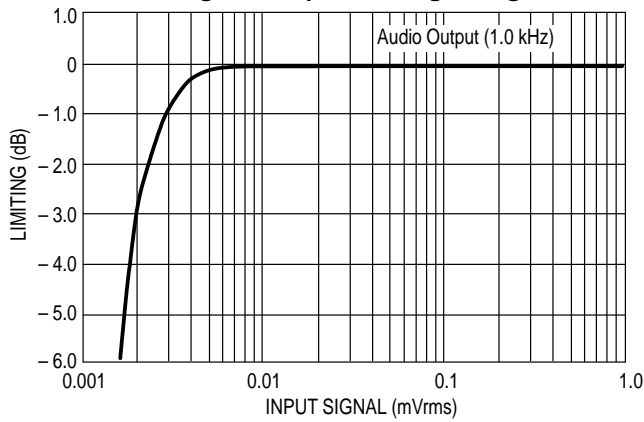

Figure 6. Overall Gain, Noise and AM Rejection

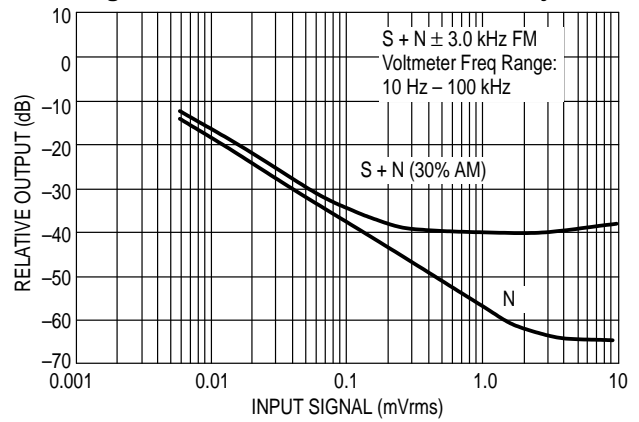

Figure 7. Filter Amp Response

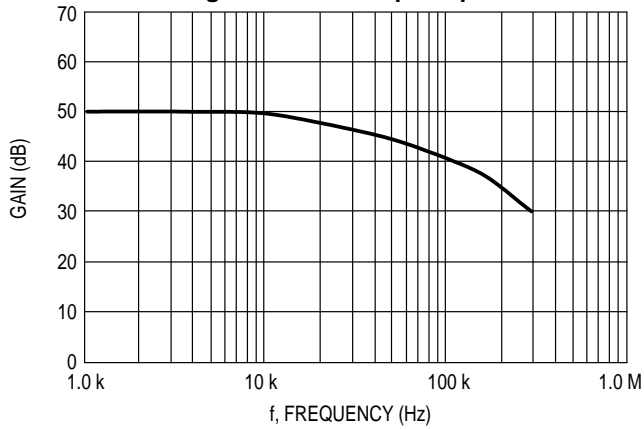

Figure 8. Filter Amp Gain

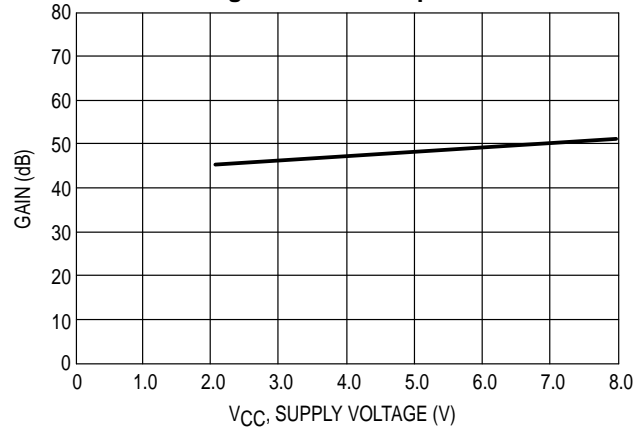
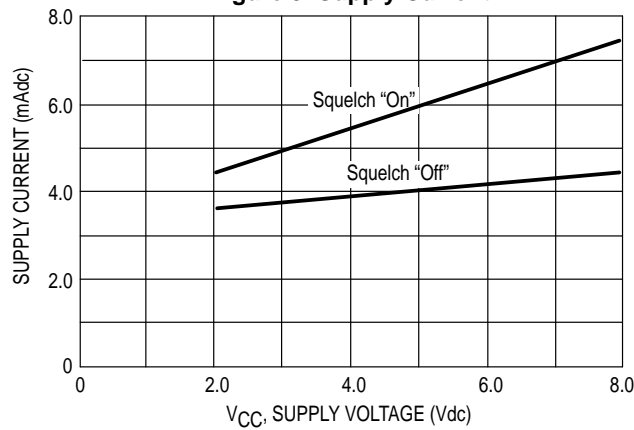

Figure 9. Supply Current



MC3361B

OUTLINE DIMENSIONS

P SUFFIX PLASTIC PACKAGE CASE 648-08 ISSUE R

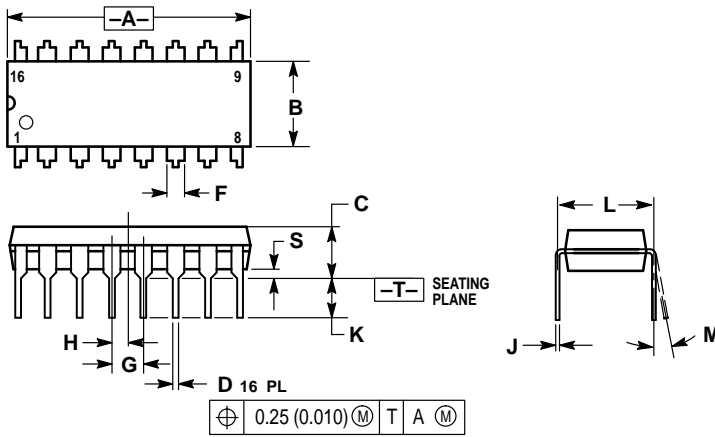

NOTES:

1. DIMENSIONING AND TOLERANCING PER ANSI Y14.5M, 1982.
2. CONTROLLING DIMENSION: INCH.
3. DIMENSION L TO CENTER OF LEADS WHEN FORMED PARALLEL.
4. DIMENSION B DOES NOT INCLUDE MOLD FLASH.
5. ROUNDED CORNERS OPTIONAL.

DIM	INCHES		MILLIMETERS	
	MIN	MAX	MIN	MAX
A	0.740	0.770	18.80	19.55
B	0.250	0.270	6.35	6.85
C	0.145	0.175	3.69	4.44
D	0.015	0.021	0.39	0.53
F	0.040	0.70	1.02	1.77
G	0.100 BSC		2.54 BSC	
H	0.050 BSC		1.27 BSC	
J	0.008	0.015	0.21	0.38
K	0.110	0.130	2.80	3.30
L	0.295	0.305	7.50	7.74
M	0°	10°	0°	10°
S	0.020	0.040	0.51	1.01

D SUFFIX PLASTIC PACKAGE CASE 751B-05 (SO-16) ISSUE J

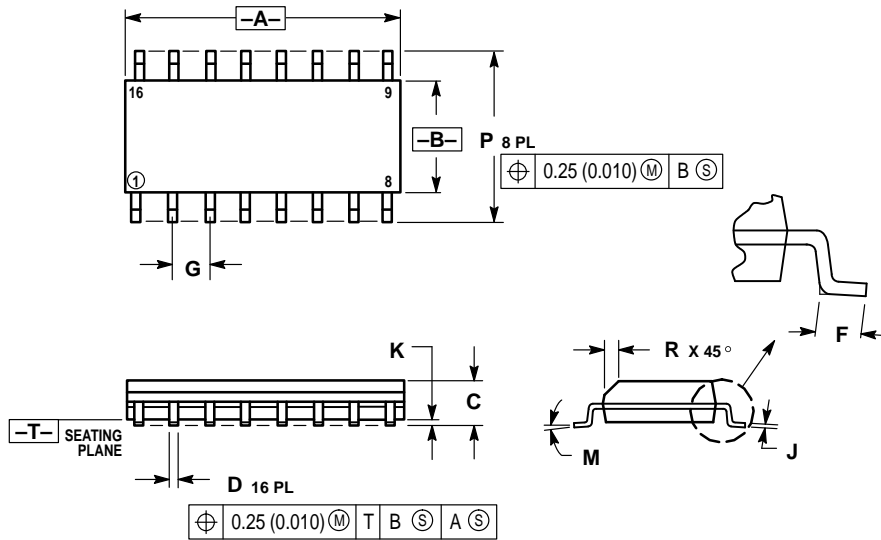

NOTES:

1. DIMENSIONING AND TOLERANCING PER ANSI Y14.5M, 1982.
2. CONTROLLING DIMENSION: MILLIMETER.
3. DIMENSIONS A AND B DO NOT INCLUDE MOLD PROTRUSION.
4. MAXIMUM MOLD PROTRUSION 0.15 (0.006) PER SIDE.
5. DIMENSION D DOES NOT INCLUDE DAMBAR PROTRUSION. ALLOWABLE DAMBAR PROTRUSION SHALL BE 0.127 (0.005) TOTAL IN EXCESS OF THE D DIMENSION AT MAXIMUM MATERIAL CONDITION.

DIM	MILLIMETERS		INCHES	
	MIN	MAX	MIN	MAX
A	9.80	10.00	0.386	0.393
B	3.80	4.00	0.150	0.157
C	1.35	1.75	0.054	0.068
D	0.35	0.49	0.014	0.019
F	0.40	1.25	0.016	0.049
G	1.27 BSC		0.050 BSC	
J	0.19	0.25	0.008	0.009
K	0.10	0.25	0.004	0.009
M	0°	7°	0°	7°
P	5.80	6.20	0.229	0.244
R	0.25	0.50	0.010	0.019

MC3361B

Motorola reserves the right to make changes without further notice to any products herein. Motorola makes no warranty, representation or guarantee regarding the suitability of its products for any particular purpose, nor does Motorola assume any liability arising out of the application or use of any product or circuit, and specifically disclaims any and all liability, including without limitation consequential or incidental damages. "Typical" parameters which may be provided in Motorola data sheets and/or specifications can and do vary in different applications and actual performance may vary over time. All operating parameters, including "Typicals" must be validated for each customer application by customer's technical experts. Motorola does not convey any license under its patent rights nor the rights of others. Motorola products are not designed, intended, or authorized for use as components in systems intended for surgical implant into the body, or other applications intended to support or sustain life, or for any other application in which the failure of the Motorola product could create a situation where personal injury or death may occur. Should Buyer purchase or use Motorola products for any such unintended or unauthorized application, Buyer shall indemnify and hold Motorola and its officers, employees, subsidiaries, affiliates, and distributors harmless against all claims, costs, damages, and expenses, and reasonable attorney fees arising out of, directly or indirectly, any claim of personal injury or death associated with such unintended or unauthorized use, even if such claim alleges that Motorola was negligent regarding the design or manufacture of the part. Motorola and  are registered trademarks of Motorola, Inc. Motorola, Inc. is an Equal Opportunity/Affirmative Action Employer.

Mfax is a trademark of Motorola, Inc.

How to reach us:

USA/EUROPE/Locations Not Listed: Motorola Literature Distribution;
P.O. Box 5405, Denver, Colorado 80217. 1-303-675-2140 or 1-800-441-2447

JAPAN: Motorola Japan Ltd.; SPD, Strategic Planning Office, 141,
4-32-1 Nishi-Gotanda, Shinagawa-ku, Tokyo, Japan. 81-3-5487-8488

Customer Focus Center: 1-800-521-6274

Mfax™: RMFAX0@email.sps.mot.com – TOUCHTONE 1-602-244-6609
Motorola Fax Back System – US & Canada ONLY 1-800-774-1848
– <http://sps.motorola.com/mfax/>

ASIA/PACIFIC: Motorola Semiconductors H.K. Ltd.; Silicon Harbour Centre,
2, Dai King Street, Tai Po Industrial Estate, Tai Po, N.T., Hong Kong.
852-26668334

HOME PAGE: <http://motorola.com/sps/>



MOTOROLA



MC3361B/D

This datasheet has been downloaded from:

www.DatasheetCatalog.com

Datasheets for electronic components.