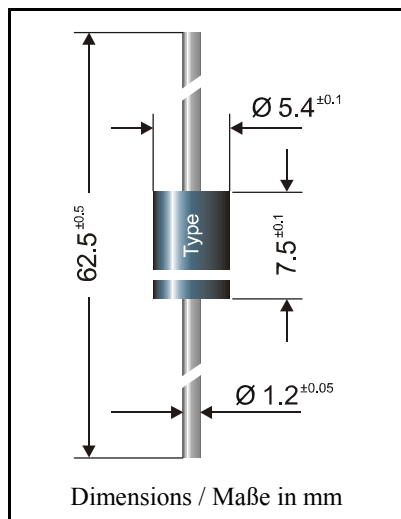

**Unidirectional and bidirectional
Transient Voltage Suppressor Diodes**
**Unidirektionale und bidirektionale
Spannungs-Begrenzer-Dioden**

Peak pulse power dissipation Impuls-Verlustleistung	1500 W
Nominal breakdown voltage Nominale Abbruch-Spannung	6.8...440 V
Plastic case – Kunststoffgehäuse	Ø 5.4 x 7.5 [mm]
Weight approx. – Gewicht ca.	1.1 g
Plastic material has UL classification 94V-0 Gehäusematerial UL94V-0 klassifiziert	
Standard packaging taped in ammo pack Standard Lieferform gegurtet in Ammo-Pack	see page 16 siehe Seite 16

For bidirectional types (suffix “C” or “CA”), electrical characteristics apply in both directions.
Für bidirektionale Dioden (Suffix “C” oder “CA”) gelten die el. Werte in beiden Richtungen.

Maximum ratings and Characteristics
Kenn- und Grenzwerte

Peak pulse power dissipation (10/1000 μ s waveform) Impuls-Verlustleistung (Strom-Impuls 10/1000 μ s)	$T_A = 25^\circ\text{C}$	P_{PPM}	1500 W ¹⁾
Steady state power dissipation Verlustleistung im Dauerbetrieb	$T_A = 25^\circ\text{C}$	$P_{\text{M(AV)}}$	6.5 W ²⁾
Peak forward surge current, 60 Hz half sine-wave Stoßstrom für eine 60 Hz Sinus-Halbwelle	$T_A = 25^\circ\text{C}$	I_{FSM}	200 A ³⁾
Operating junction temperature – Sperrschichttemperatur Storage temperature – Lagerungstemperatur		T_j T_s	$-50...+175^\circ\text{C}$ $-50...+175^\circ\text{C}$
Max. instantaneous forward voltage Augenblickswert der Durchlaßspannung	$I_F = 100\text{ A}$	$V_{\text{BR}} \leq 200\text{ V}$ $V_{\text{BR}} > 200\text{ V}$	$V_F < 3.5\text{ V}^3)$ $V_F < 5.0\text{ V}^3)$
Thermal resistance junction to ambient air Wärmewiderstand Sperrschicht – umgebende Luft		R_{thA}	$< 23\text{ K/W}^2)$
Thermal resistance junction to lead Wärmewiderstand Sperrschicht – Anschlußdraht		R_{thL}	$< 8\text{ K/W}$

¹⁾ Non-repetitive current pulse see curve $I_{\text{PPM}} = f(t_r)$

Höchstzulässiger Spitzenwert eines einmaligen Strom-Impulses, siehe Kurve $I_{\text{PPM}} = f(t_r)$

²⁾ Valid, if leads are kept at ambient temperature at a distance of 10 mm from case

Gültig, wenn die Anschlußdrähte in 10 mm Abstand von Gehäuse auf Umgebungstemperatur gehalten werden

³⁾ Unidirectional diodes only – nur für unidirektionale Dioden

Maximum ratings
Grenzwerte

Type Typ	Breakdown voltage at $I_T = 1$ mA Abbruch-Spanng. bei $I_T = 1$ mA) at / bei $I_T = 10$ mA		Stand-off voltage Sperrspg. V_{WM} [V]	Max. rev. current Max. Sperrstrom at / bei V_{WM} I_D [μ A]	Max. clamping voltage Max. Begrenzerspanng. at / bei I_{PPM} (10/1000 μ s) V_C [V] I_{PPM} [A]	
	V_{BR} [V]				V_C [V]	I_{PPM} [A]
1.5 KE6.8	6.8 \pm 10%	6.12...7.48 *)	5.5	1000	10.8	145
1.5 KE6.8A	6.8 \pm 5%	6.45...7.14 *)	5.8	1000	10.5	150
1.5 KE7.5	7.5 \pm 10%	6.75...8.25 *)	6.0	500	11.7	134
1.5 KE7.5A	7.5 \pm 5%	7.13...7.88 *)	6.4	500	11.3	139
1.5 KE8.2	8.2 \pm 10%	7.38...9.02 *)	6.6	200	12.5	126
1.5 KE8.2A	8.2 \pm 5%	7.79...8.61 *)	7.0	200	12.1	130
1.5 KE9.1	9.1 \pm 10%	8.19...10.0	7.3	50	13.8	114
1.5 KE9.1A	9.1 \pm 5%	8.65...9.55	7.7	50	13.4	117
1.5 KE10	10 \pm 10%	9.0...11.0	8.1	10	15.0	105
1.5 KE10A	10 \pm 5%	9.5...10.5	8.5	10	14.5	108
1.5 KE11	11 \pm 10%	9.9...12.1	8.9	5	16.2	97
1.5 KE11A	11 \pm 5%	10.5...11.6	9.4	5	15.6	100
1.5 KE12	12 \pm 10%	10.8...13.2	9.7	5	17.3	91
1.5 KE12A	12 \pm 5%	11.4...12.6	10.2	5	16.7	94
1.5 KE13	13 \pm 10%	11.7...14.3	10.5	5	19.0	82
1.5 KE13A	13 \pm 5%	12.4...13.7	11.1	5	18.2	86
1.5 KE15	15 \pm 10%	13.5...16.5	12.1	5	22.0	71
1.5 KE15A	15 \pm 5%	14.3...15.8	12.8	5	21.2	74
1.5 KE16	16 \pm 10%	14.4...17.6	12.9	5	23.5	67
1.5 KE16A	16 \pm 5%	15.2...16.8	13.6	5	22.5	70
1.5 KE18	18 \pm 10%	16.2...19.8	14.5	5	26.5	59
1.5 KE18A	18 \pm 5%	17.1...18.9	15.3	5	25.5	60
1.5 KE20	20 \pm 10%	18.0...22.0	16.2	5	29.1	54
1.5 KE20A	20 \pm 5%	19.0...21.0	17.1	5	27.7	56
1.5 KE22	22 \pm 10%	19.8...24.2	17.8	5	31.9	49
1.5 KE22A	22 \pm 5%	20.9...23.1	18.8	5	30.6	51
1.5 KE24	24 \pm 10%	21.6...26.4	19.4	5	34.7	45
1.5 KE24A	24 \pm 5%	22.8...25.2	20.5	5	33.2	47
1.5 KE27	27 \pm 10%	24.3...29.7	21.8	5	39.1	40
1.5 KE27A	27 \pm 5%	25.7...28.4	23.1	5	37.5	42
1.5 KE30	30 \pm 10%	27.0...33.0	24.3	5	43.5	36
1.5 KE30A	30 \pm 5%	28.5...31.5	25.6	5	41.4	38
1.5 KE33	33 \pm 10%	29.7...36.3	26.8	5	47.7	33
1.5 KE33A	33 \pm 5%	31.4...34.7	28.2	5	45.7	34
1.5 KE36	36 \pm 10%	32.4...39.6	29.1	5	52.0	30
1.5 KE36A	36 \pm 5%	34.2...37.8	30.8	5	49.9	31
1.5 KE39	39 \pm 10%	35.1...42.9	31.6	5	56.4	27
1.5 KE39A	39 \pm 5%	37.1...41.0	33.3	5	53.9	29
1.5 KE43	43 \pm 10%	38.7...47.3	34.8	5	61.9	25
1.5 KE43A	43 \pm 5%	40.9...45.2	36.8	5	59.3	26
1.5 KE47	47 \pm 10%	42.3...51.7	38.1	5	67.8	23
1.5 KE47A	47 \pm 5%	44.7...49.4	40.2	5	64.8	24
1.5 KE51	51 \pm 10%	45.9...56.1	41.3	5	73.5	21

Maximum ratings

Grenzwerte

Type Typ	Breakdown voltage at $I_T = 1$ mA Abbruch-Spanng. bei $I_T = 1$ mA *) at / bei $I_T = 10$ mA		Stand-off voltage Sperrspg. V_{WM} [V]	Max. rev. current Max. Sperrstrom at / bei V_{WM} I_D [μ A]	Max. clamping voltage Max. Begrenzerspanng. at / bei I_{PPM} (10/1000 μ s) V_C [V] I_{PPM} [A]	
	V_{BR} [V]					
1.5 KE51A	51 \pm 5%	48.5...53.6	43.6	5	70.1	22
1.5 KE56	56 \pm 10%	50.4...61.6	45.4	5	80.5	19
1.5 KE56A	56 \pm 5%	53.2...58.8	47.8	5	77.0	20
1.5 KE62	62 \pm 10%	55.8...68.8	50.2	5	89.0	17
1.5 KE62A	62 \pm 5%	58.9...65.1	53.0	5	85.0	18
1.5 KE68	68 \pm 10%	61.2...74.8	55.1	5	98.0	16.0
1.5 KE68A	68 \pm 5%	64.6...71.4	58.1	5	92.0	17.0
1.5 KE75	75 \pm 10%	67.5...82.5	60.7	5	108	14.0
1.5 KE75A	75 \pm 5%	71.3...78.8	64.1	5	103	15.0
1.5 KE82	82 \pm 10%	73.8...90.2	66.4	5	118	13.0
1.5 KE82A	82 \pm 5%	77.9...86.1	70.1	5	113	13.9
1.5 KE91	91 \pm 10%	81.9...100	73.7	5	131	12.0
1.5 KE91A	91 \pm 5%	86.5...95.5	77.8	5	125	12.6
1.5 KE100	100 \pm 10%	90.0...110	81.0	5	144	10.9
1.5 KE100A	100 \pm 5%	95.0...105	85.5	5	137	11.4
1.5 KE110	110 \pm 10%	99.0...121	89.2	5	158	9.9
1.5 KE110A	110 \pm 5%	105...116	94.0	5	152	10.3
1.5 KE120	120 \pm 10%	108...132	97.2	5	173	9.1
1.5 KE120A	120 \pm 5%	114...126	102	5	165	9.5
1.5 KE130	130 \pm 10%	117...143	105	5	187	8.4
1.5 KE130A	130 \pm 5%	124...137	111	5	179	8.7
1.5 KE150	150 \pm 10%	135...165	121	5	215	7.3
1.5 KE150A	150 \pm 5%	143...158	128	5	207	7.6
1.5 KE160	160 \pm 10%	144...176	130	5	230	6.8
1.5 KE160A	160 \pm 5%	152...168	136	5	219	7.1
1.5 KE170	170 \pm 10%	153...187	138	5	244	6.4
1.5 KE170A	170 \pm 5%	162...179	145	5	234	6.7
1.5 KE180	180 \pm 10%	162...198	146	5	258	6.1
1.5 KE180A	180 \pm 5%	171...189	154	5	246	6.4
1.5 KE200	200 \pm 10%	180...220	162	5	287	5.4
1.5 KE200A	200 \pm 5%	190...210	171	5	274	5.7
1.5 KE220	220 \pm 10%	198...242	175	5	344	4.5
1.5 KE220A	220 \pm 5%	209...231	185	5	328	4.8
1.5 KE250	250 \pm 10%	225...275	202	5	360	4.3
1.5 KE250A	250 \pm 5%	237...263	214	5	344	4.5
1.5 KE300	300 \pm 10%	270...330	243	5	430	3.6
1.5 KE300A	300 \pm 5%	285...315	256	5	414	3.8
1.5 KE350	350 \pm 10%	315...385	284	5	504	3.1
1.5 KE350A	350 \pm 5%	332...368	300	5	482	3.2
1.5 KE400	400 \pm 10%	360...440	324	5	574	2.7
1.5 KE400A	400 \pm 5%	380...420	342	5	548	2.8
1.5 KE440	440 \pm 10%	396...484	356	5	631	2.4
1.5 KE440A	440 \pm 5%	418...462	376	5	602	2.6

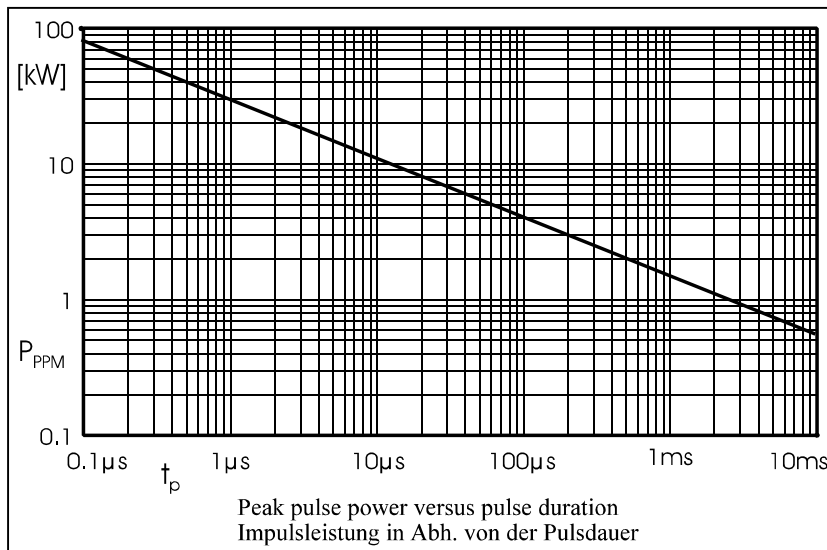
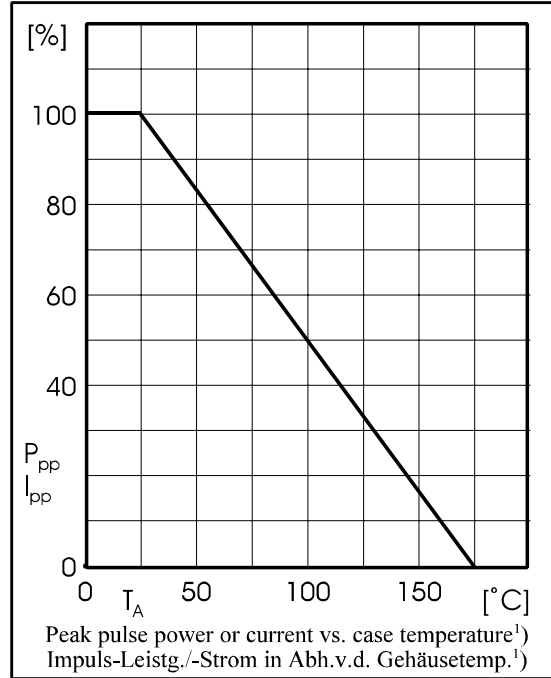
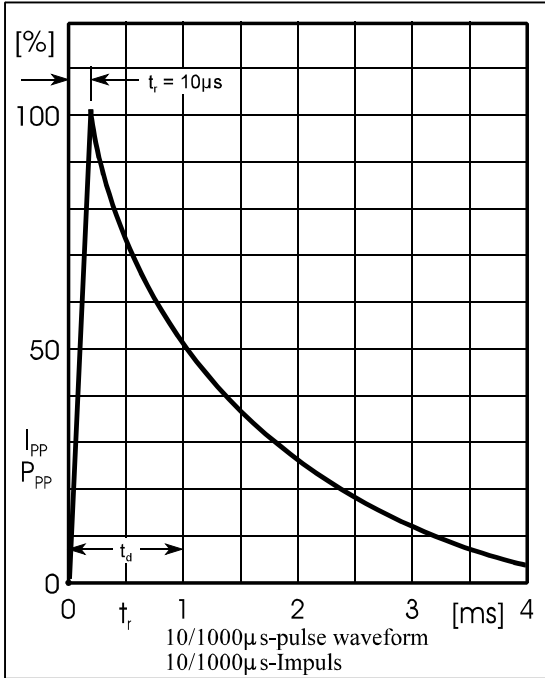

The order of type numbers is graded to the international E 24 standard. The standard tolerance of the breakdown voltage for each type is $\pm 10\%$. Suffix “A” denotes a tolerance of $\pm 5\%$.

e.g.: 1.5KE160CA = bidirectional diode, $V_{BR} = 160 \text{ V} (\pm 5\%)$, $V_{WM} \geq 136 \text{ V}$ at $I_D = 5 \mu\text{A}$
1.5KE7.5A = unidirectional diode, $V_{BR} = 7.5 \text{ V} (\pm 5\%)$, $V_{WM} \geq 6.4 \text{ V}$ at $I_D = 500 \mu\text{A}$

Die Abstufung der Typen innerhalb der Reihe entspricht dem internationalen E 24-Standard. Die Toleranz der Arbeitsspannung jedes einzelnen Typs beträgt in der Standardausführung $\pm 10\%$. Suffix “A” kennzeichnet eine Toleranz $\pm 5\%$.

z.B.: 1.5KE160CA = bidirektionale Diode, $V_{BR} = 160 \text{ V} (\pm 5\%)$, $V_{WM} \geq 136 \text{ V}$ at $I_D = 5 \mu\text{A}$
1.5KE7.5A = unidirektionale Diode, $V_{BR} = 7.5 \text{ V} (\pm 5\%)$, $V_{WM} \geq 6.4 \text{ V}$ at $I_D = 500 \mu\text{A}$

¹⁾ Valid, if leads are kept at ambient temperature at a distance of 10 mm from case
Gültig, wenn die Anschlußdrähte in 10 mm Abstand von Gehäuse auf Umgebungstemperatur gehalten werden

This datasheet has been downloaded from:

www.DatasheetCatalog.com

Datasheets for electronic components.