

6.1 Switch Safely

The following circuit examples have been harmonized with the German Trade Association (BG) and have been approved.

- Contactor circuits
- SIGUARD safety combinations using contactors using safety relays

Suitable for:

- EMERGENCY OFF
- Protective door monitoring functions
- Press controls

EMERGENCY OFF circuits for extremely simple machines

EMERGENCY OFF switch

The EMERGENCY OFF function may only be fed through an EMERGENCY OFF switch for extremely simple machines, depending on the result of a risk analysis. In this particular case, only Stop Category 0 is possible. Such an EMERGENCY OFF switch switches, contrary to usual EMERGENCY OFF pushbuttons, the main circuit (circuit diagram 6/1).

An EMERGENCY OFF switch must be configured, so that

- There is only one EMERGENCY OFF switch;
- the EMERGENCY OFF switch is located in the supply to those circuits which can result in hazardous motion in the system. The complete power supply to all of the circuits does not have to be interrupted;
- the EMERGENCY OFF switch must be able to interrupt the current of the largest motor when the motor stalls;
- the sum of the currents of all of the loads which must be disconnected using the EMERGENCY OFF switch must be able to be safely interrupted.

An EMERGENCY OFF switch may

- be manually actuated;
- act on an undervoltage release via one or several EMERGENCY OFF control devices (circuit diagram 6/1);
- be provided with overload- and/or short-circuit releases (version as circuit-breaker);

- be simultaneously used as main switch, if it additionally fulfills the requirements for a main switch (however, a main switch must disconnect all circuits).

An example for such an EMERGENCY OFF switch for extremely simple machines is illustrated in circuit diagram 6/2.

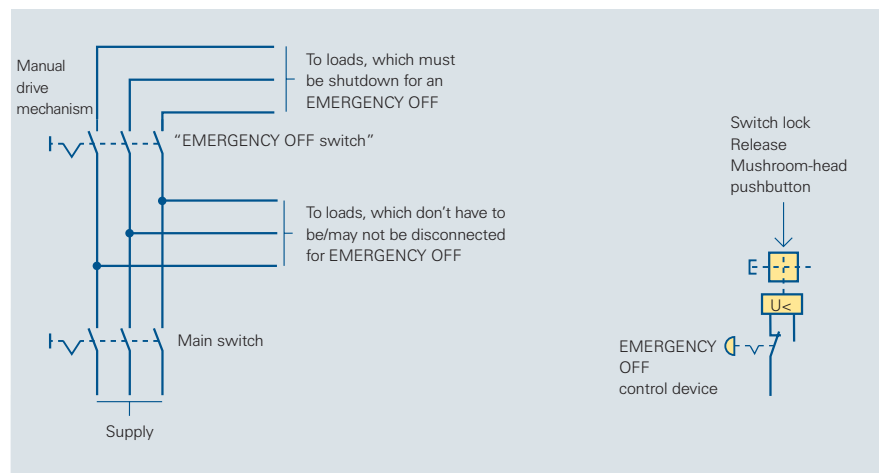

Circuit diagram 6/1
EMERGENCY OFF switch with manual actuation or remote actuation via undervoltage release

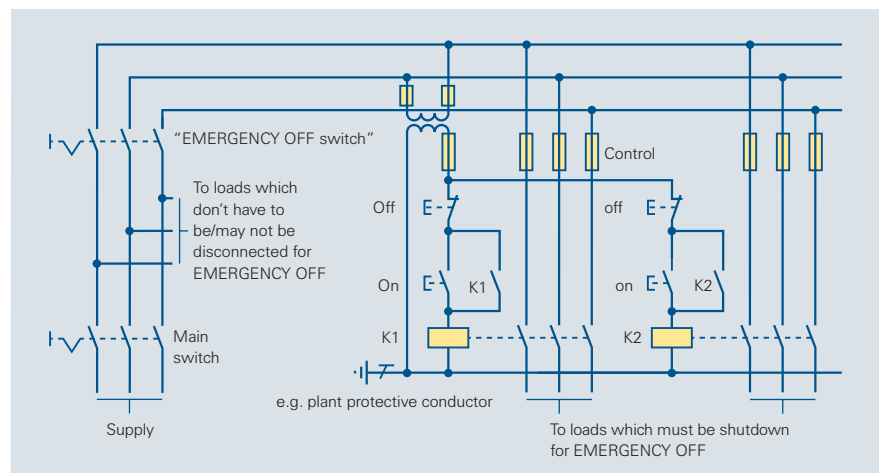

Circuit diagram 6/2
Example of a machine control with EMERGENCY OFF switch (this is only permissible with some restrictions)

Using three auxiliary contactors

Today, circuits with three auxiliary contactors represent state-of-the-art technology. Three auxiliary contactors, with positively-driven contacts are used, as shown in circuit diagram 6/5. The three auxiliary contactors guarantee redundancy and function monitoring. The positively-driven contacts guarantee that the auxiliary contactors mutually monitor themselves. Faults are therefore detected and the circuit can no longer be closed after shut-down, therefore eliminating subsequent faults.

With this circuit, using today's state-of-the-art technology, it can be assumed that if the auxiliary contactors incorrectly function this will not result in a hazardous status in the system.

Several auxiliary contactors are combined to form a safety circuit in the form of the 3TK28 contactor safety combinations. Naturally, the circuits

can also be implemented using individual contactors.

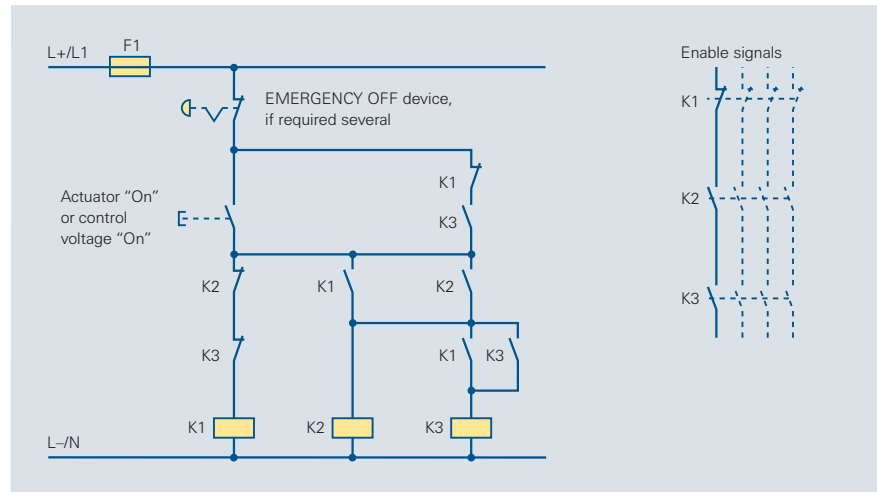

Circuit diagram 6/5
Contactor combination using three auxiliary contactors with self-monitoring, single-channel

Connecting several EMERGENCY OFF control devices

In the previous circuit diagrams, only one EMERGENCY OFF device was shown. Generally, there are several EMERGENCY OFF control devices (e.g. at different locations) on a machine. The contacts of these EMERGENCY OFF control devices are then connected in series.

Circuit examples to monitor protective devices

Circuits to monitor protective devices use position switches. Various possibilities of the different devices are shown in the examples for EMERGENCY OFF. These circuit examples will not be repeated here as the EMERGENCY OFF control device is only replaced by one or two position

switches per protective device. The number of position switches which are required for each protective door can be taken from Section 2 of the Manual.

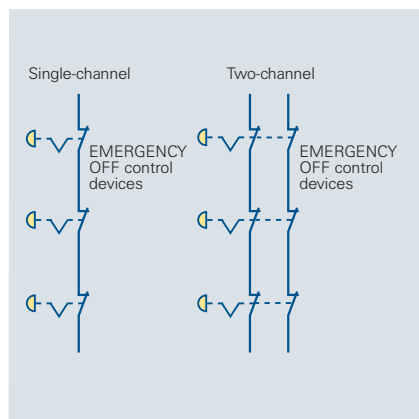

Circuit diagram 6/6
Several EMERGENCY OFF control devices

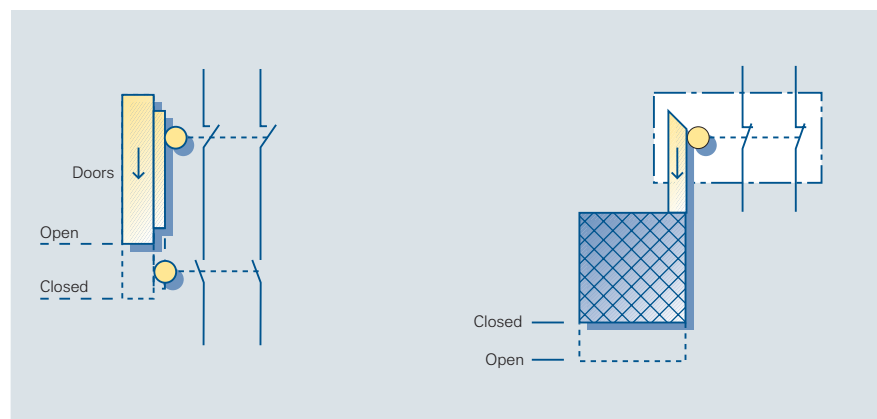

Circuit diagram 6/7
SIGUARD position switches used to monitor moving protective equipment

6.2 3TK28 SIGUARD Contactor Safety Combinations



The internal circuit diagrams are valid for DC-operated devices. The AC-operated SIGUARD combinations essentially correspond to those for DC operation. Only the polarity protection diode V1 is eliminated and a bridge rectifier is located in front of every contactor. This means that AC-operated SIGUARD contactor safety combinations can also be used for DC voltages with some restrictions.

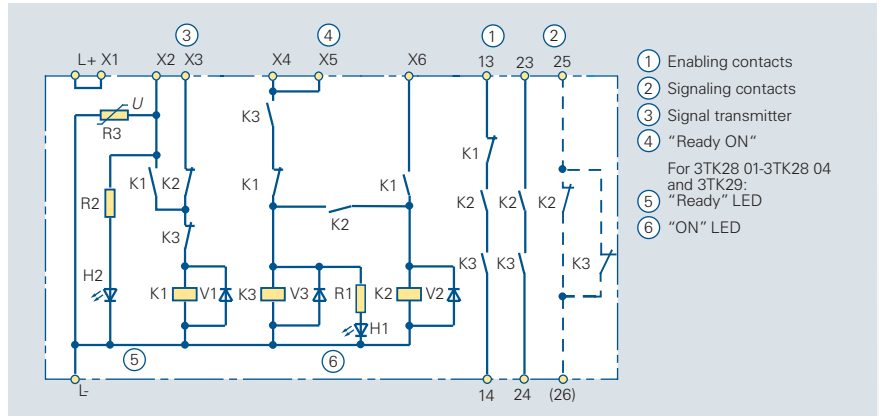

Circuit diagram 6/8
 Internal circuit diagram of 3TK28 01, 3TK28 02 contactor safety combination (DC operation) NC signaling contact for 3TK28 02. For 3TK 2801/02, terminals "X2, X4, X6" are at the top, for TK 2803, there is no terminal "X3"

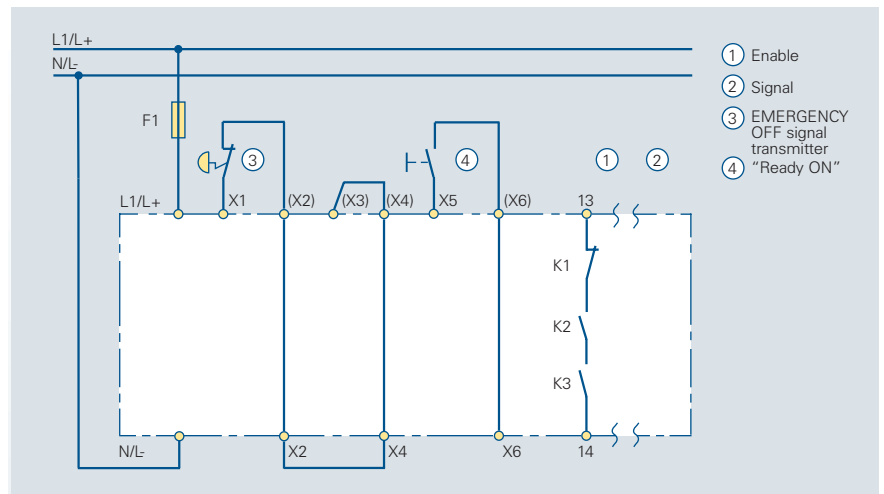

Circuit diagram 6/9
 Contactor safety combinations 3TK28 01 to 3TK2804 for EMERGENCY OFF circuits

Immediately ready after the power returns (it is not necessary to open and close the protective device):

The "Ready ON" ④ is not required (jumper X5-X6), if the resulting automatic reclosure (restart) does not represent potential danger.

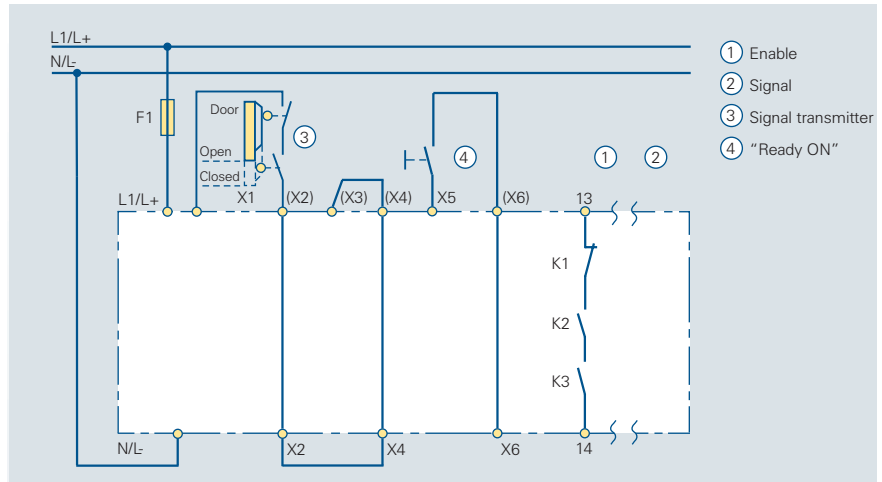

Circuit diagram 6/10

Contactors safety combinations 3TK28 01 to 3TK28 04 to monitor moving protective devices. For 3TK 2801/02, terminals "X2, X4, X6" are at the top, for TK 2803, there is no terminal "X3."

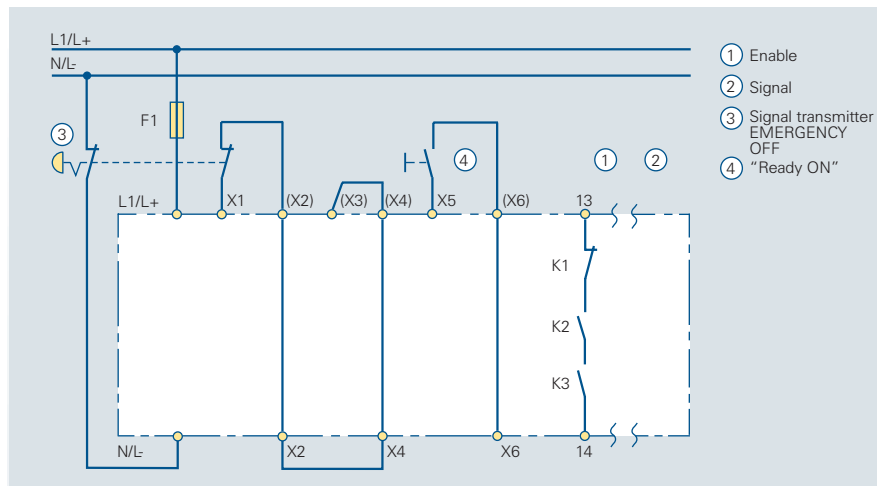

Circuit diagram 6/11

Contactors safety combinations 3TK28 01 to 3TK28 04 for an EMERGENCY OFF circuit. For 3TK28 01/02, terminals "X2, X4, X6" are at the top, for 3TK 2803, there is no terminal "X3."

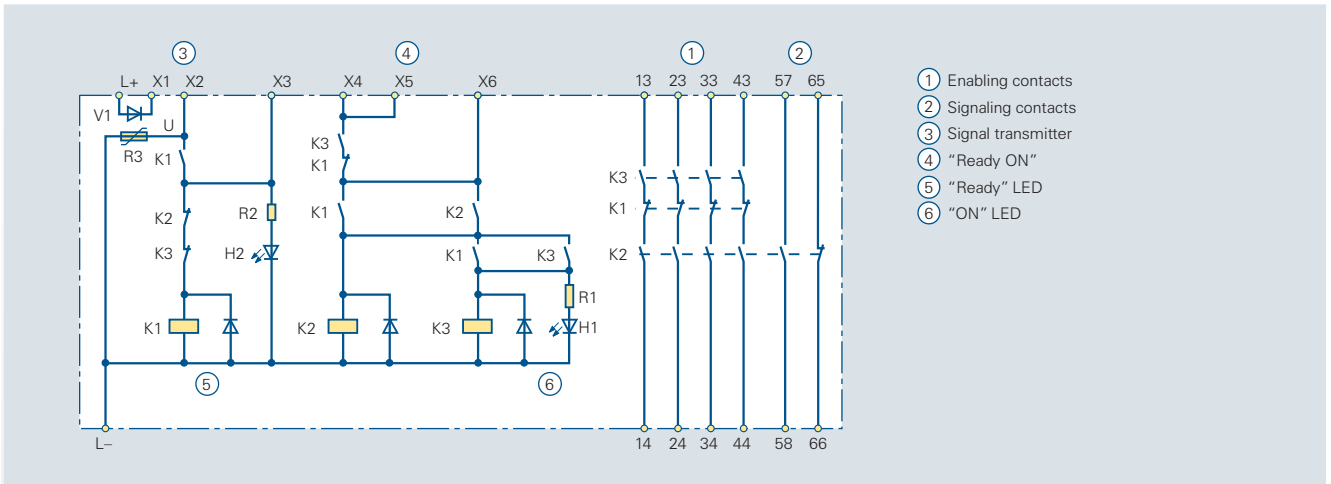

Circuit diagram 6/12
Internal circuit diagram of a 3TK28 04 contactor safety combination (DC operation)

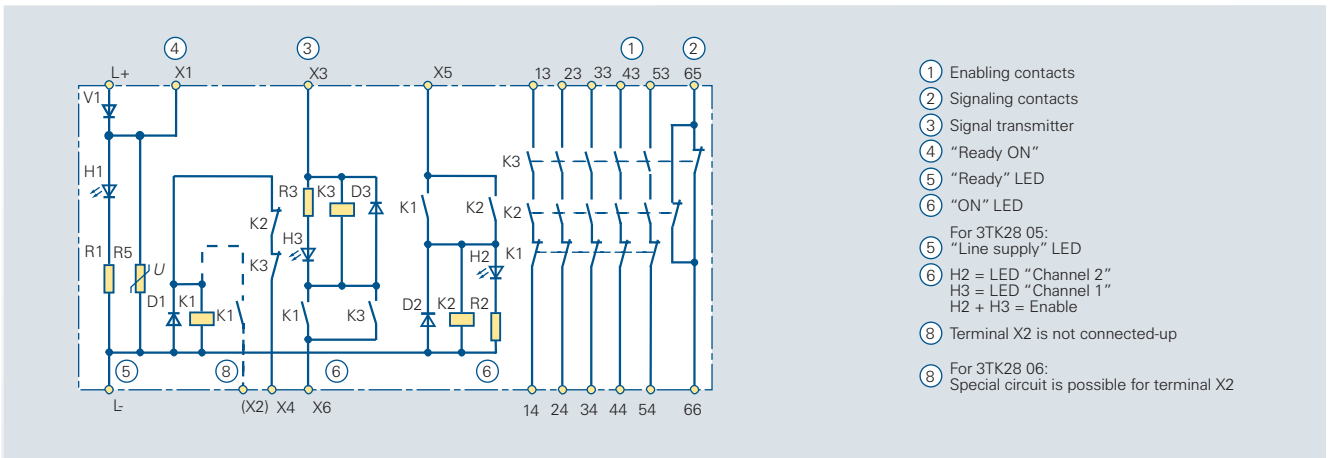

Circuit diagram 6/13
Internal circuit diagram of a 3TK28 05, 3TK28 06 contactor safety combination (DC operation); terminal X2 is only connected-up for the 3TK28 06 device

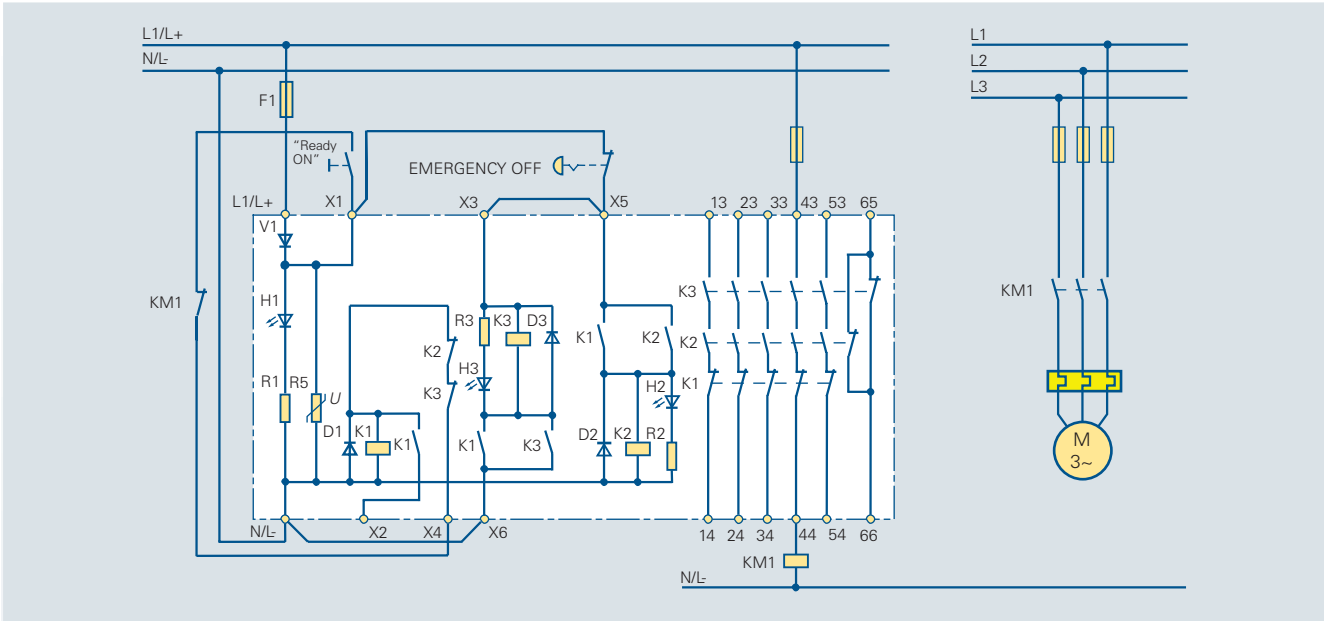

Circuit diagram 6/14
 Contactor safety combination 3TK28 06 for a single-channel EMERGENCY OFF circuit.
 This circuit can also be used for the 3TK28 05 (Cat. 2).

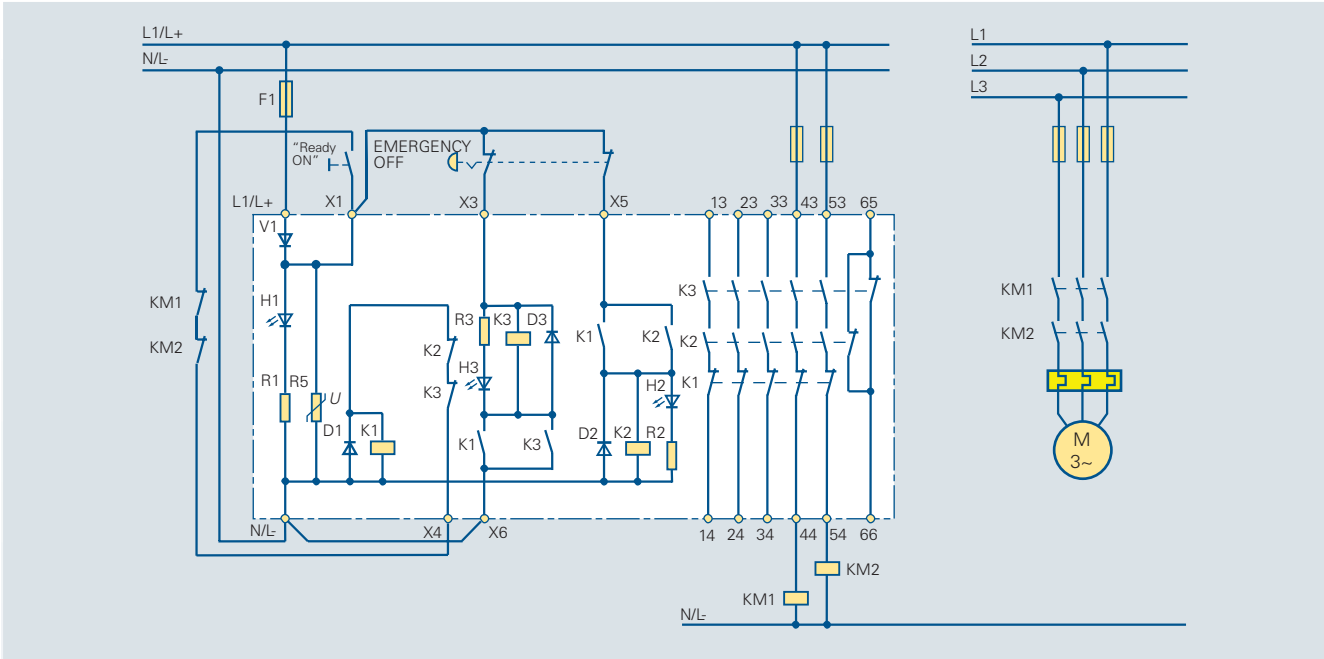

Circuit diagram 6/15
 Contactor safety combination 3TK28 06 for a two-channel EMERGENCY OFF circuit.
 This circuit can also be used for the 3TK28 05 (Cat. 3).

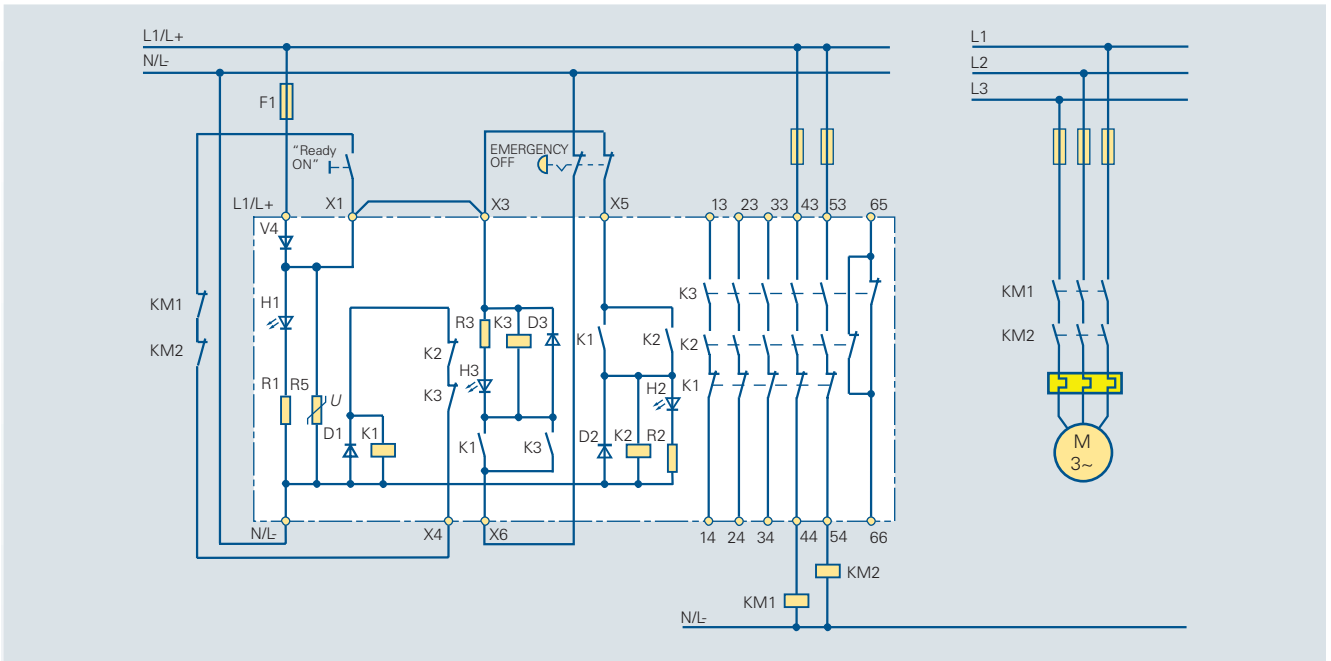

Circuit diagram 6/16
 Contactor safety combination 3TK28 06 for a two-channel EMERGENCY OFF circuit with cross-circuit protection.
 This circuit can also be used for the 3TK28 05 (Cat. 4).

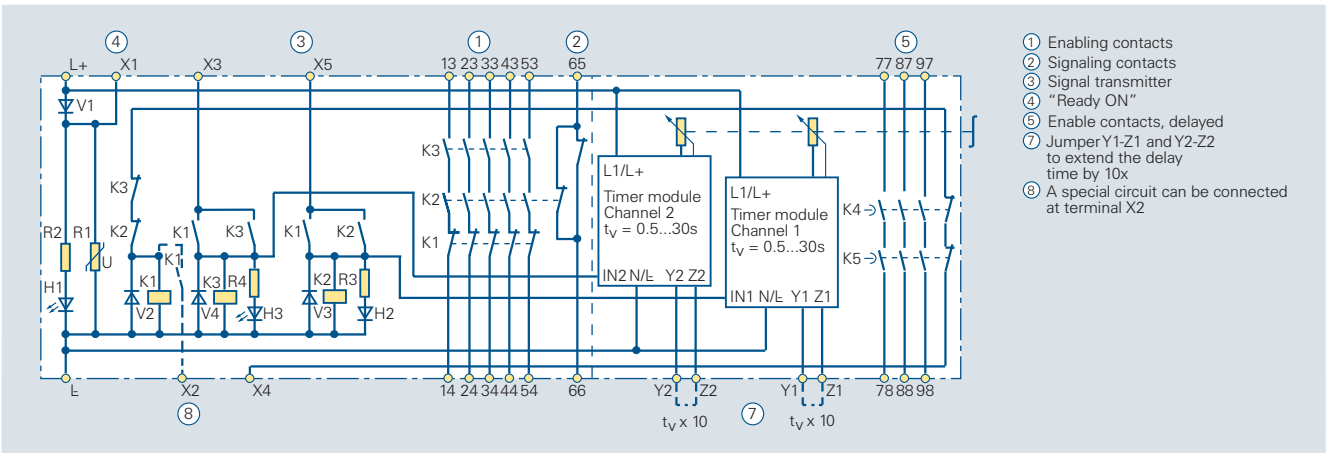

Circuit diagram 6/17
 Internal circuit diagram of a 3TK28 07 contactor safety combination (DC operation)

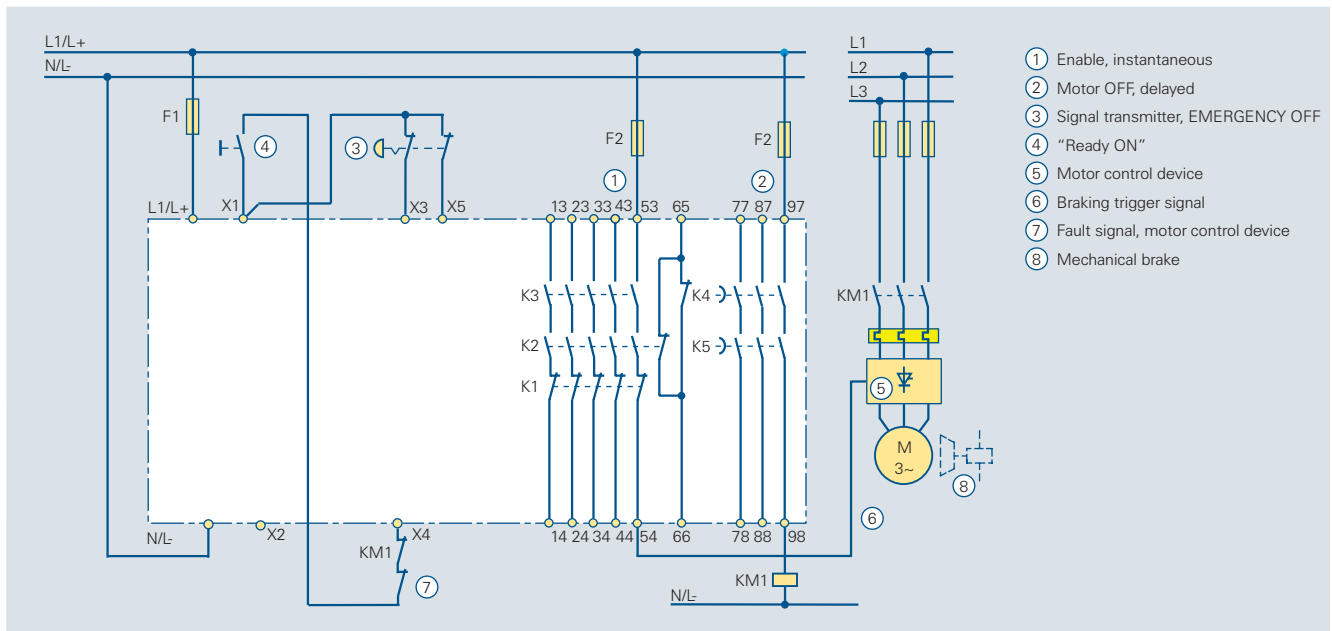

Circuit diagram 6/18
 Contactor safety combination 3TK28 07 for controlled actuation of EMERGENCY OFF.

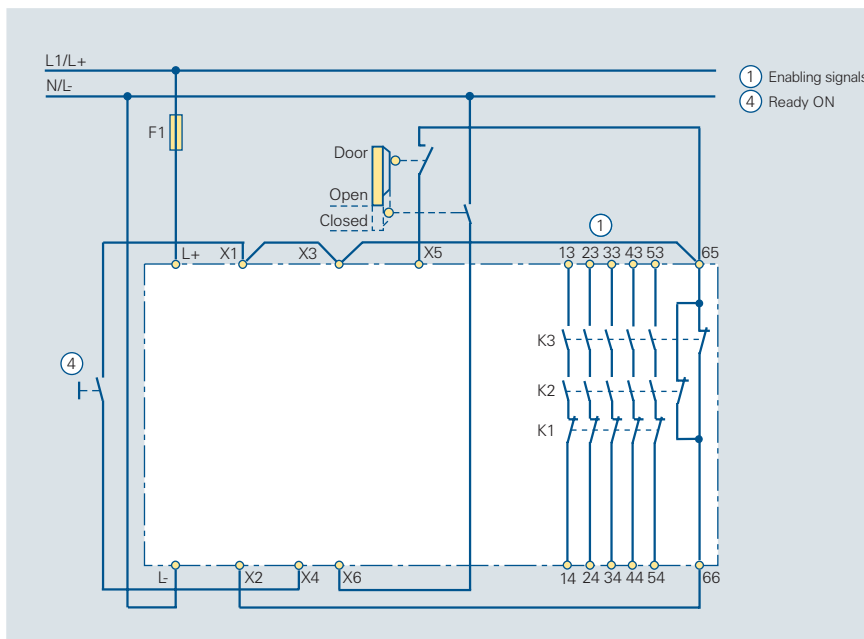

Circuit diagram 6/19
 Contactor safety combination 3TK28 06 to monitor moving protective devices

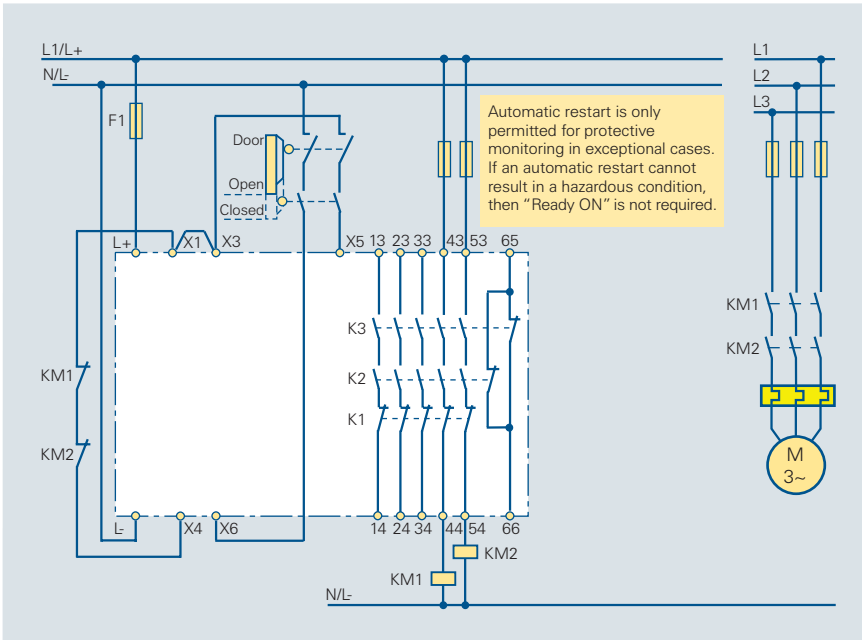

Circuit diagram 6/20
 Contactor safety combination 3TK28 06 for two-channel and cross-circuit proof monitoring of moving protective devices with automatic restart

Classification in Categories according to EN 954-1

The classification of circuits into categories according to EN 954-1 has now been made clear using the previous examples.

The classification below, is valid when the wiring is correctly realized according to the published circuit diagrams, also under difficult ambient conditions, for example dirty industrial environments (pollution level 3).

If special care is taken connecting-up the wiring, it may be possible to achieve a higher safety category, e.g.

using separate cables or routing the cable to EMERGENCY OFF contacts and position switches so that it is mechanically protected (e.g. in special cable ducts). Thus, Category 4 can be achieved without having a cross-circuit proof configuration, under the assumption, that the appropriate peripheral devices are used.

Category acc. to EN 954-1	Circuit version	Possible equipment
B, 1, 2	Single channel	Possible with all basic- and expansion devices
3	Two channel	3TK2805, 3TK28 06, 3TK28 07, also in conjunction with one or several expansion units
4	Two channel and cross-circuit proof	3TK28 05 and 3TK2806 also in conjunction with one or several expansion units

Interface for expansion units

The 3TK29 SIGUARD combination expansion units must always be used together with a basic 3TK28 unit. One expansion unit can be connected for each enabling contact in the basic unit. The signaling contact in the expansion unit must always be connected in series with "Ready ON."

The Category which a circuit with an expansion unit can achieve according to EN 954-1 depends on the Category of the basic unit with interface. If the expansion unit is located next to the basic unit in the cabinet, the connecting cables between the basic unit and expansion unit are so short, that a fault (electrical fault) can be completely ruled-out in these connecting cables.

A circuit with the 3TK28 06 and two expansion units to multiply the contacts of the 3TK28 07 is illustrated in circuit diagram 6/21.

The 3TK29 . 3 expansion units can be used for drop-out delayed contacts of up to 8 seconds (circuit diagram 6/23). The delay time is set using different jumpers at connecting terminals Y2, Z1, Z2 and Z3.

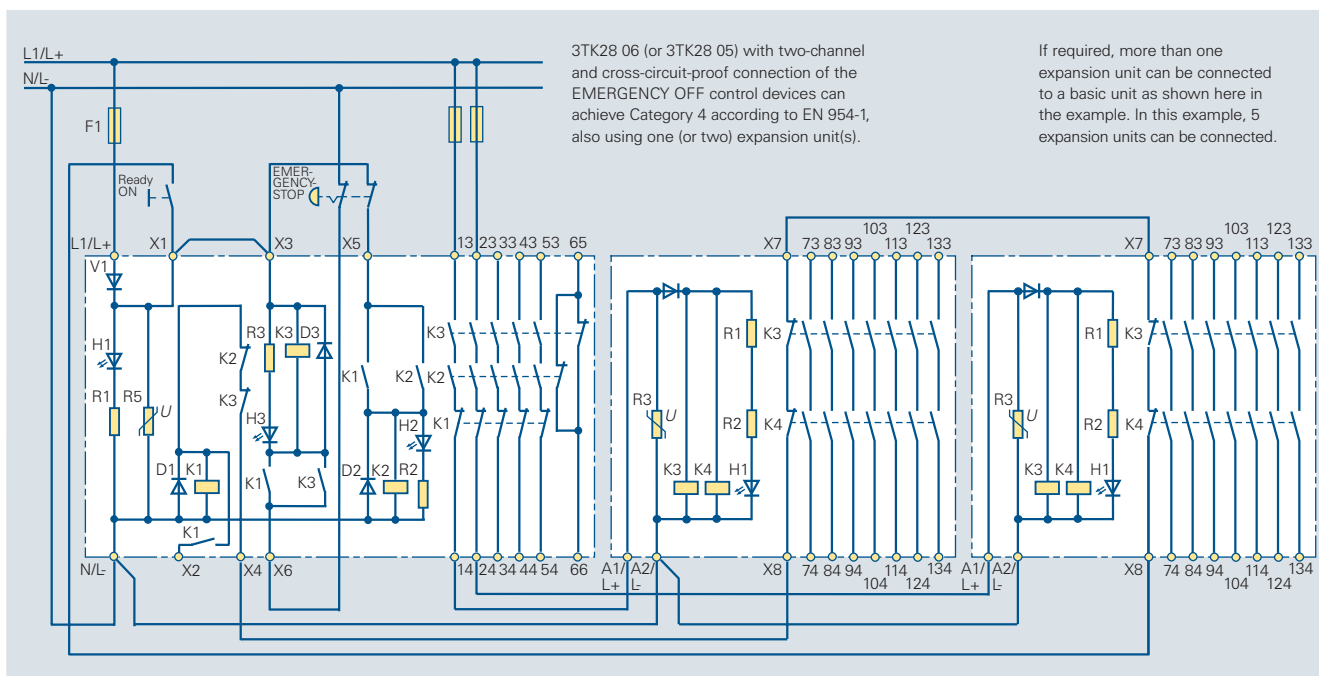

Circuit diagram 6/21
 Contactor safety combinations 3TK28 06 for two-channel and cross-circuit-proof connection of the EMERGENCY OFF control device and two 3TK29 07 expansion units. This circuit can also be realized using the 3TK28 05 unit.

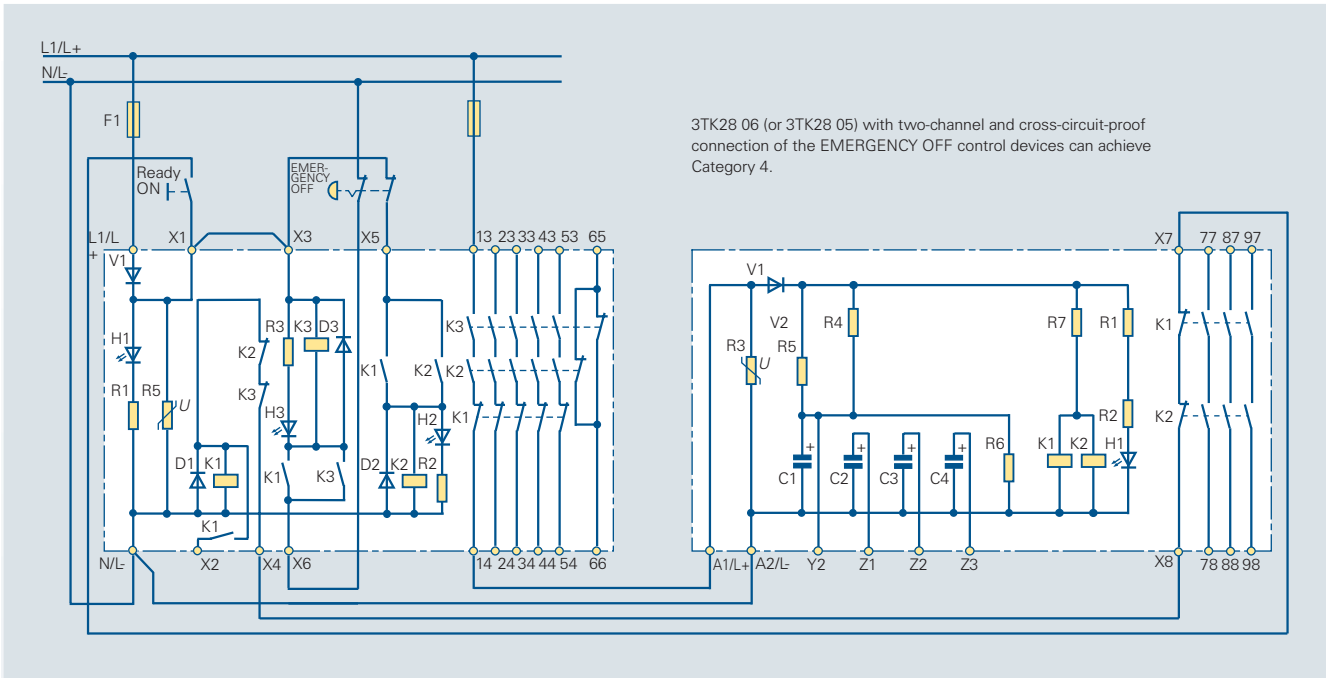

3TK28 06 (or 3TK28 05) with two-channel and cross-circuit-proof connection of the EMERGENCY OFF control devices can achieve Category 4.

Circuit diagram 6/22
 Contactor safety combination 3TK28 06 for two-channel and cross-circuit-proof connection of the EMERGENCY OFF control device and a 3TK29 . 3 expansion unit.
 This circuit can also be used with the 3TK28 05.

Expansion units

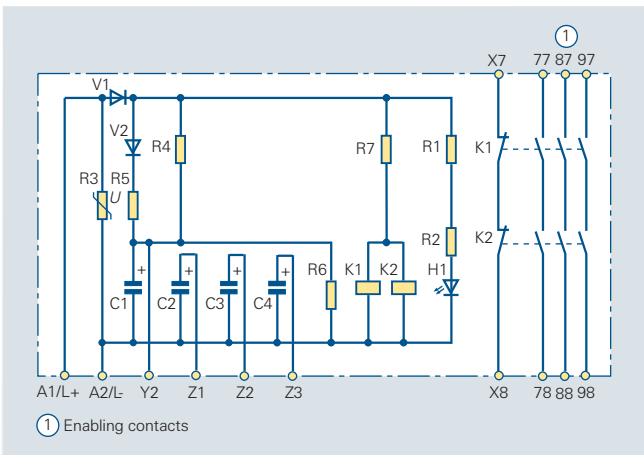

Circuit diagram 6/23
 Internal circuit diagram of a contactor safety combination delay module 3TK29 23, 43, 83 (DC operation)

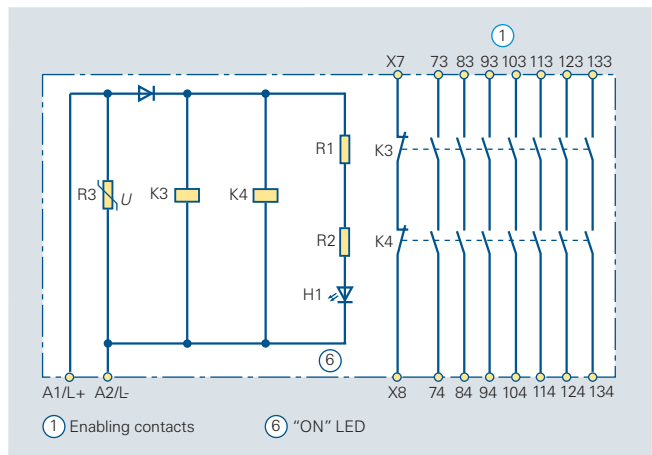

Circuit diagram 6/24
 Internal circuit diagram of a contactor safety combination supplementary module 3TK29 07 (DC operation)

Press control devices

Circuit examples for presses

The two devices, two-hand control device 3TK28 11 and overtravel tester 3TK28 15 are used for press controls.

Two-hand control device 3TK28 11

The two-hand control device 3TK28 11 is a control which allows presses to be controlled using two hands. For presses, it must be ensured that both hands are required to control the presses.

The two-hand control device fulfills Category 4 in accordance with EN 954-1 and achieves type 3 according to EN 60 204-1 (VDE 0113 Part 1) as well as type IIIc according to EN 574 for two-hand control systems. This means that both control devices of the 3SB33 SIGUARD two-hand control must be simultaneously actuated (≤ 0.5 s) with both hands and they have to be continually actuated while the press is in a hazardous condition.

If one actuator device is released, then the control stops the hazardous motion. If the 0.5 s is exceeded, or if one of the control devices is released, then both control devices must be released before a restart can be initiated.

It should also be observed that the switching currents for the control devices are 50 mA at 24 V DC. The 3SB3 SIGNUM[®] control devices, as well as the SIGUARD two-hand operator unit 3SB33G3 are suitable. It may be necessary to use gold-plated contacts.

Control interlocking functions are switched in the feedback circuit.

3TK28 15 overtravel tester

This unit is used to check overtravel for linearly operated presses, such as spindle, hydraulic and pneumatic presses.

Each time that the power supply is switched-on at the two-hand control device 3TK28 11, the braking travel is checked using the 3TK28 15.

3TK28 15 must always be used in conjunction with the two-hand control unit 3TK28 11.

For press control units using relays, refer to Pages 6/28 to 6/31.

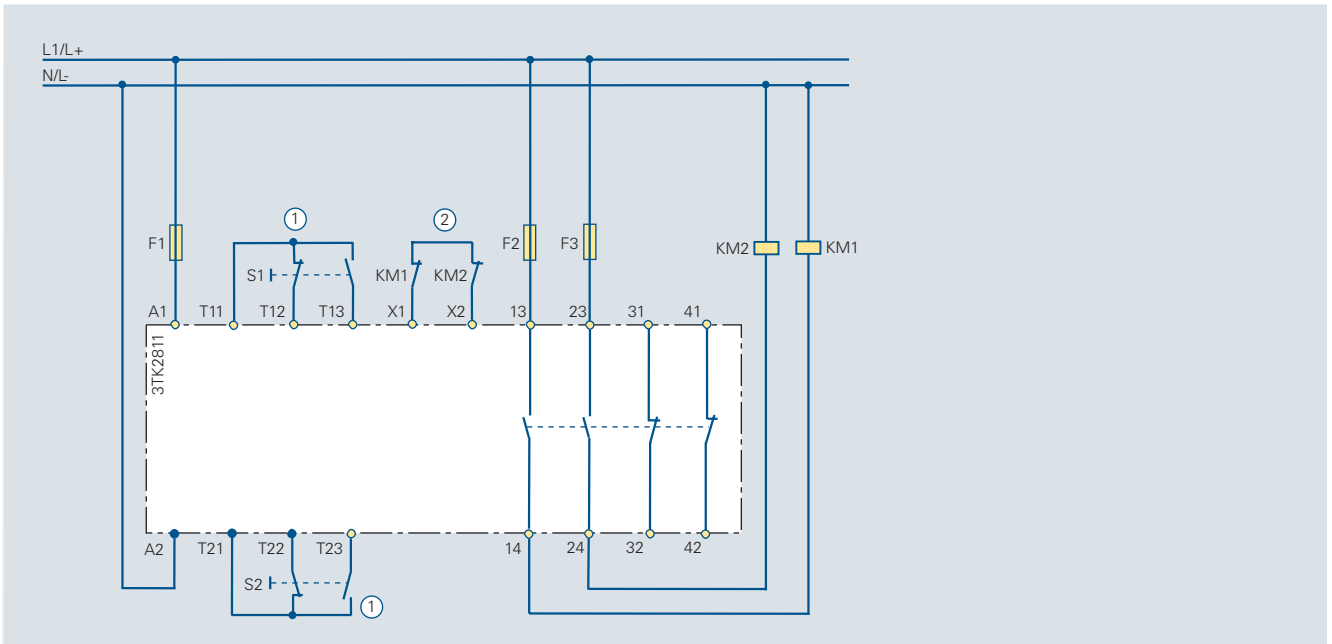

Circuit diagram 6/25
Two-hand control device 3TK28 11

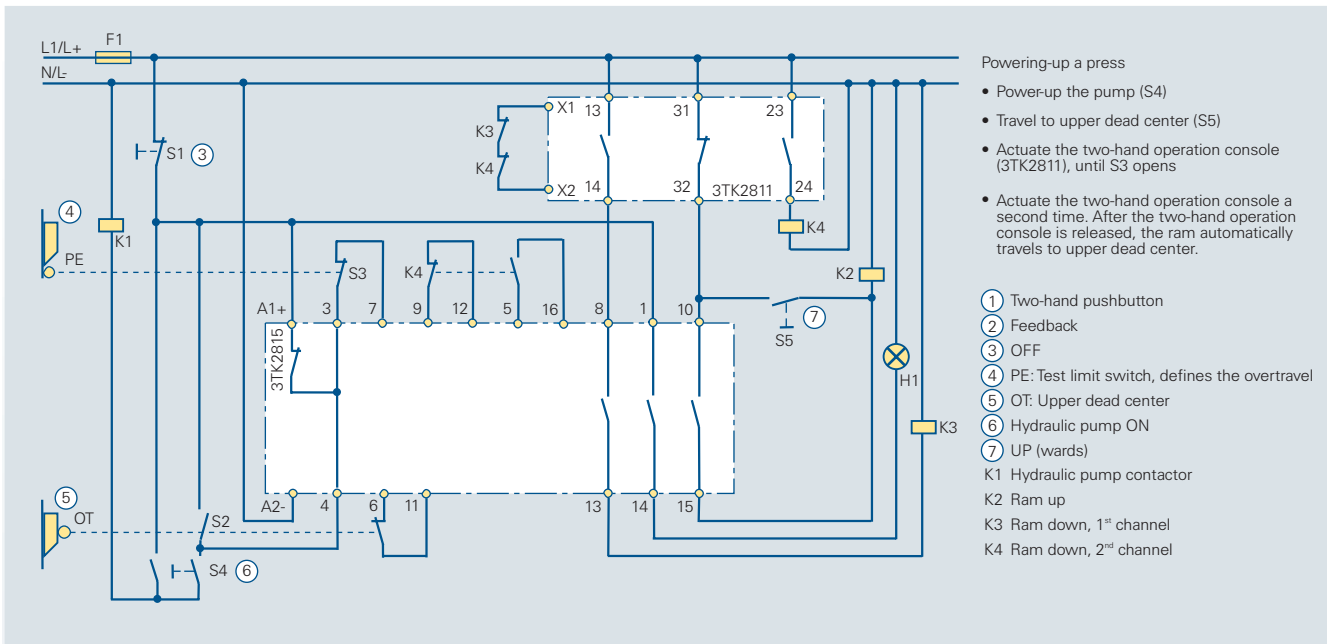

- Powering-up a press
- Power-up the pump (S4)
 - Travel to upper dead center (S5)
 - Actuate the two-hand operation console (3TK2811), until S3 opens
 - Actuate the two-hand operation console a second time. After the two-hand operation console is released, the ram automatically travels to upper dead center.
- ① Two-hand pushbutton
 - ② Feedback
 - ③ OFF
 - ④ PE: Test limit switch, defines the overtravel
 - ⑤ OT: Upper dead center
 - ⑥ Hydraulic pump ON
 - ⑦ UP (wards)
 - K1 Hydraulic pump contactor
 - K2 Ram up
 - K3 Ram down, 1st channel
 - K4 Ram down, 2nd channel

Circuit diagram 6/26
Overtravel tester 3TK28 15 and two-hand control device 3TK28 11

6.3 3TK28 SIGUARD Relay Safety Combinations

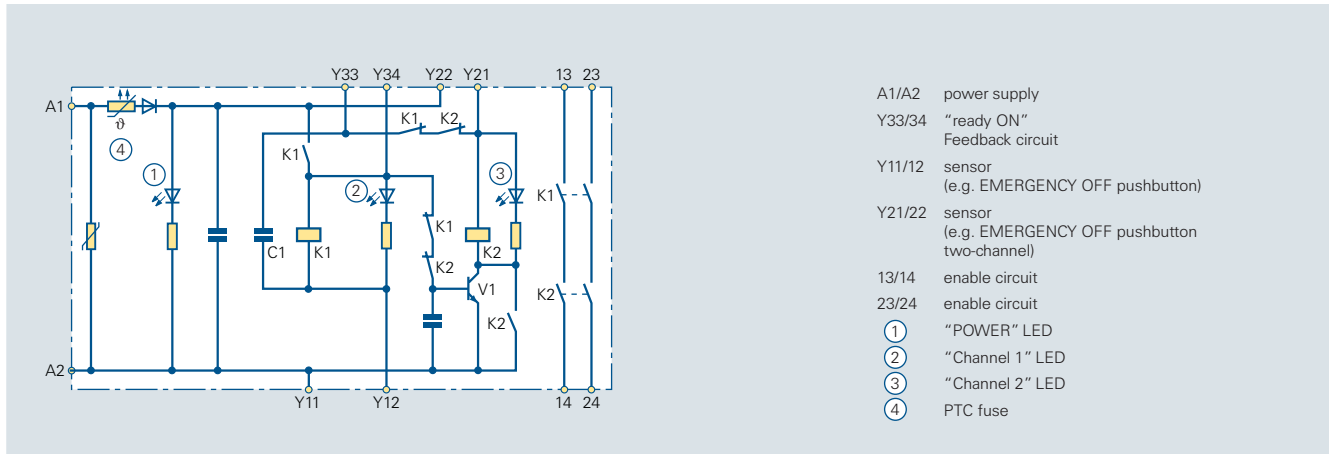

Circuit diagram 6/27
 Internal circuit diagram of the 3TK2823

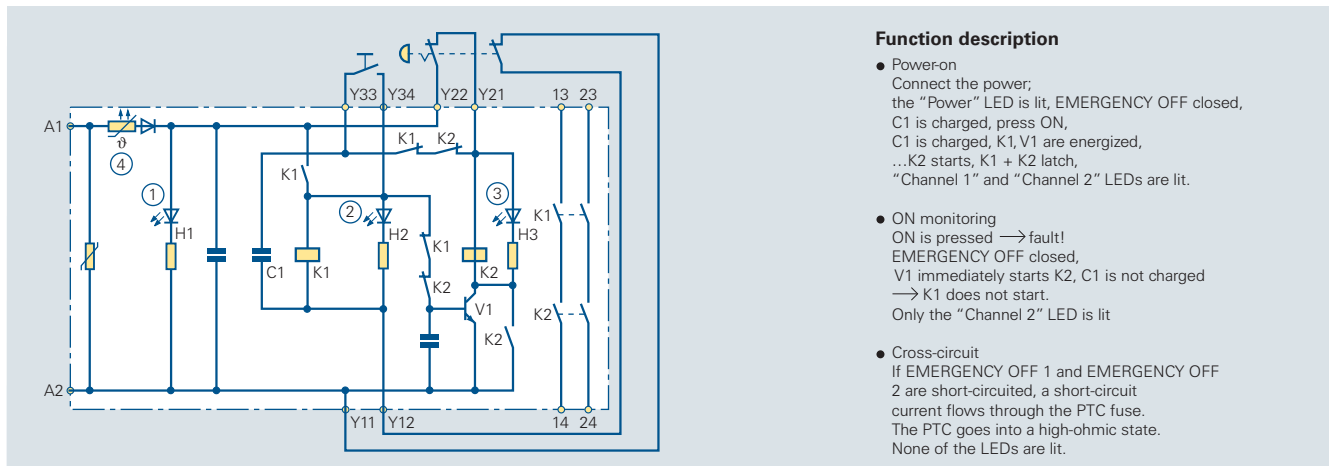

Circuit diagram 6/28
 Function description 3TK2823

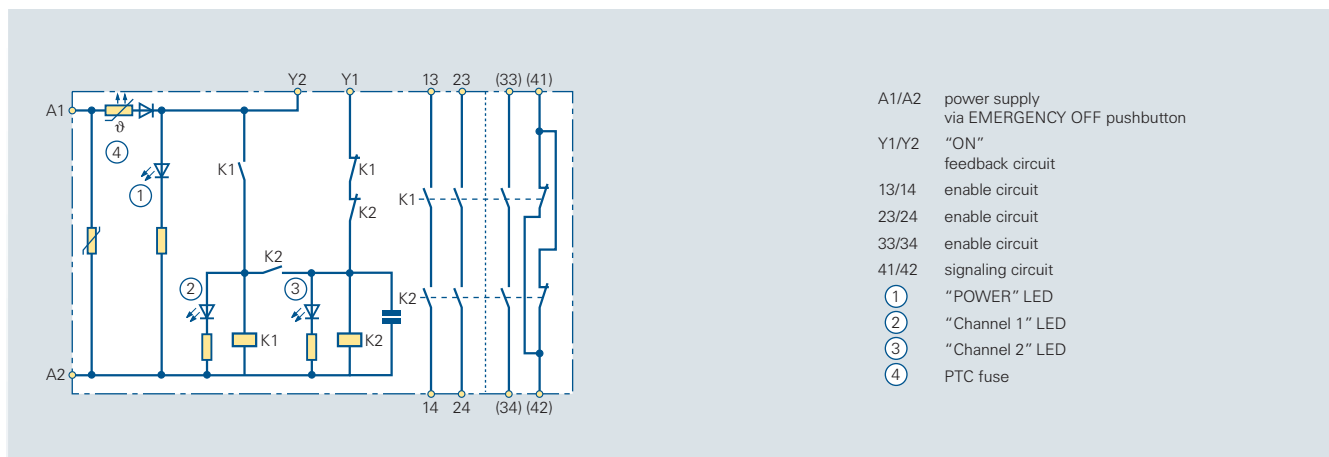

Circuit diagram 6/29
 Internal circuit diagram of the 3TK2821/24

The following circuit diagrams have been harmonized with the German Trade Association (BG) and also approved.

6.3.1 EMERGENCY OFF (EMERGENCY-STOP) circuits

Circuit diagrams

Circuit diagram 6/30
3TK2821/24 for EMERGENCY OFF,
Category 2, single-channel,
with feedback circuit

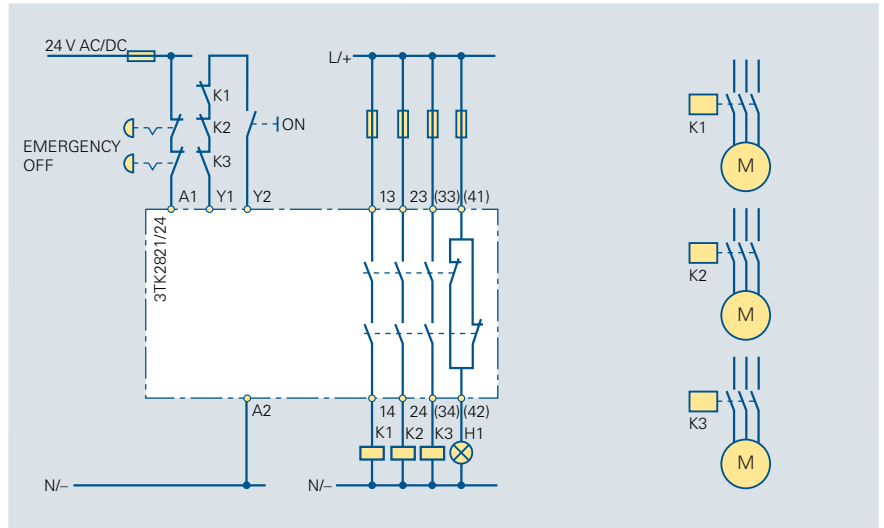

Circuit diagram 6/31
3TK2821/24 for EMERGENCY OFF,
Category 3 (4), two-channel,
with feedback circuit

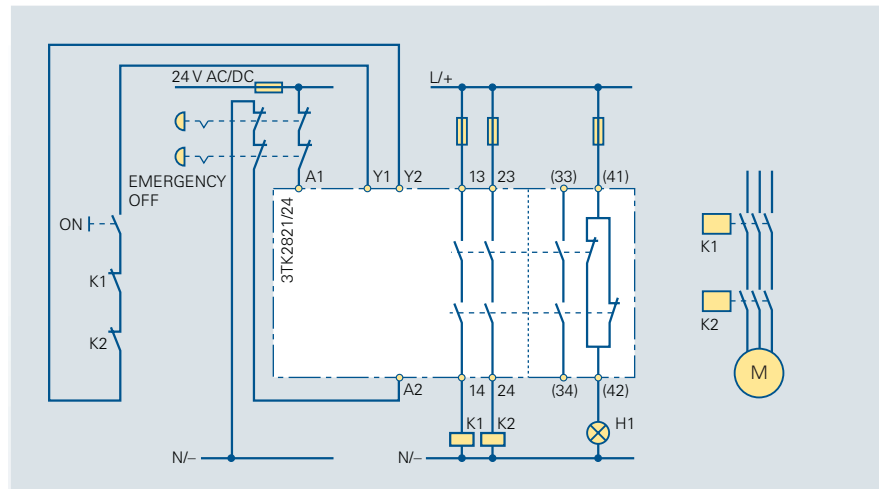

Circuit diagram 6/32
3TK2823 for EMERGENCY OFF,
Category 4, two-channel,
with feedback circuit, monitored start

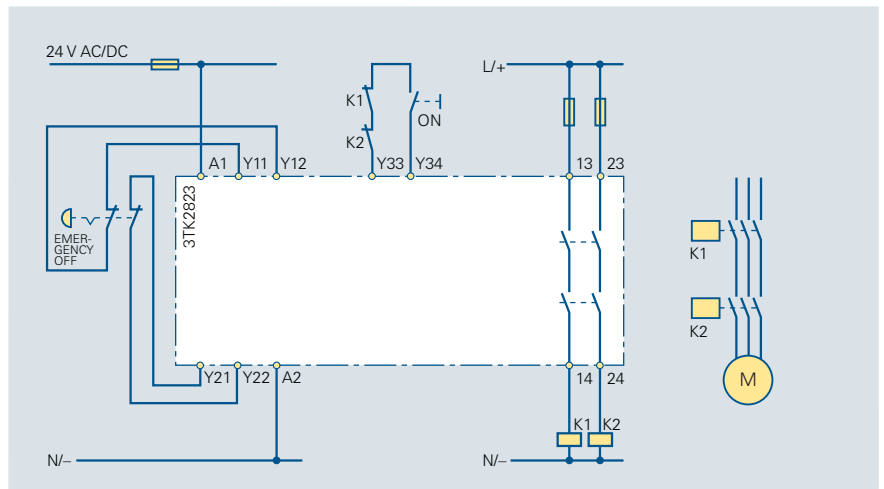

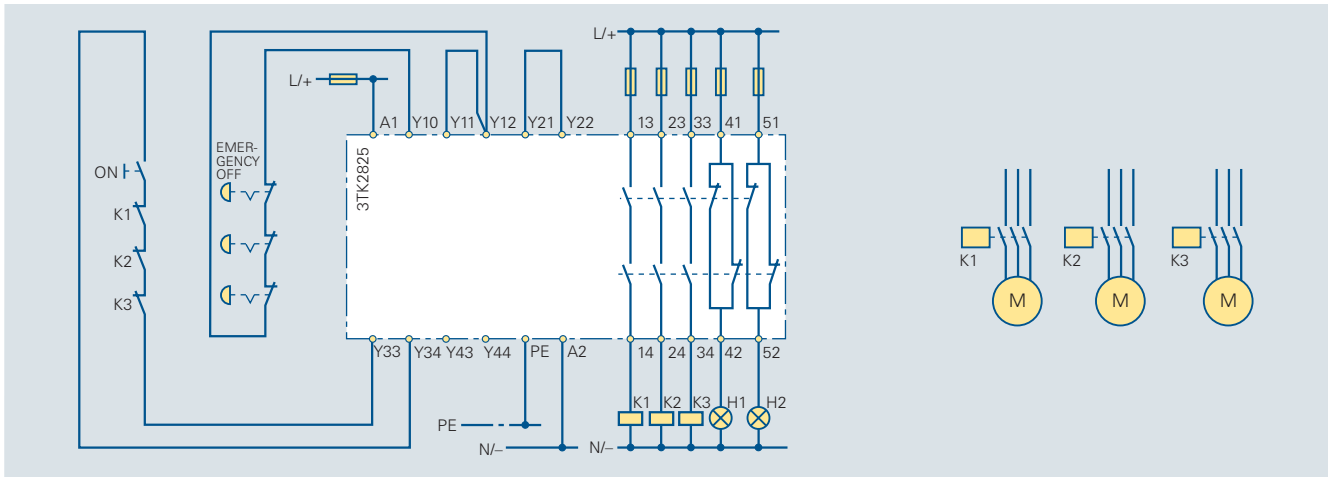

Circuit diagram 6/33 3TK2825 EMERGENCY OFF, Category 2, single-channel, according to EN 954-1, monitored start

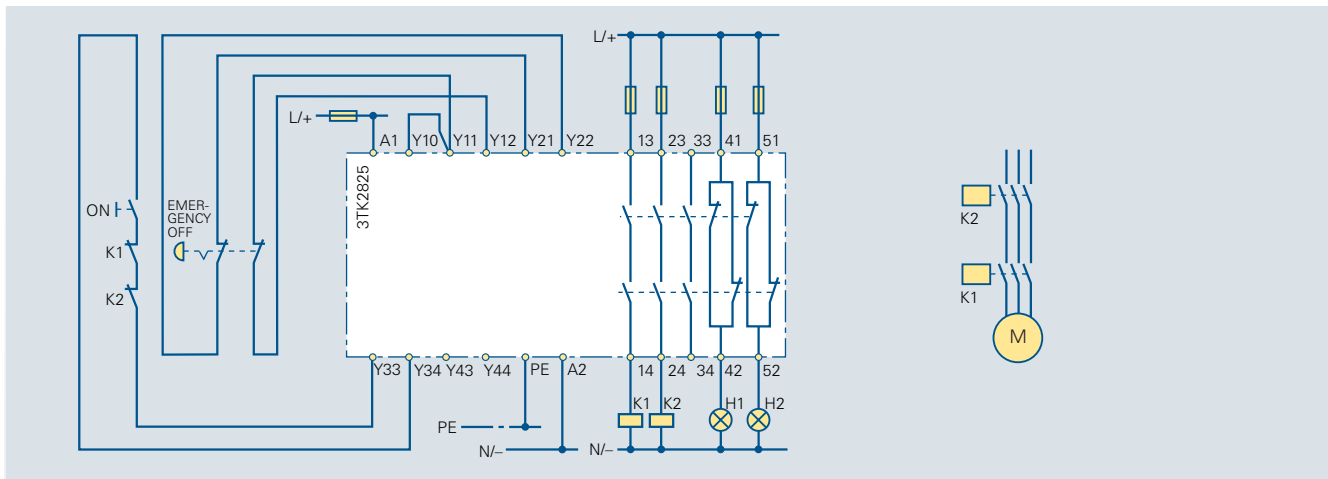

Circuit diagram 6/34 3TK2825 EMERGENCY OFF, Category 4, two-channel, according to EN 954-1, monitored start

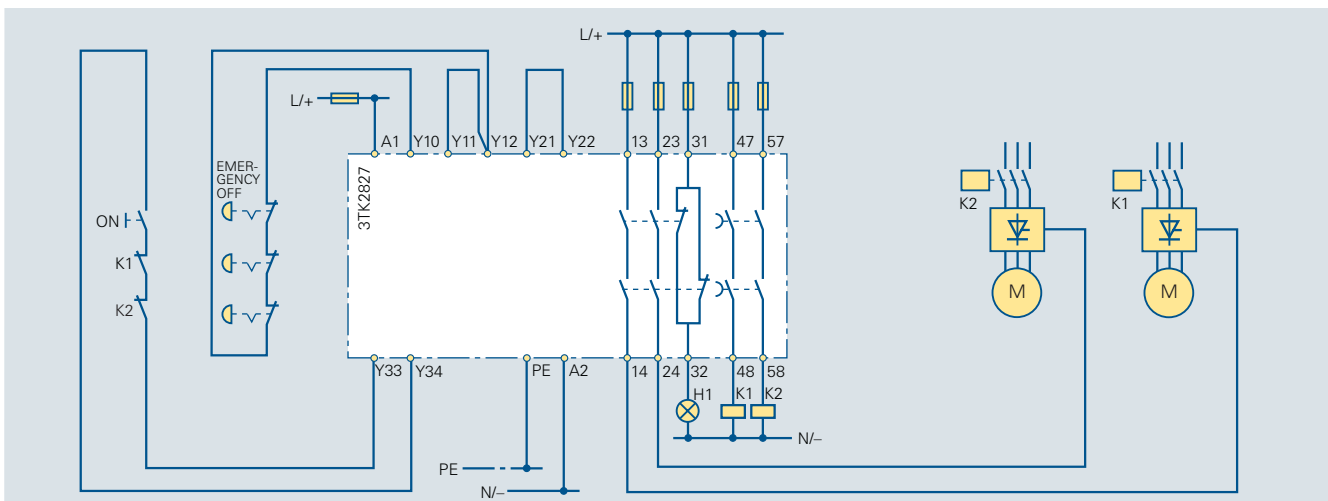

Circuit diagram 6/35 3TK2827 EMERGENCY OFF, Category 2, single-channel, according to EN 954-1, monitored start

Circuit diagram 6/36
 3TK2827 EMERGENCY OFF with shut-down, stop Category 1, for Category 3 according to EN 954-1, two-channel, with feedback circuit, monitored start

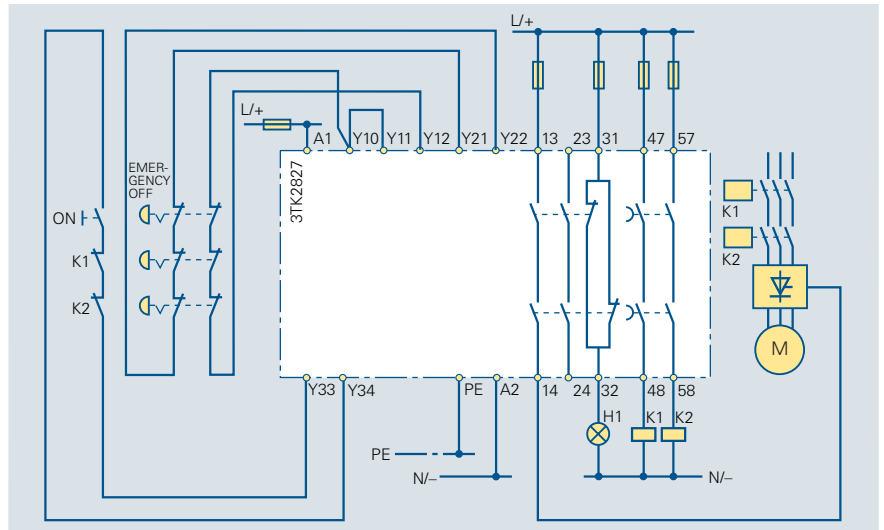

Circuit diagram 6/37
 3TK2823 expanded with 3TK2830 for EMERGENCY OFF, Category 4 acc. to EN 954-1, two-channel, with feedback circuit

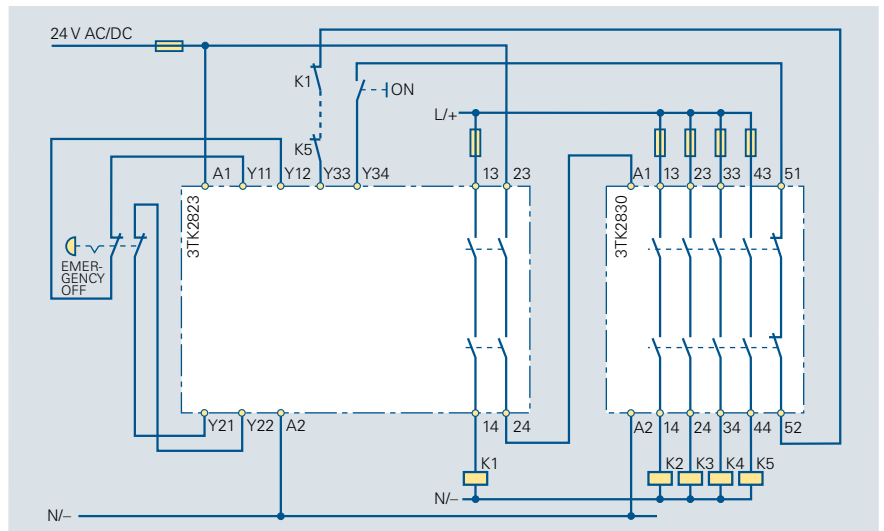

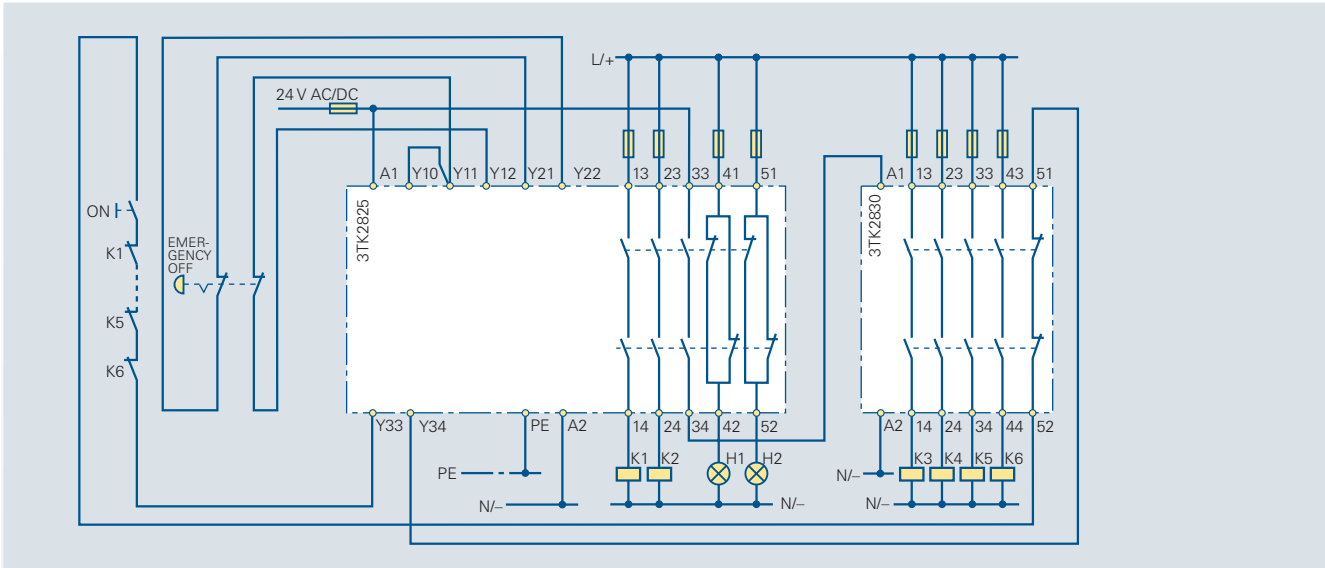

Circuit diagram 6/38
 3TK2825 expanded by 3TK2830 for EMERGENCY OFF, Category 4 acc. to EN 954-1, two-channel acc. to EN 954-1, monitored start

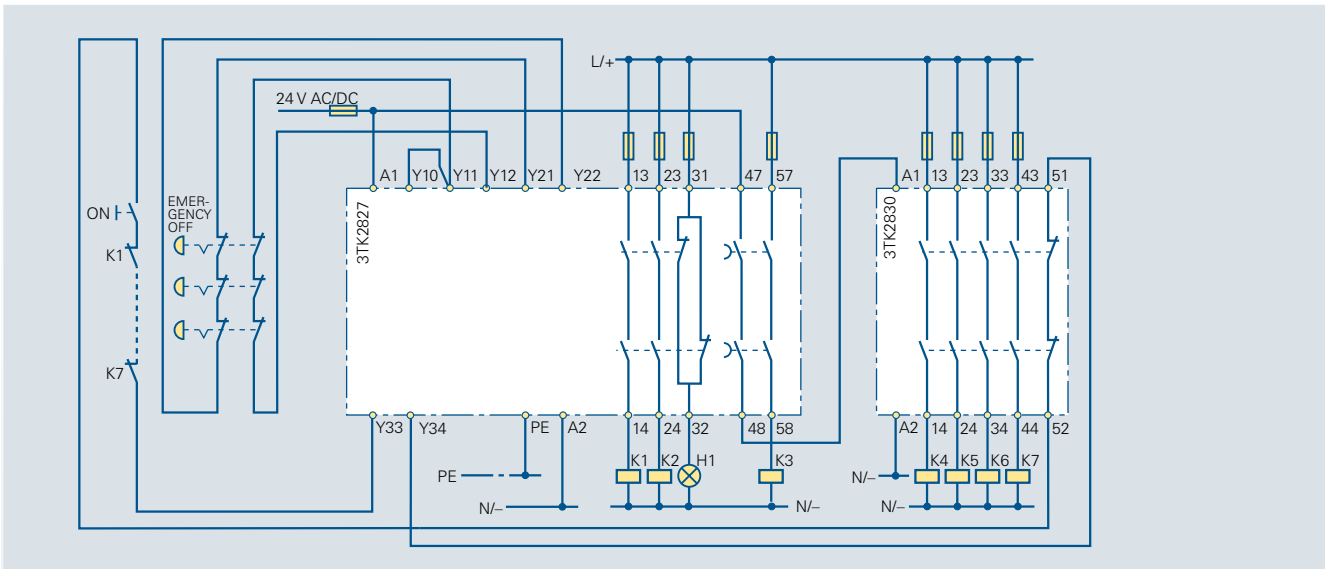

Circuit diagram 6/39
 3TK2827 expanded by 3TK2830 for EMERGENCY OFF, Category 4, two-channel, monitored start

6.3.2 Protective door monitoring

Circuit diagram 6/40
 3TK2821/24 for protective door monitoring
 (2 protective doors are cascaded, each with
 1 SIGUARD position switch), Category 2
 acc. to EN 954-1, single-channel, with
 feedback circuit, autostart

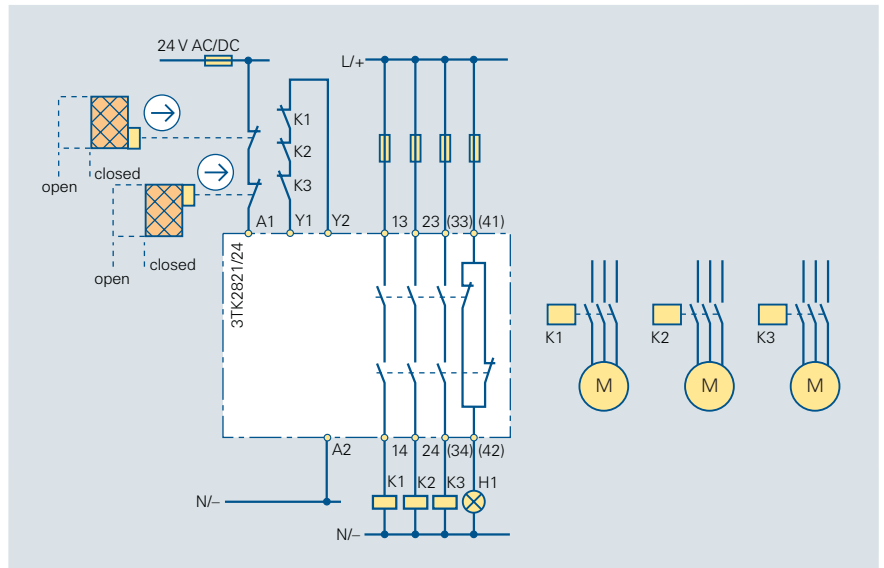

Circuit diagram 6/41
 3TK2821/24 for protective door monitoring
 with tumbler (2 protective doors are
 cascaded, each with 2 SIGUARD position
 switches with tumbler), Category 2 acc.
 to EN 954-1, single-channel, with feedback
 circuit, autostart

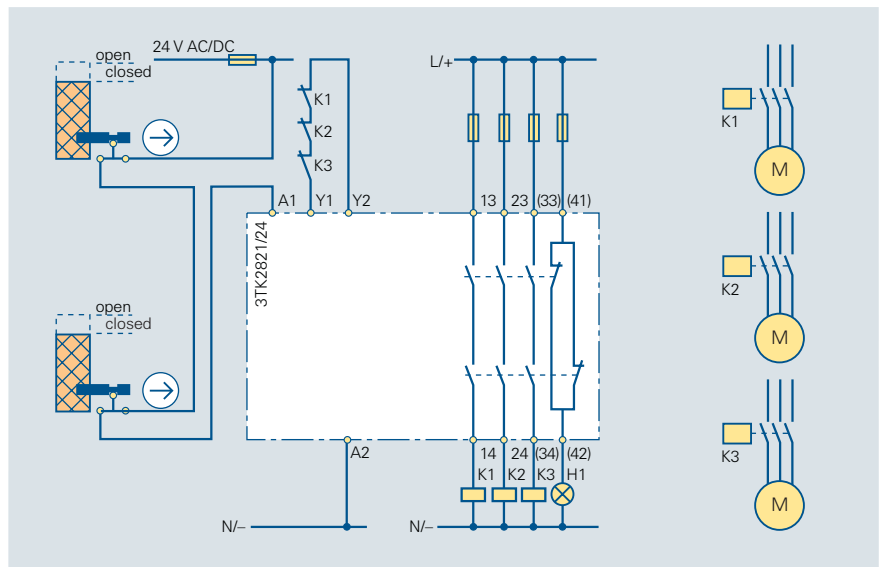

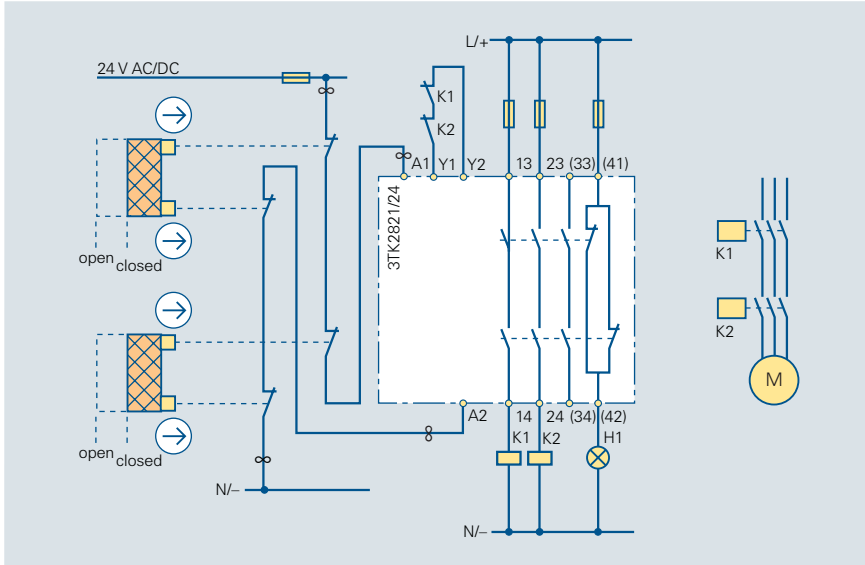

Circuit diagram 6/42
 3TK2821/24 for protective door monitoring
 (2 protective doors are cascaded, each with
 2 SIGUARD position switches), Category
 3(4) acc. to EN 954-1, two-channel with
 feedback circuit, autostart, ∞ for Category 4
 – the cable has to be routed so that it is
 especially protected)

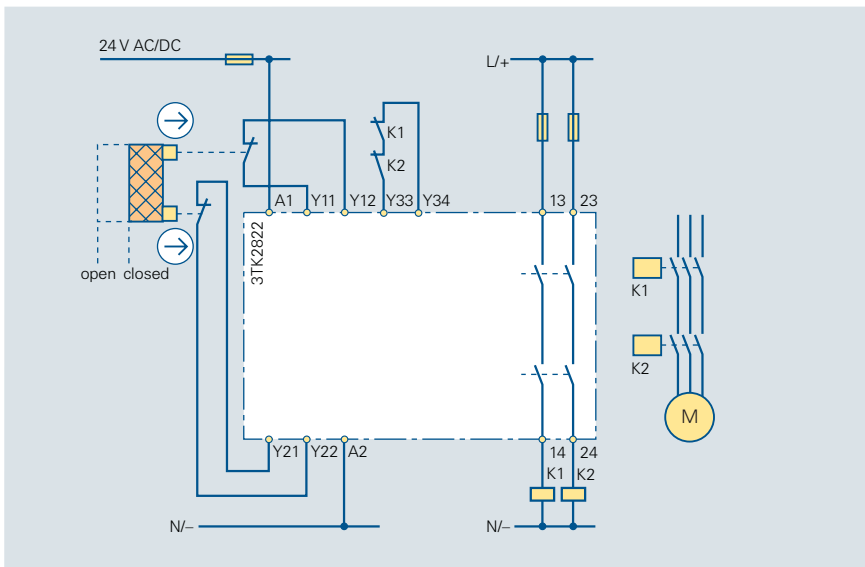

Circuit diagram 6/43
 3TK2822 for protective door monitoring
 (2 protective doors are cascaded, each with
 1 SIGUARD position switch), Category 4
 acc. to EN 954-1, two-channel with
 feedback circuit, autostart

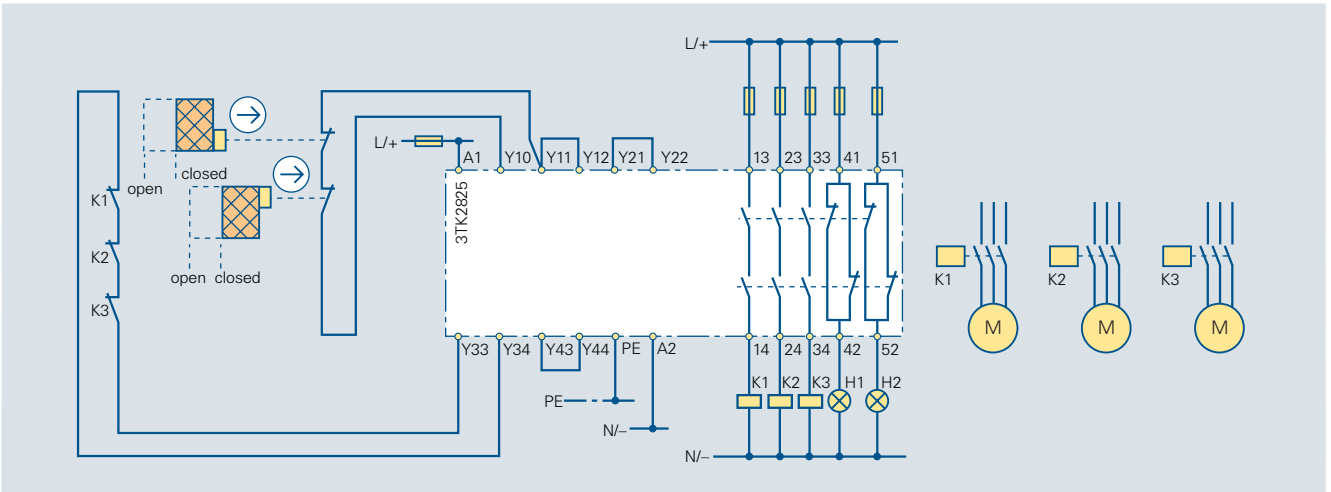

Circuit diagram 6/44
 3TK2825 for protective door monitoring (2 protective doors are cascaded, each with 1 SIGUARD position switch),
 autostart, Category 2 acc. to EN 954-1, single-channel, with feedback circuit

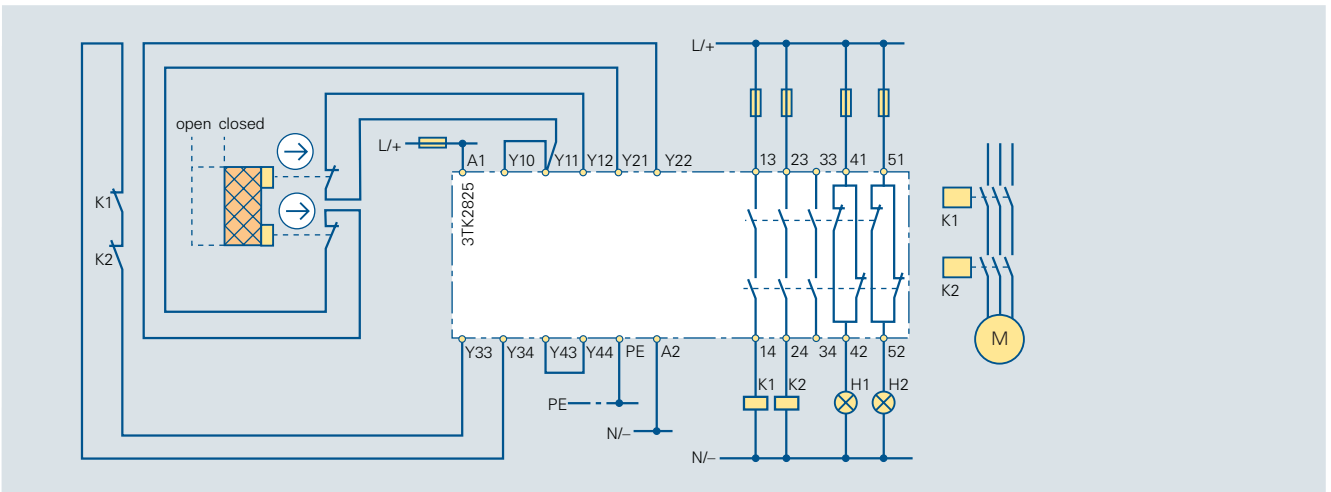

Circuit diagram 6/45
 3TK2825 for protective door monitoring with 2 SIGUARD position switches, autostart, Category 4 acc. to EN 954-1,
 two-channel, with feedback circuit

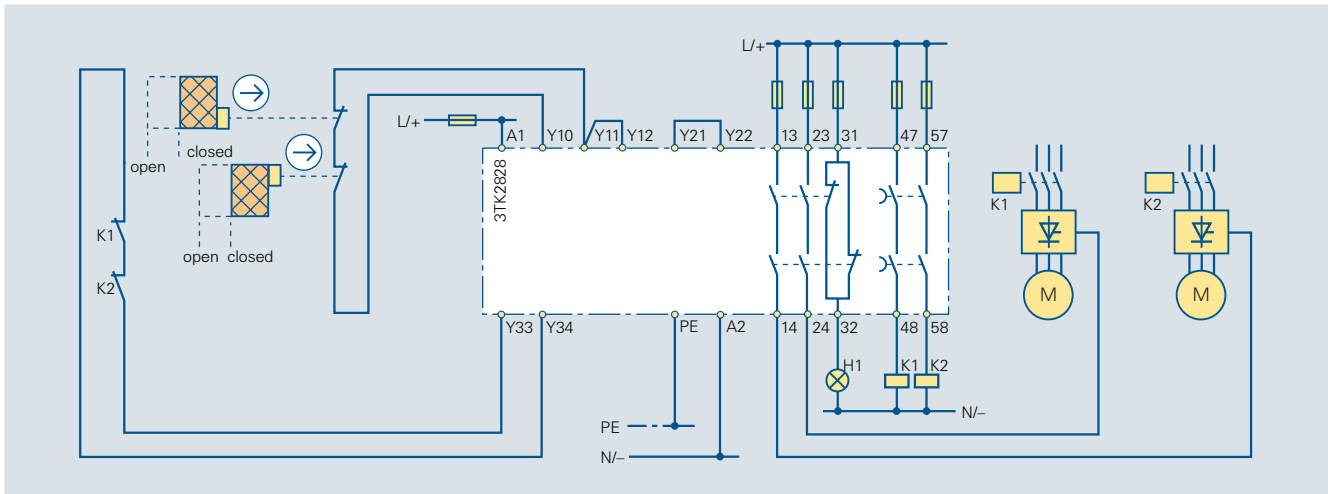

Circuit diagram 6/46
 3TK2828 for protective door monitoring (2 protective doors are cascaded, each with 1 SIGUARD position switch), stop Category 1, Category 2 acc. to EN 954-1, single-channel, with feedback circuit, autostart

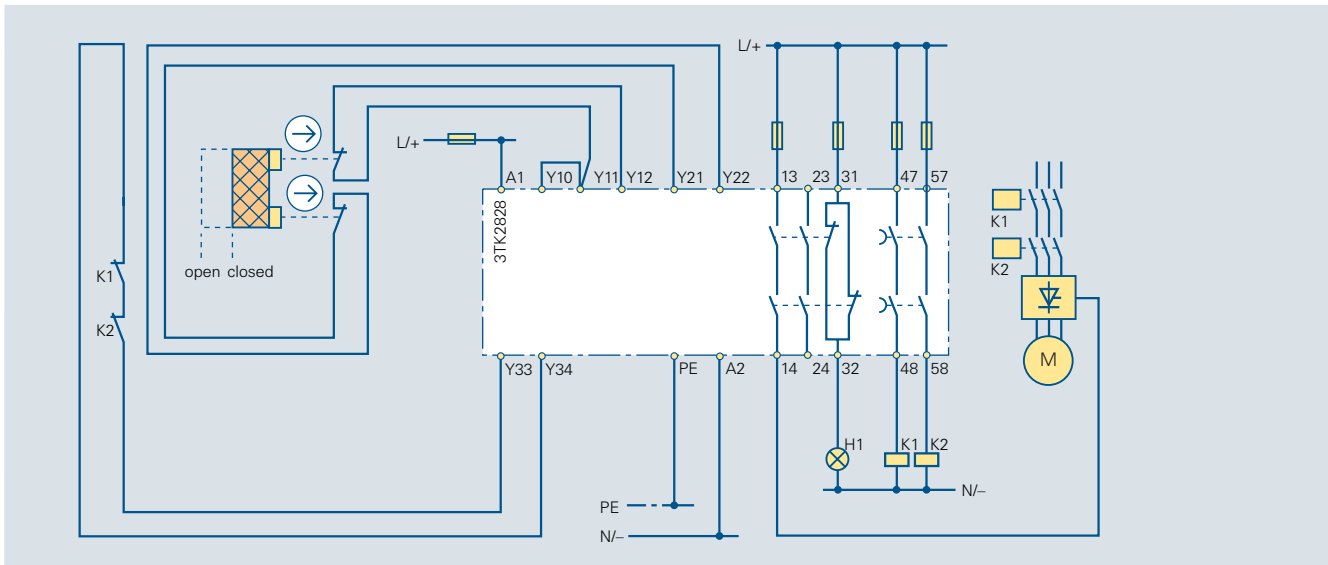

Circuit diagram 6/47
 3TK2828 for protective door monitoring with 2 SIGUARD position switches, stop Category 1, Category 3 acc. to EN 954-1, two-channel, with feedback circuit, autostart

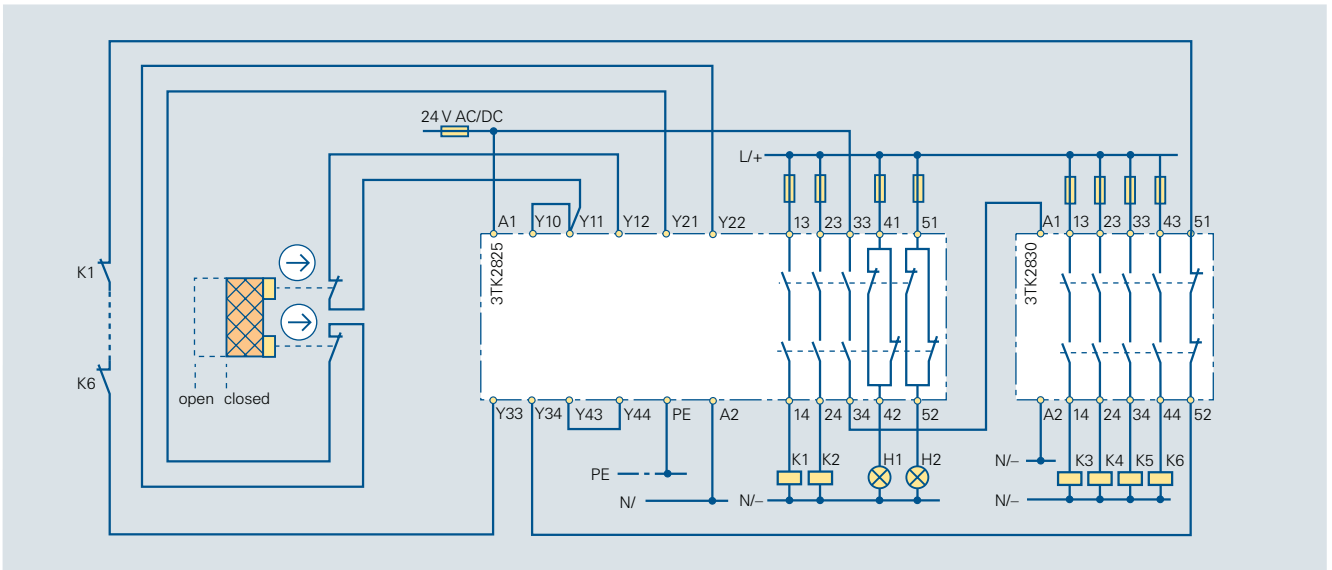

Circuit diagram 6/48
 3TK2825 expanded by 3TK2830 for protective door monitoring with 2 SIGUARD position switches,
 Category 4 acc. to EN 954-1, two-channel, with feedback circuit, autostart

Protective door monitoring with contactless SIGUARD magnetically-operated switches

Protective doors are monitored using an evaluation unit up to Cat. 3 acc. to EN 954-1 (circuit diagram 6/50).

The evaluation unit can be operated, both with automatic restart as well as with monitored start. The start button is not necessarily required.

Monitoring several protective doors with evaluation unit up to Cat. 3 acc. to EN 954-1

A maximum of eight SIGUARD magnetically-operated switches can be connected to the 3SE6808-6DB evaluation unit. If one of the eight magnetically-operated switches is actuated (the protective door is opened), then the unit stops. There is a PLC signaling output (switching to p) for each input. The fail-safe shutdown is realized using two relay safety outputs.

If an input is not used, then the appropriate terminals of the NO contact must be jumpered.

For limited safety requirements, the evaluation unit can also be used without a start button. For this particular application contact X1 must be supplied with 24 V DC (Y1 or external).

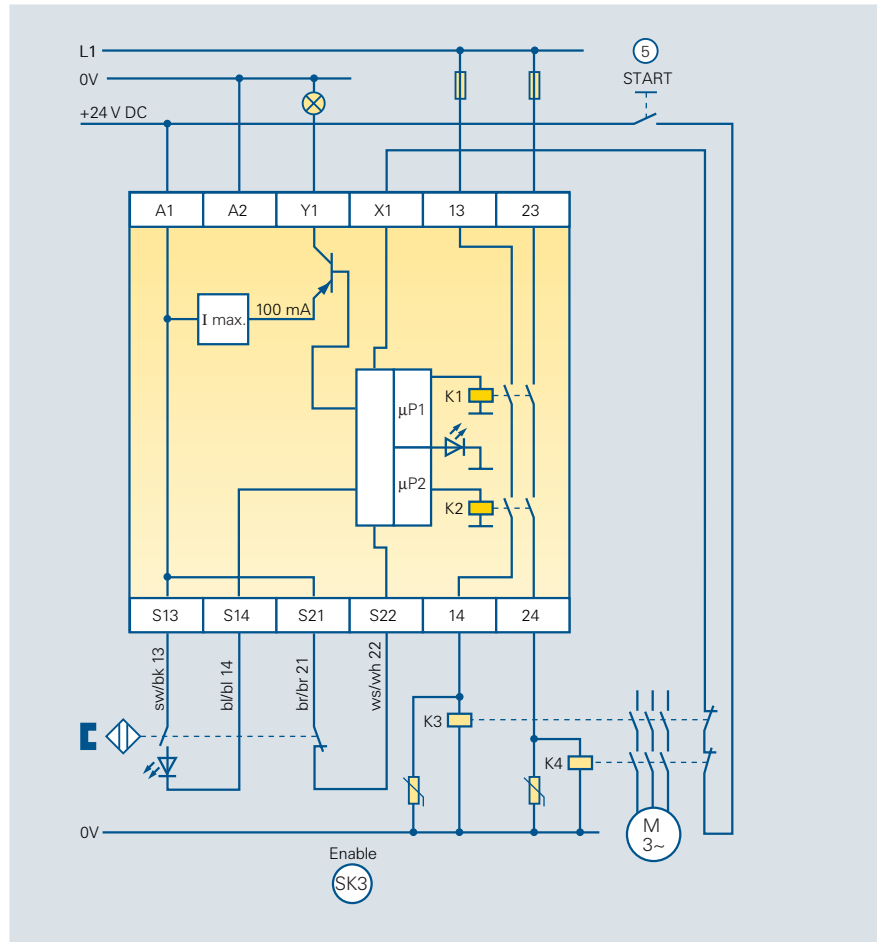

Circuit diagram 6/49
SIGUARD magnetically-operated switch with evaluation unit 3SE6801-1CC for Category 3 acc. to EN 954-1

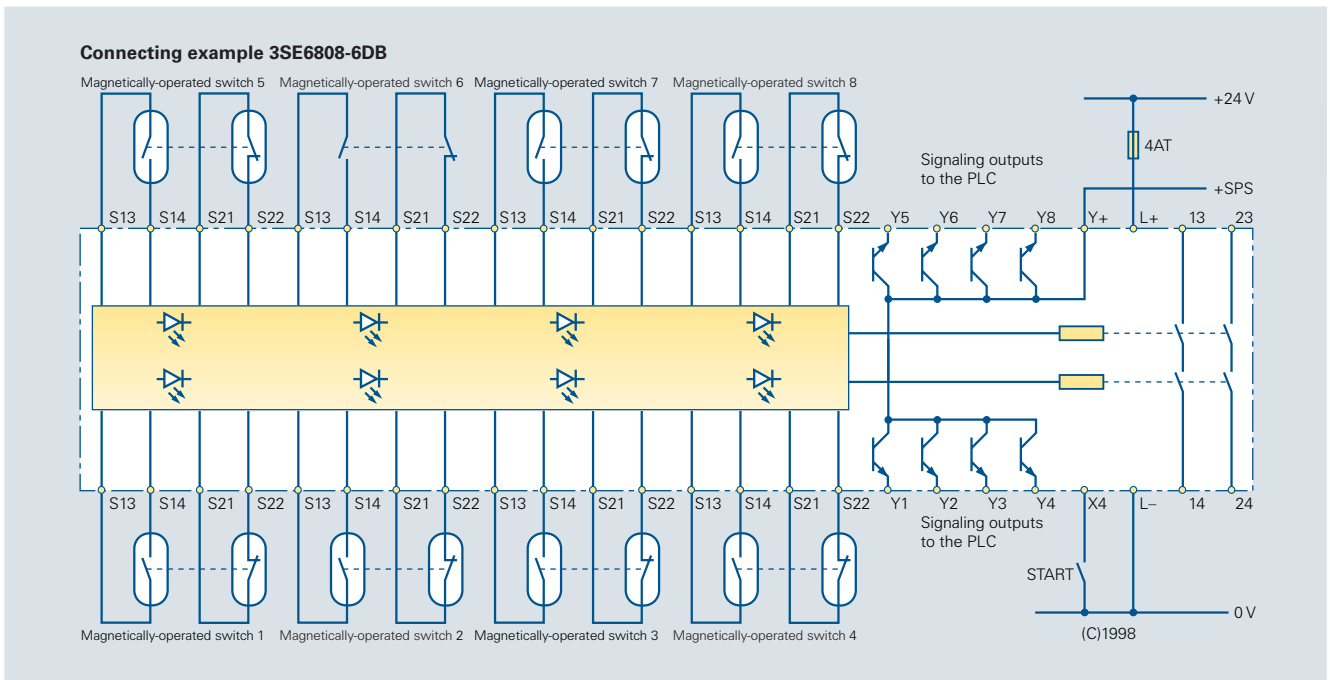

Circuit diagram 6/50

A max. of 8 protective doors can be monitored using SIGUARD magnetically-operated switches and evaluation unit 3SE6808-6DB for Category 3 acc. to EN 954-1

Technical data of the evaluation unit for SIGUARD 3SE6808-6DB magnetically-operated switches

Connection cross-section:	Max. 2 x 2.5 mm ² with end sleeves, min. 1.5 mm ²	Supply voltage, acc. to IEC 38:	24 V DC +10%/-10%
Mounting in an enclosure:	Snapped onto 35 mm standard mounting rails acc. to DIN EN 50022	Own power drain:	24 V DC nom. 6.5 W, max. 9.1 W
Degree of protection acc. to DIN VDE 0470 Part 1:	Terminals: IP 20 Enclosure: IP 40	Safety outputs:	13-14, 23-24
Weight:	Approx. 300 g	Fusing, output circuits:	4 A T
Mounting position:	Any, front panel visible when the cabinet is open	Limiting continuous current at the max. ambient temperature:	4 A
Fusing, power supply voltage:	4 A T	Switching current, max.:	8 A
Permissible ambient temperature:	Operation: -10°C/+55°C Storage: -55°C/+80°C	Switching voltage, max.:	400 V ~ 50/60 Hz, 250 V
Overvoltage Category:	2 (2.5 kV)	Switching capacity:	AC 15-C 250
Degree of pollution:	2	AC:	Max. 1500 VA
Rated insulation voltage:	250 V acc. to DIN VDE 0110 Part 1 (1997-04)	DC voltage:	Refer to the load limiting characteristic, SR4 safety relay
		Category:	3 (acc. to EN 954-1)

6.3.3 Press control devices

Press control devices with contactors also refer to Pages 6/14 – 6/15

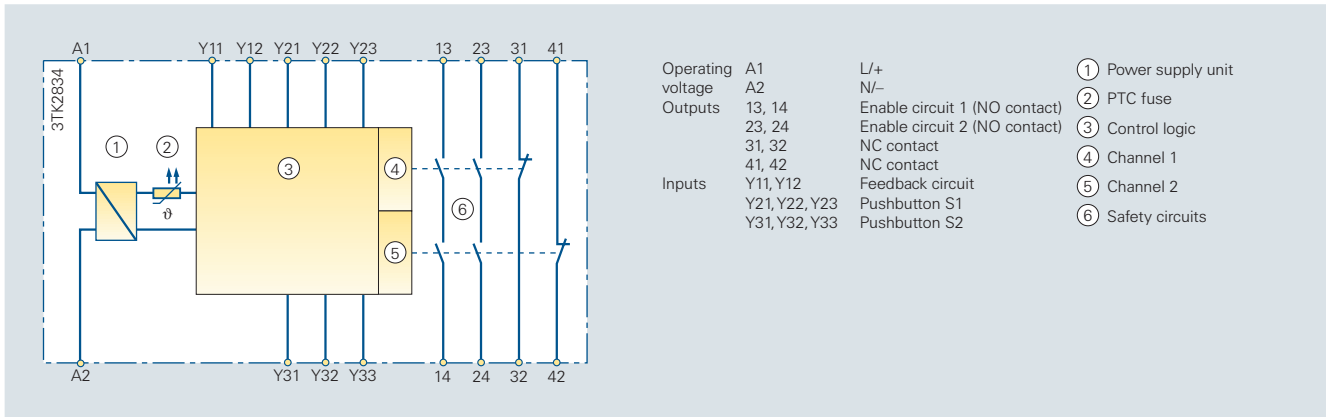

Circuit diagram 6/51
Internal circuit diagram of the 3TK2834 two-hand control device

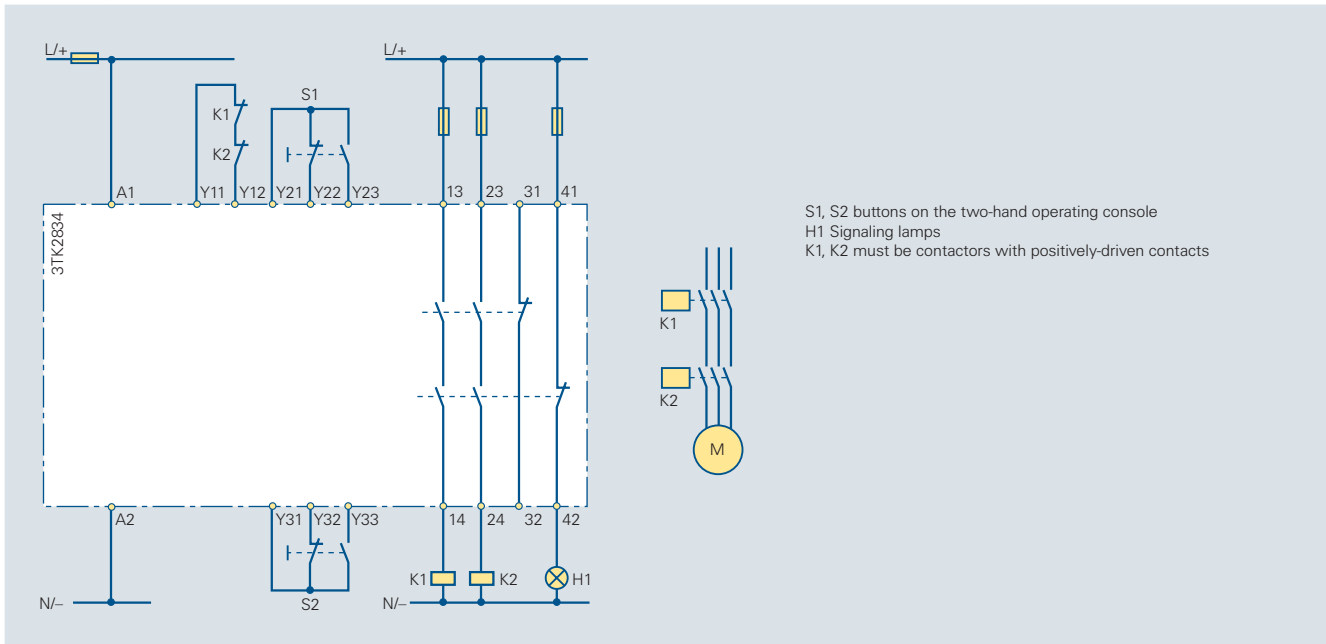

Circuit diagram 6/52
3TK2834 two-hand control device, Category 4 acc. to EN 954-1

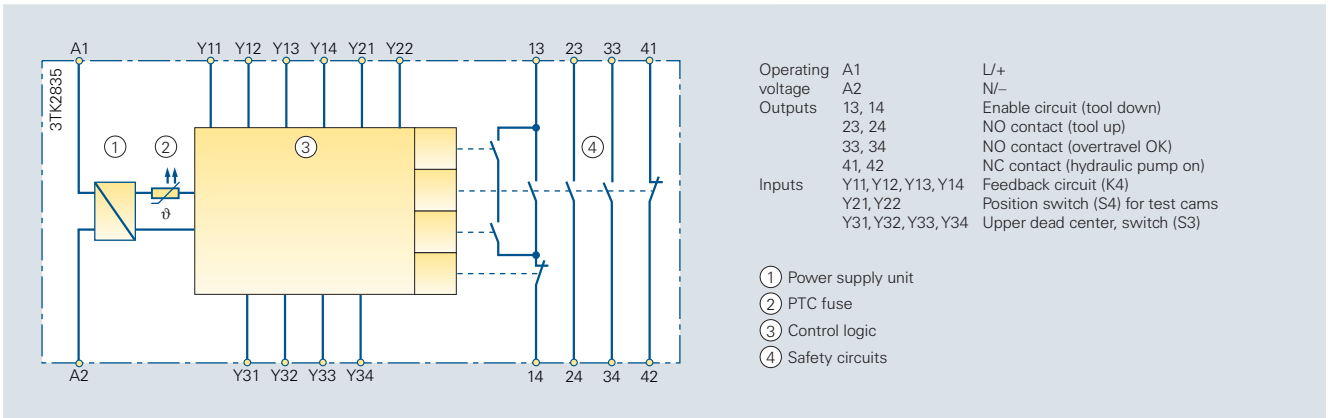



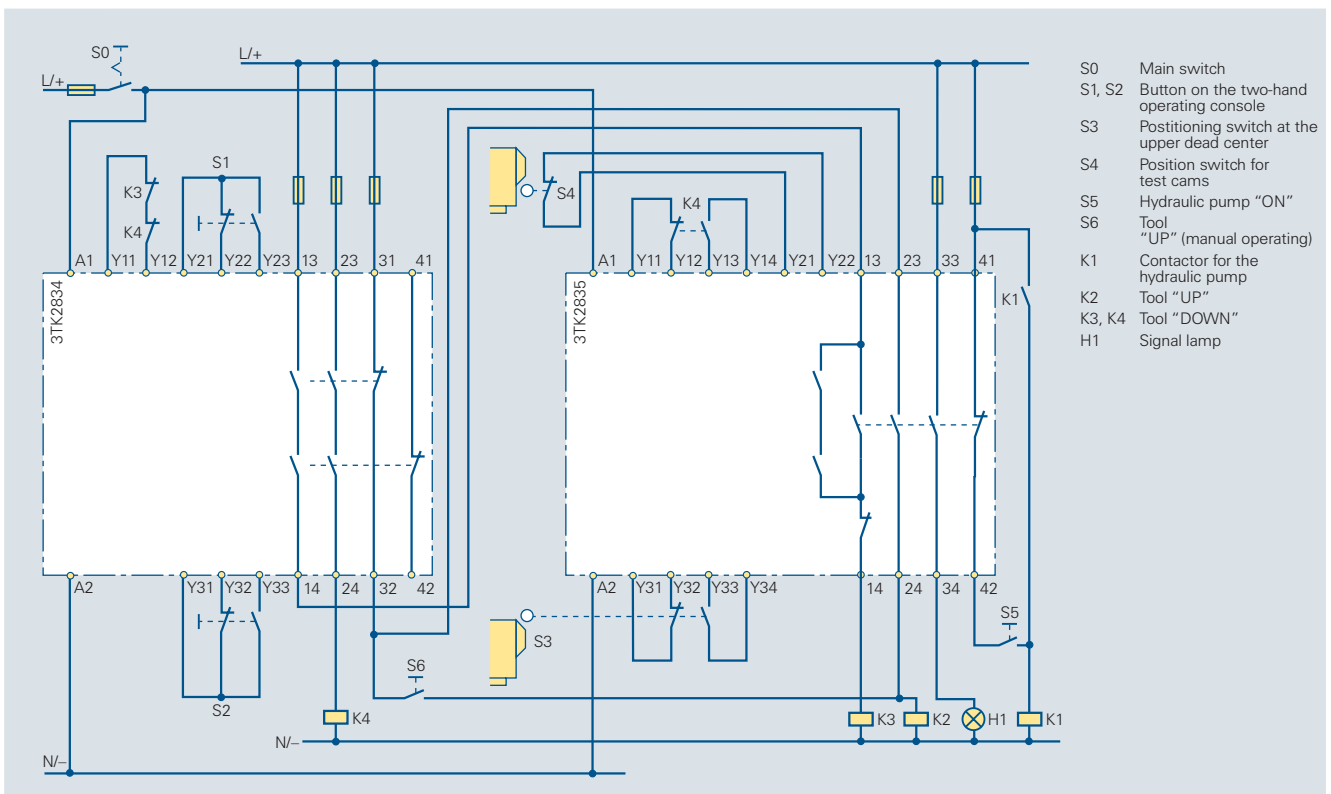

Circuit diagram 6/53
Internal circuit diagram of the 3TK2835 overtravel tester



Circuit diagram 6/54
3TK2834 two-hand control device in conjunction with a 3TK2835 overtravel tester to monitor the overtravel in linear hydraulic-, pneumatic- and spindle presses acc. to VBG 7 n 5.2 § 11, Category 4 acc. to EN 954-1

Sequence after the press has been powered-up:

1. The hydraulic pump is powered-up with S5, the ram is moved up to upper dead center, if required, using S6.
2. Press S1, S2 at the two-hand operating console until the position switch for the test cams (S4) opens.
3. Release S1, S2.
4. Depress S1, S2 again: Signal lamp H1 lights-up (bright), if the overtravel is OK.
5. Release S1, S2: The ram returns to the upper dead center.
6. If the overtravel is OK, all of the outputs remain active until the control voltage is disconnected.

LEDs		Operation
POWER	RELEASE	
		Overtravel OK
		Overtravel erroneous or test still not executed

Fault situation

If the cam actuates position switch S4, then the signal lamp H1 is not lit-up. The machine part, which is potentially hazardous, can then only be moved to the upper dead center using S6.

This press can then no longer be used. Contact the technician to check the press.

A more detailed description of the function of the 3TK2834 two-hand control device is provided in the Instruction Manual, Order No. 3ZX1012-0TK28-7CA1, for the overtravel tester 3ZX1012-0TK28-6CA1.

Fig. 6/1

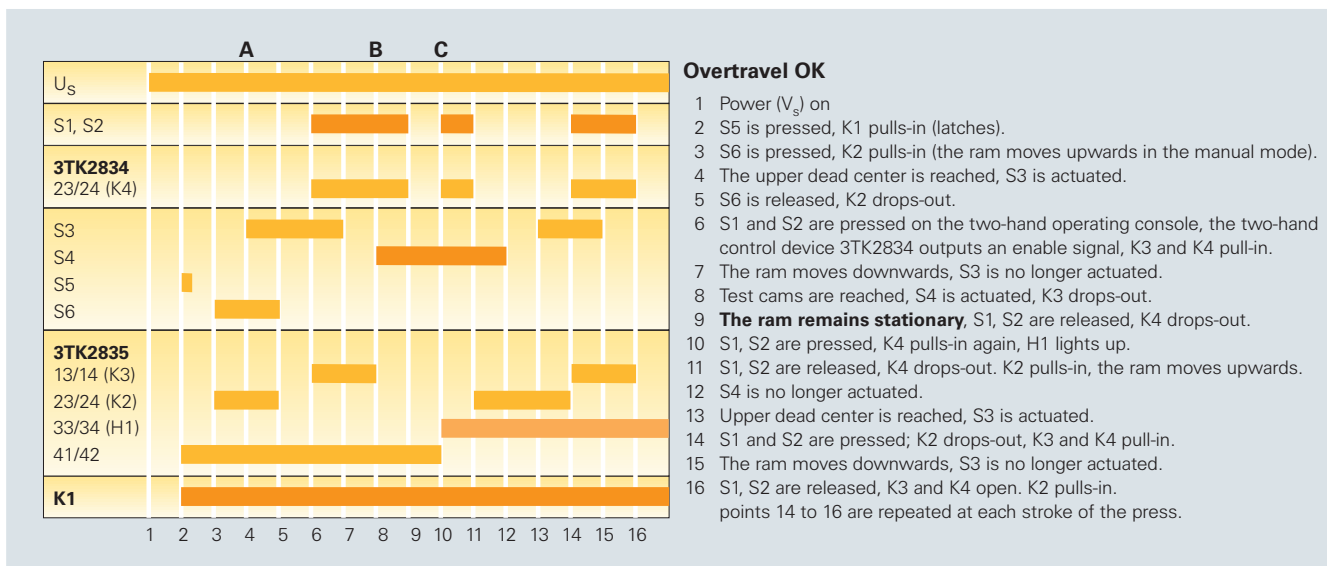

Fig. 6/2

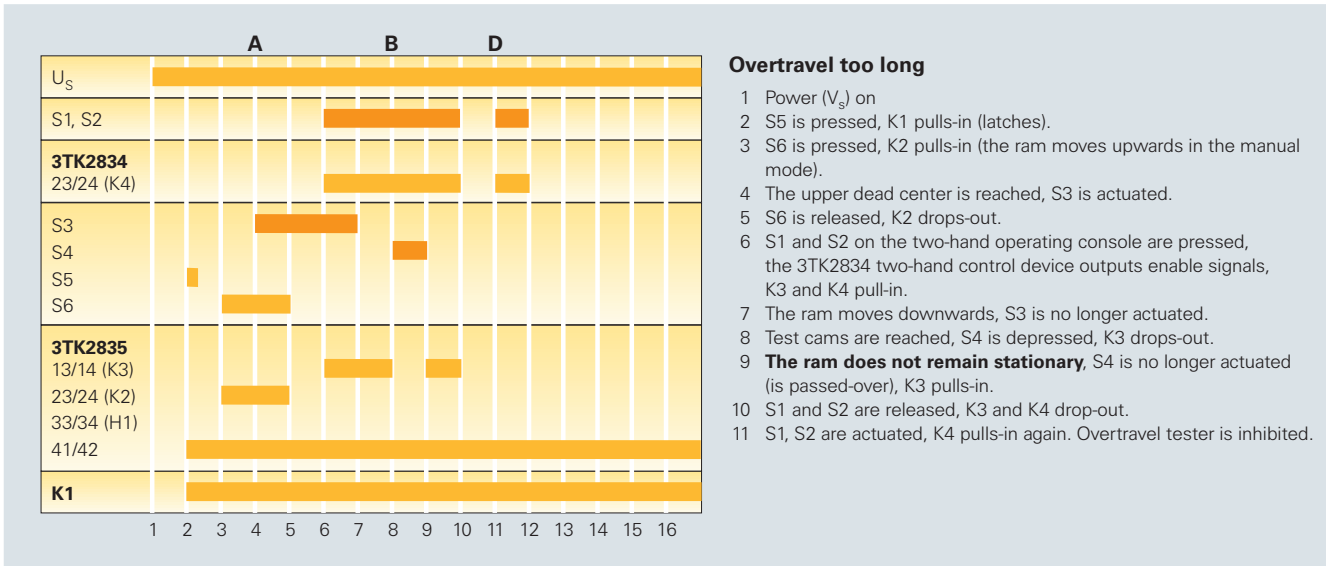

Fig. 6/3

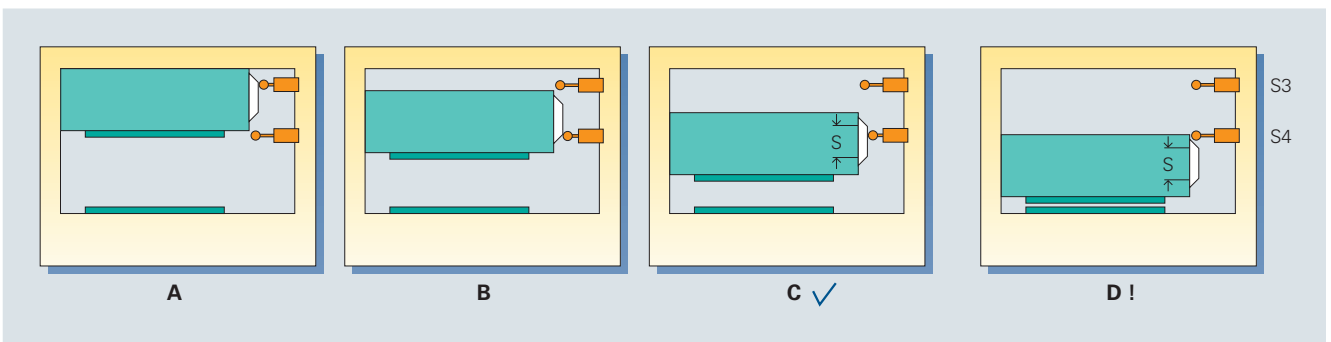

Fig. 6/4
 Function schematic of the press control.
 The permissible overtravel "s" corresponds to the length of the cam which actuates position switch S4.
 According to ZH 1/456, the press manufacturer must define "s."

6.4 Contactless Protective Devices

6.4.1 Circuit examples for SIGUARD light curtains

SIGUARD light curtains can be supplied externally from 24 V DC. All of the connecting cables must be screened.

Standard evaluation for SIGUARD light curtains (3RG7817-1DB2)

The system, as standard is operated with a monitored start, which requires a start button. For an automatic re-start, a jumper must be inserted between terminals T11 and X2.

The muting evaluation unit can also be used to monitor SIGUARD light curtains, without actually using the muting function.

Terminals AML and 53 must be jumpered to simulate a muting lamp (as this isn't required in this case). The NC contacts of external contactors must be connected in the feedback circuit between terminals ERK and ERK+.

If one of the safety outputs at the light curtain opens, the evaluation unit shuts down. Refer to circuit diagram 6/59 for connecting-up the electronic outputs.

Fault monitoring with muting function

The use of the light curtain in the muting mode with four muting sensors with floating NO contact outputs is shown in circuit diagram 6/60.

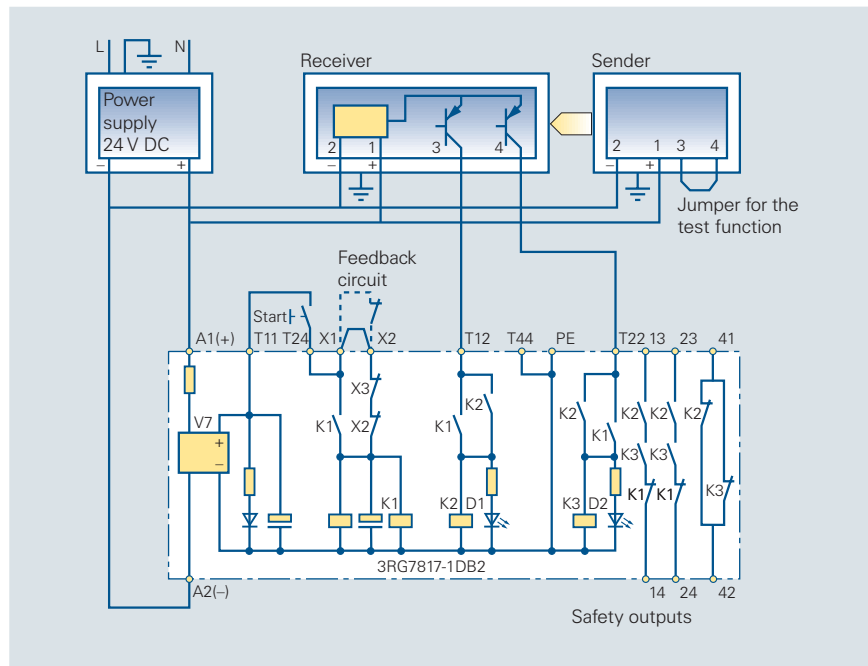

Circuit diagram 6/55
Connecting-up the standard evaluation unit for SIGUARD light curtains

- It is mandatory to use a muting lamp (white) and this is monitored via the evaluation unit (terminal 53).
- The start button cannot be bypassed. Automatic re-start is not possible.
- Terminal 63 can have a maximum 1.5 A load. In order to avoid an overload condition, the receiver ground must be connected to terminal 63.

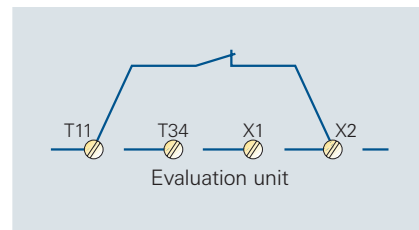

Circuit diagram 6/56
Automatic restart

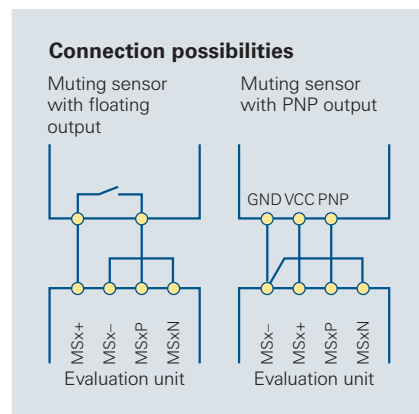

Circuit diagram 6/57
Connecting different muting sensors

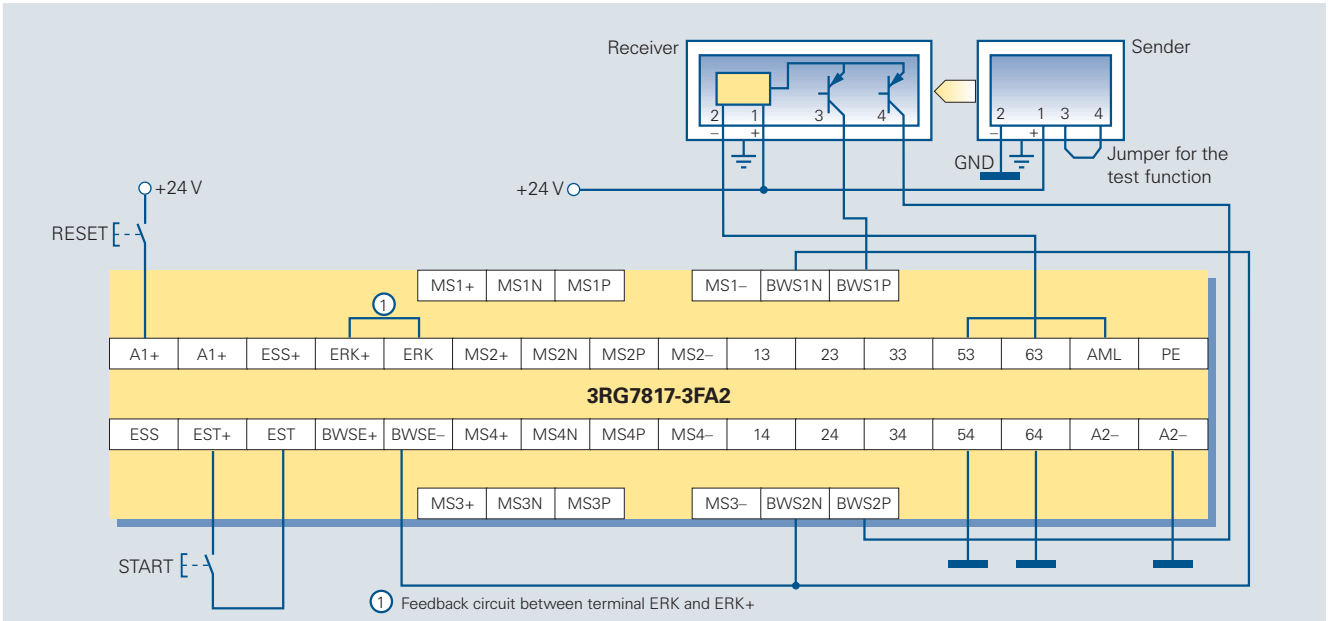

Circuit diagram 6/58
Connecting-up the muting evaluation unit without using the muting function

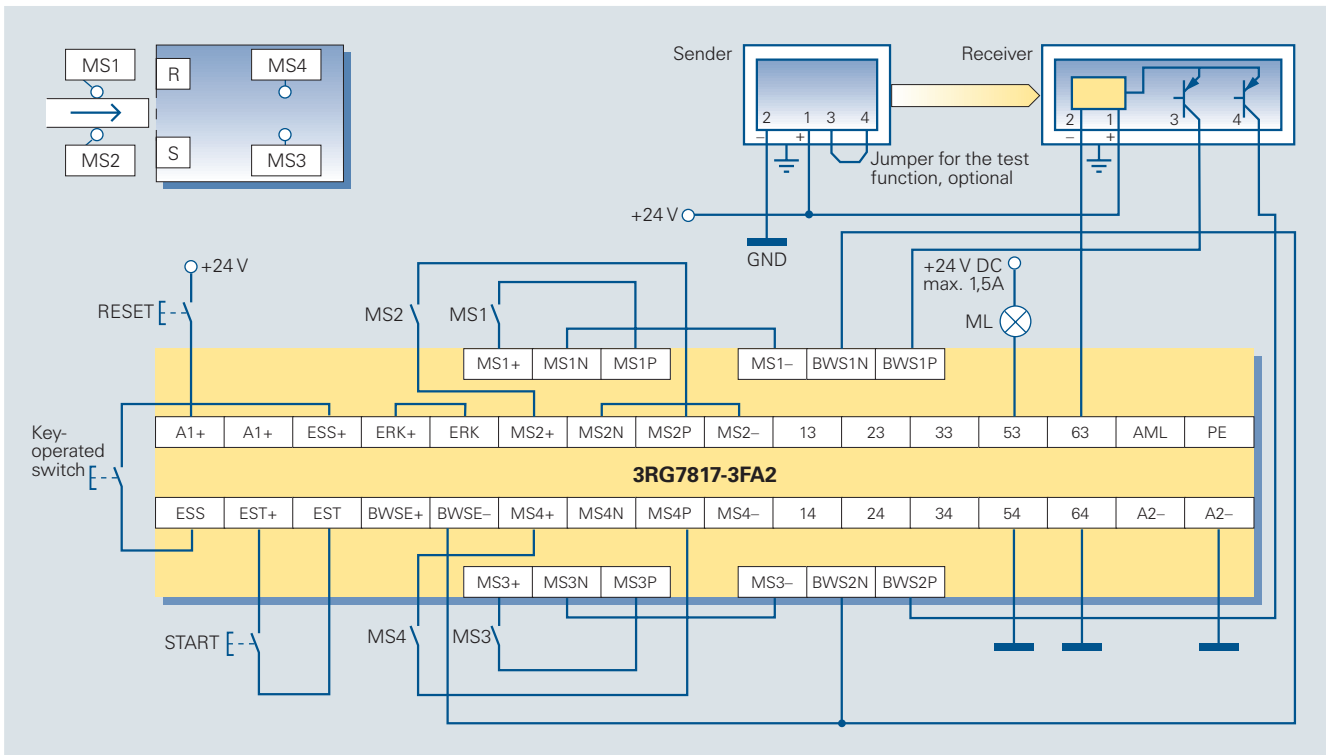

Circuit diagram 6/59
Connecting-up the muting evaluation unit using the muting function

Connecting-up the safety-related semiconductor outputs

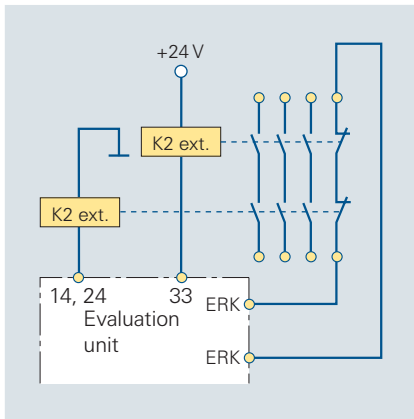

Circuit diagram 6/60

Safety-related outputs

14, 24: Safety-related semiconductor outputs (p switching) with cyclic testing function. If the evaluation unit has been started, and the light curtain is not interrupted, these outputs switch through 24 V DC. The output is open when the evaluation units switched-off.

33: Safety-related semiconductor output (n switching) with cyclic testing function. If the evaluation unit has been started, and the light curtain is not interrupted, the output switches to ground.

Note

The electronic safety-related outputs are destroyed by voltage spikes exceeding approx. 60 V. Thus, the motor contactors used must be provided with diode damping circuits, which act as arc quenching elements.

The arc quenching elements must be connected in parallel with the loads, but not in parallel to the outputs.

We recommend, as external contactors, Siemens auxiliary contactors with integrated diode, type 3RH1122-1JB40 or the combination consisting of the auxiliary contactor (without free-wheeling diode) 3RH1122-1BB40 and the 3RT1916-1DG00 diode.

Using the key-operated switch

Muting operation can be simulated using the key-actuated switch. This is necessary, if, when the muting sensors are actuated, the power supply of the muting evaluation unit fails. In this condition, the evaluation unit would always detect a fault, and it would no longer run-up at the start. The plant or system would not be able to be started

If the key-operated switch is actuated, the evaluation unit switches-into the muting mode for max. 10 min so that the material being transported or conveyed can be removed from the muting zone. If a muting sensor is no longer actuated, the device stops and must be re-started.

6.4.2 Circuit examples for SIGUARD light barriers

Evaluation unit and light barriers for Category 2 acc. to EN 954-1

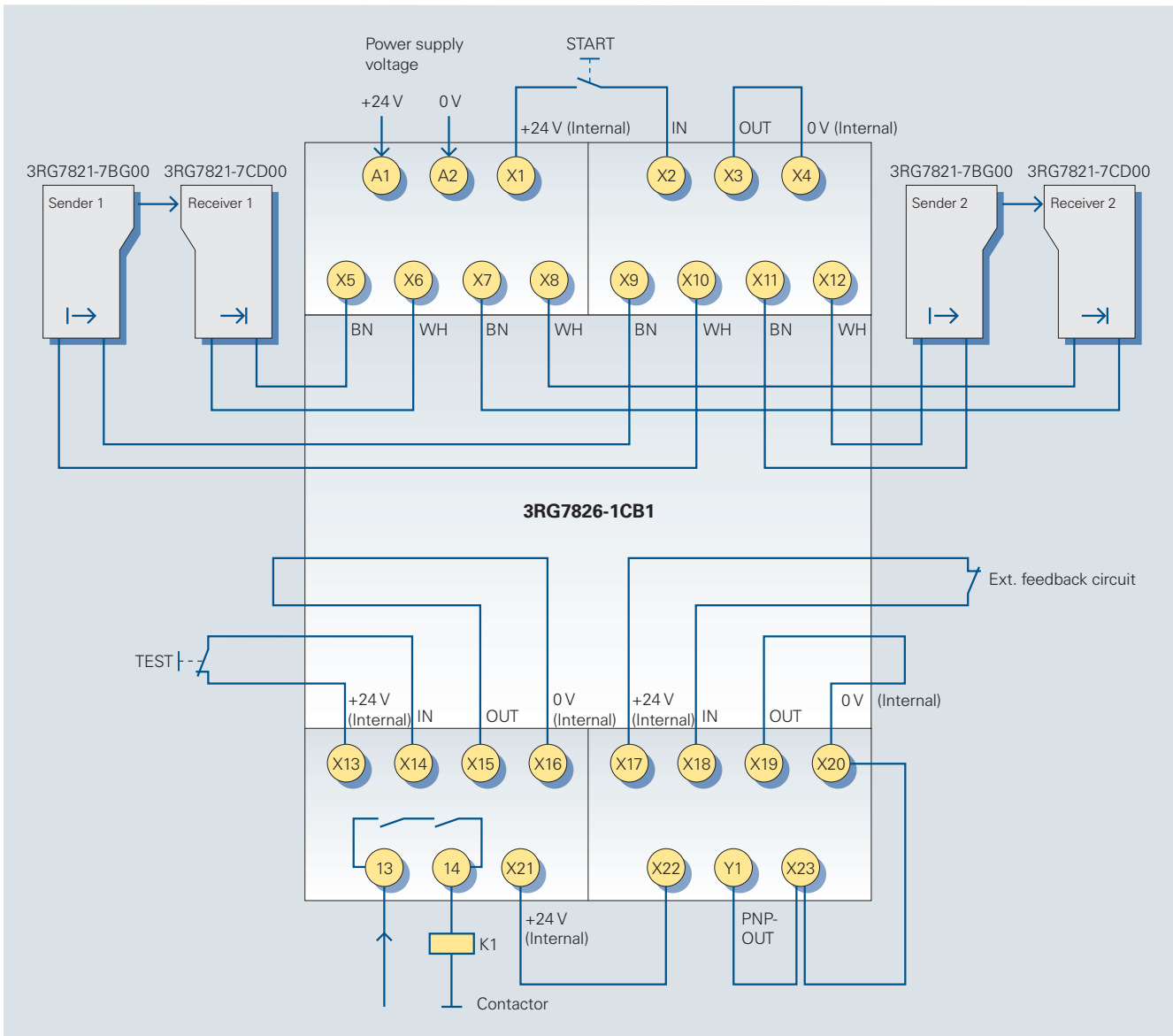

Circuit diagram 6/61

**Evaluation unit and light barriers
for Category 4 acc. to EN 954-1**

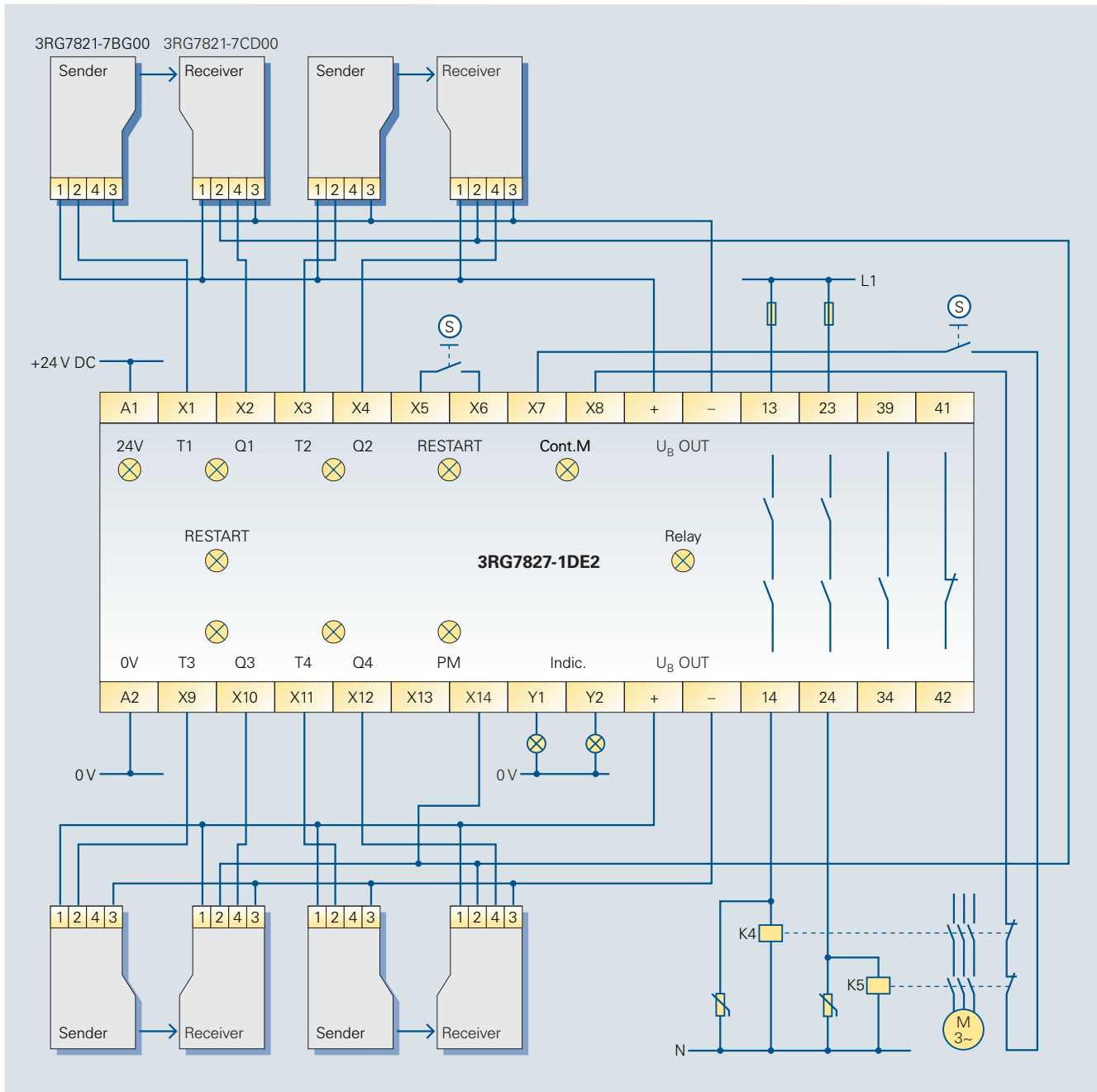

Circuit diagram 6/62

6.5 SIGUARD Switching Strips



Circuit examples with evaluation unit

SIGUARD switching strips, together with the 3RG78 57-1BD evaluation unit, can be used as a safety system up to Category 3 acc. to EN 954-1. The evaluation electronics in the 22.5 mm enclosure is used to evaluate the sender/receiver signal and to monitor the complete system for faults and errors.

The power supply voltage of the evaluation unit is 24 V DC. 2 relay outputs are available as safety-related outputs. A semiconductor output (n-switching) can be used to issue a signal to a PLC. After the switching strip has been actuated, the device must be enabled using a manual start button, so that the system can restart.

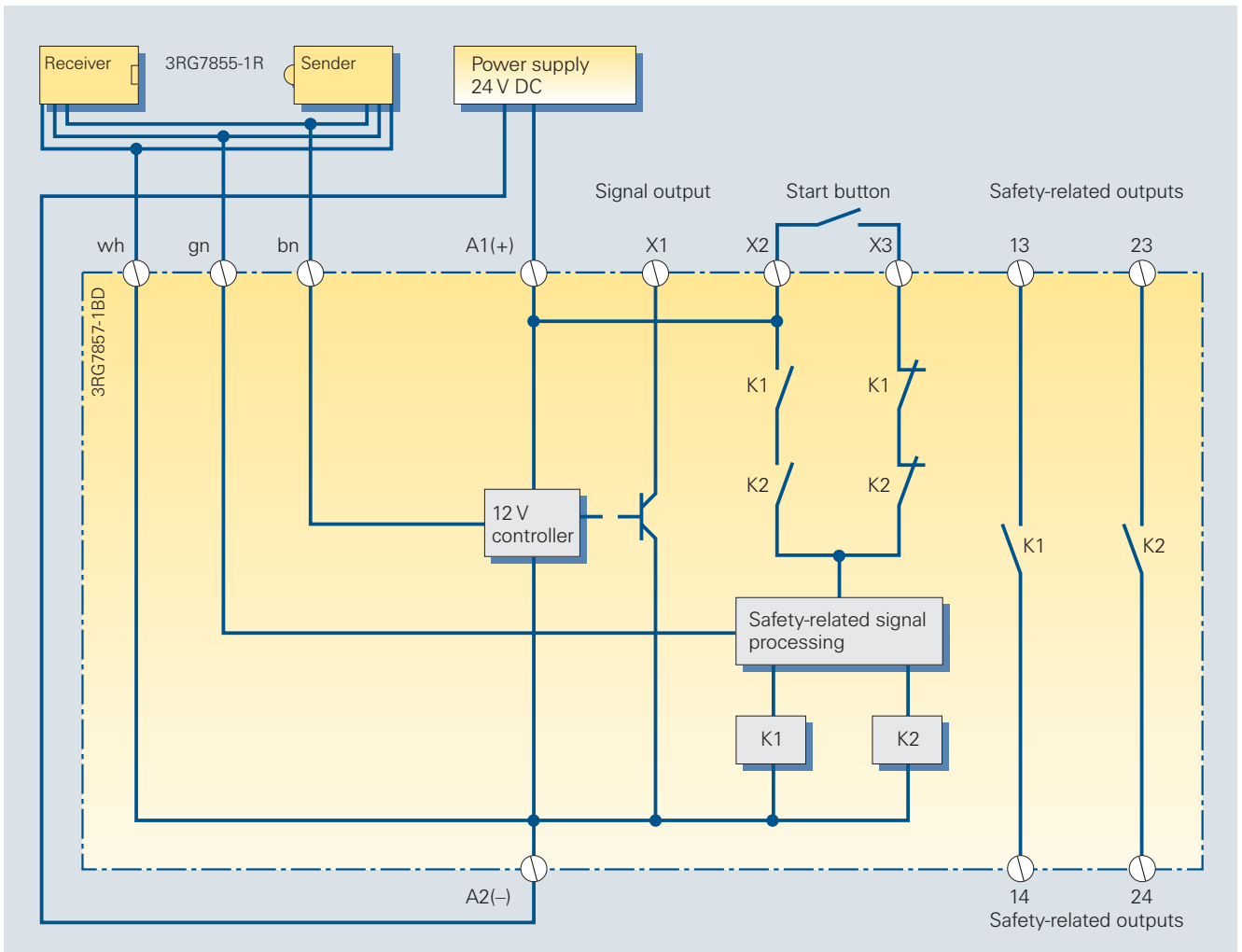

Circuit diagram 6/63

6.6 SIMATIC S5-95F – Safe Shutdown using Approved EMERGENCY OFF Function Modules

EMERGENCY OFF with SIMATIC S5-95F

S5-95F can be used to implement EMERGENCY OFF circuits, as it fulfills the requirements of EN 954-1 and/or IEC 61508.

Standard function modules have been written, and have been approved by the German Trade Association.

These function modules either permit inputs and outputs to be assigned with a resolution of one bit (one input = one output), or input/output assignment, with a byte resolution. This means, that after evaluation, several EMERGENCY OFF pushbuttons can be used to shutdown a common EMERGENCY OFF circuit from the S5-95F with user-friendly display capability.

Under certain prerequisites, it is permissible to activate/deactivate light barriers (muting).

Connecting-up the individual functions

The sensors (EMERGENCY OFF pushbuttons, light curtains etc.) can either be connected to the fail-safe onboard- or the fail-safe external I/O of the S5-95F. In this case, for single-channel sensors, the signal cables are connected in parallel to the sub-units, or for two-channel sensors, each signal cable is connected to a sub-unit. In both cases, the signal is connected redundantly to the automation unit (PLC), however, from the perspective of the user program, one single input is addressed. If a cross-circuit test is required, then the sensor connecting cables are not fed from a constant 24 V supply voltage, but from an onboard digital output, configured using the COM 95F parameterizing software.

This test output is then briefly switched-out for the test and the zero signal checked at the associated inputs.

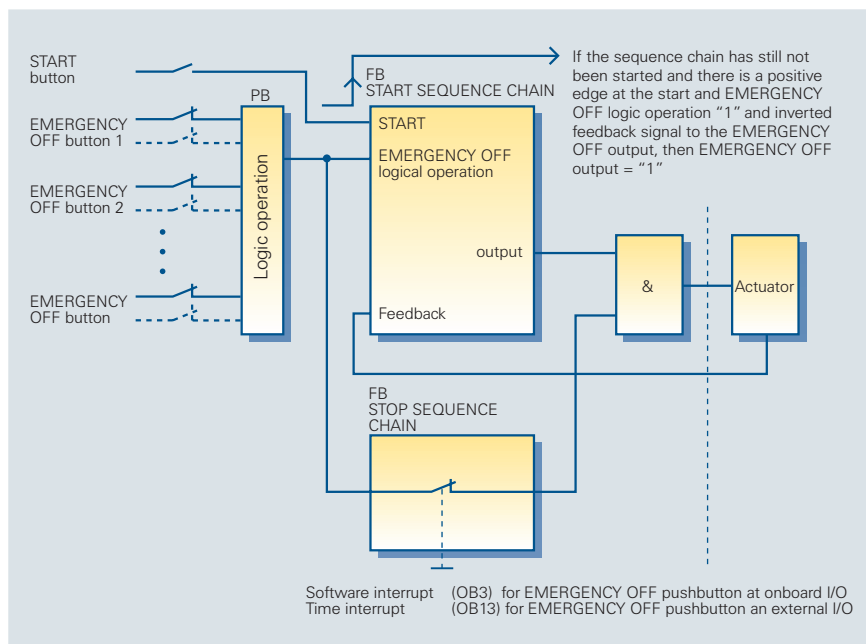

Circuit diagram 6/64
Principle of identifying and shutting down EMERGENCY OFF sequence chains for fail-safe S5-95F PLC

The feedback contact of the contacts and the start button can be connected-up to both non-fail-safe as well as fail-safe inputs.

Information regarding circuit diagram 6/65

The sensors can be logically combined with one another in a program module, and the result assigned to an intermediate flag, which in turn is permanently assigned to an EMERGENCY OFF output. In the most basic case, all of the inputs (NC contacts) are switched in series by the program, and assigned the flags. The start module, logically combines, in the cyclic program, the signals "intermediate flag, start button and checkback signal input" with one another. The EMERGENCY OFF output may only be energized, if the intermediate flag, i.e. the logical combination of the sensors, has a logical 1 signal, the checkback signal input of the shutdown element has a logical 0 signal, and a positive edge from the start button has been identified.

The parameterized stop module switches the set EMERGENCY OFF output off, as soon as the associated intermediate flag has a 0 signal. Depending on how the sensors are connected to the fail-safe onboard- or the fail-safe external I/O, this shutdown is realized in the organization block OB3 within a max. of 10 ms, or in the OB13 within a max. of 120 ms. The EMERGENCY OFF output can only be re-energized when the associated intermediate flag again has a logical 1 signal (e.g. the EMERGENCY OFF pushbutton which was pressed, has been released again), a positive edge is read-in at the start button and the checkback signal input has a 0 signal.

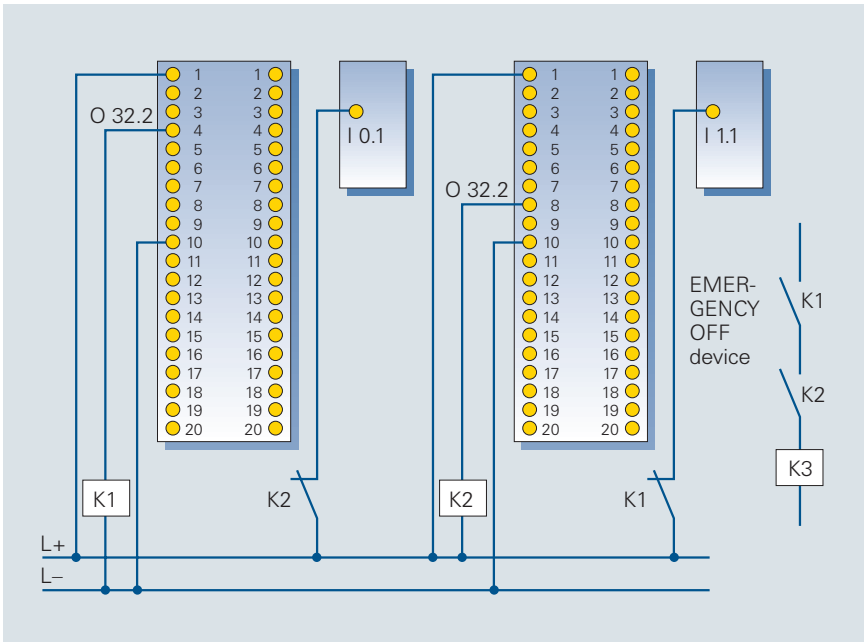

Circuit diagram 6/65
Controlling redundant auxiliary contactors with checkback signals via positively-driven auxiliary contacts

The following examples show how the ON/acknowledge button and an EMERGENCY OFF control device can be connected to the onboard I/O of the S5-95F.

Rule

The EMERGENCY OFF control devices must be connected to fail-safe inputs. EMERGENCY OFF control devices can be used both with fail-safe onboard- as well as fail-safe external I/O.

The ON/acknowledge button can be connected, both to the fail-safe onboard I/O, the fail-safe external I/O, as well as the non-fail-safe external I/O.

Example 1

A circuit for indirectly controlling the EMERGENCY OFF stop device via two redundant auxiliary contactors and with checkback signals via two positively-driven auxiliary contacts via the external I/O is illustrated in Fig. 6/66.

Example 2

Fig. 6/67 shows how the ON/acknowledge button and an EMERGENCY OFF control device can be connected to the fail-safe onboard I/O.

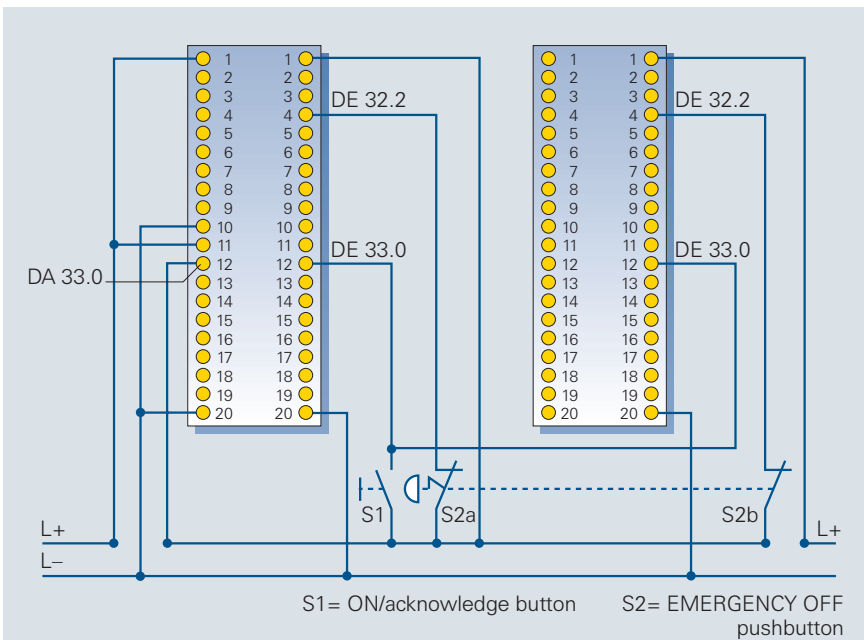

Circuit diagram 6/66
Connecting the ON/acknowledge button and the EMERGENCY OFF control devices with cross-circuit monitoring

6.7 ET 200S SIGUARD

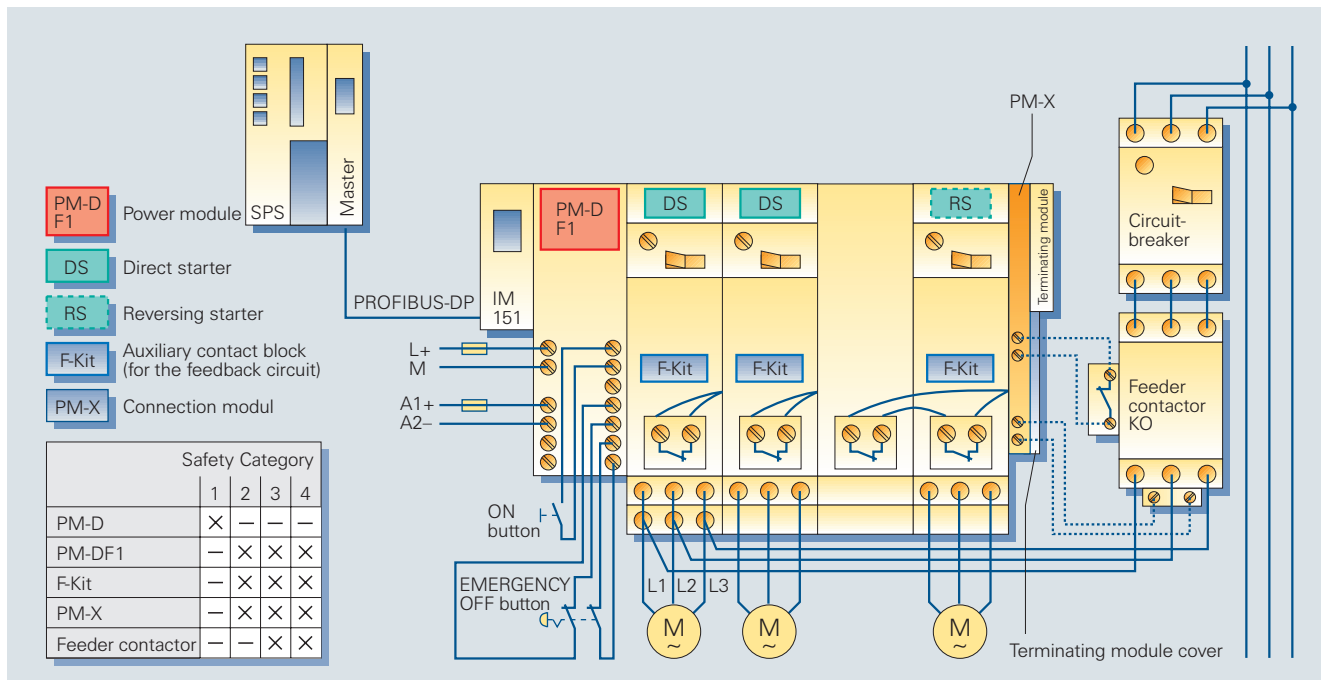

Circuit diagram 6/67
EMERGENCY OFF with monitored start, Category 4

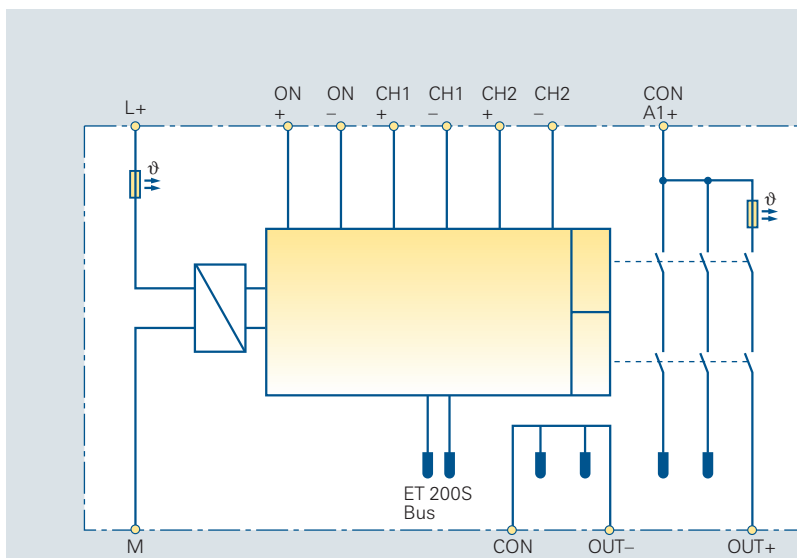

Explanation

When commissioning the circuit, proceed as follows:

- Connect auxiliary voltage V1 to terminals L+, M
- Connect auxiliary voltage V2 to terminals CON A1+, CON A2-
- The EMERGENCY OFF circuits at terminals CH1+, CH1- and CH2+, CH2- must be closed
- The system becomes operational as soon as the ON button, connected to terminals ON+, ON- is actuated.

EMERGENCY OFF circuits and ON buttons are monitored for cross-circuit during operation.

Cross-reference:
Also refer to Part 2.31 ET 200S SIGUARD, Page 2/49, as well as the "SIMATIC ET 200S" Manual – Order No. GE S7 151-1AA00-8AA0

The basic configuration of a SIGUARD Power Module is shown in the circuit diagram using as an example PM-D F1, EMERGENCY OFF with monitored start

Circuit diagram 6/68
Block diagram of the SIGUARD Power Module PM-D F1

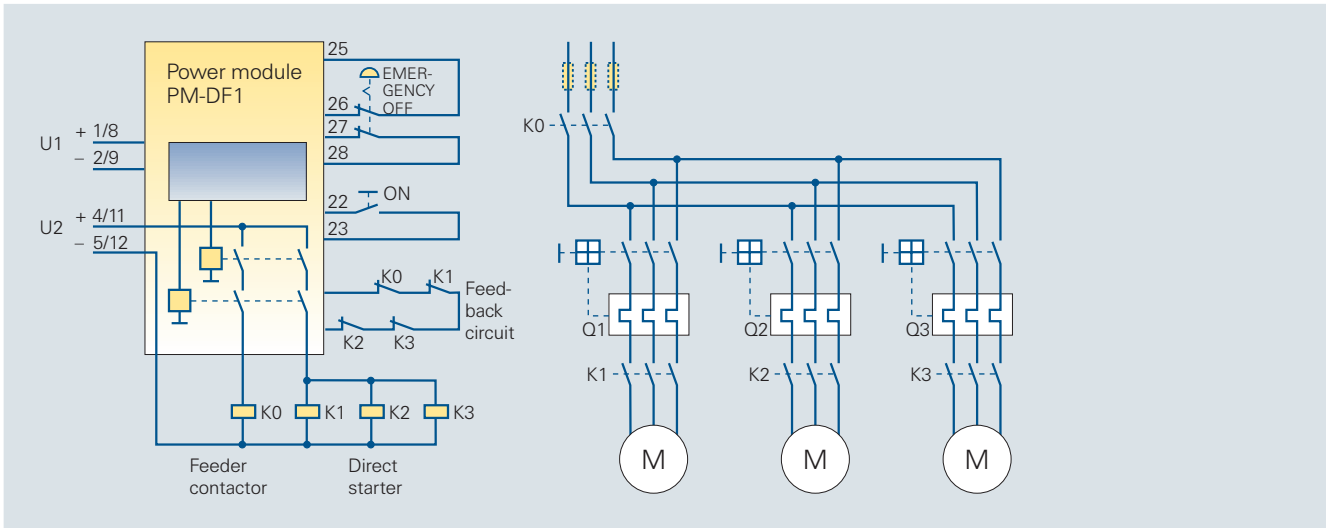

Circuit diagram 6/69
 Monitoring load feeders, EMERGENCY OFF, stop Category 0, monitored start, Category 4.
 The load feeders are monitored, as the contactor NC contacts (F kit) are switched as "feedback circuits" in series with the ON button.

6.8 Controlling Drives

This section describes application examples using the SIMOVERT MASTERDRIVES drive system for applications with AC variable-speed drives.

The examples show how applications can be implemented. The solution required for the machine must be harmonized with the machine function. This results in individual parameterization or control commands for applications, Stop Category 1.

The solutions shown are implemented using the SIMOVERT MASTERDRIVES and SIMODRIVE 611 drive systems.

The "SAFE STANDSTILL" function can be implemented with the device-specific "SAFE OFF" functions or "Start inhibit". In this case, the appropriate information must be observed in the product descriptions.

SIMOVERT MASTERDRIVES
Vector Control Catalog DA 65.10

SIMOVERT MASTERDRIVES
Motion Control Catalog DA 65.11

SIMODRIVE 611
Catalog NC 60.1 and NC 60.2

6.8.1 Application examples for EMERGENCY-STOP stop Category 0

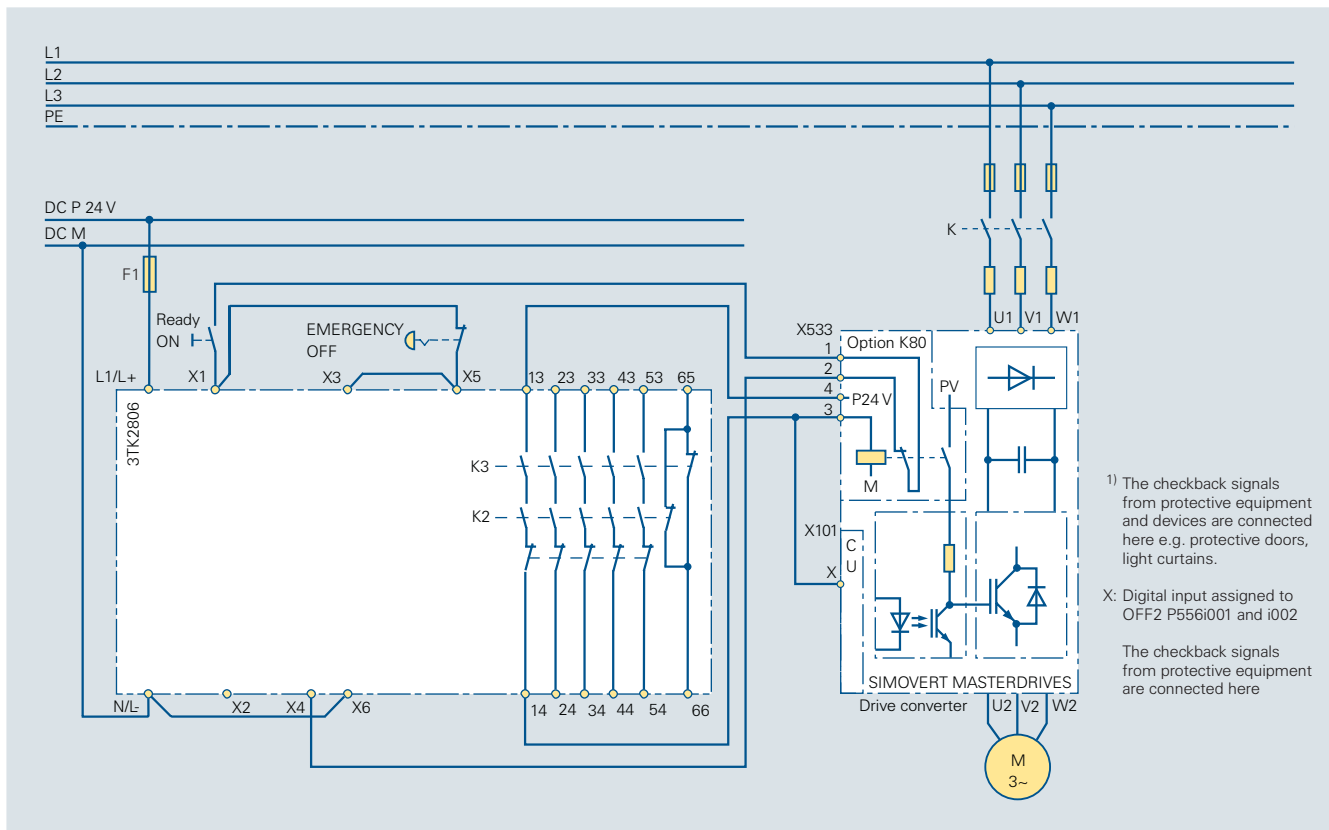

Circuit diagram 6/70
Stop Category 0, single-channel, with feedback circuit. Category 3 acc. to EN 954-1 function with motor which is coasting down

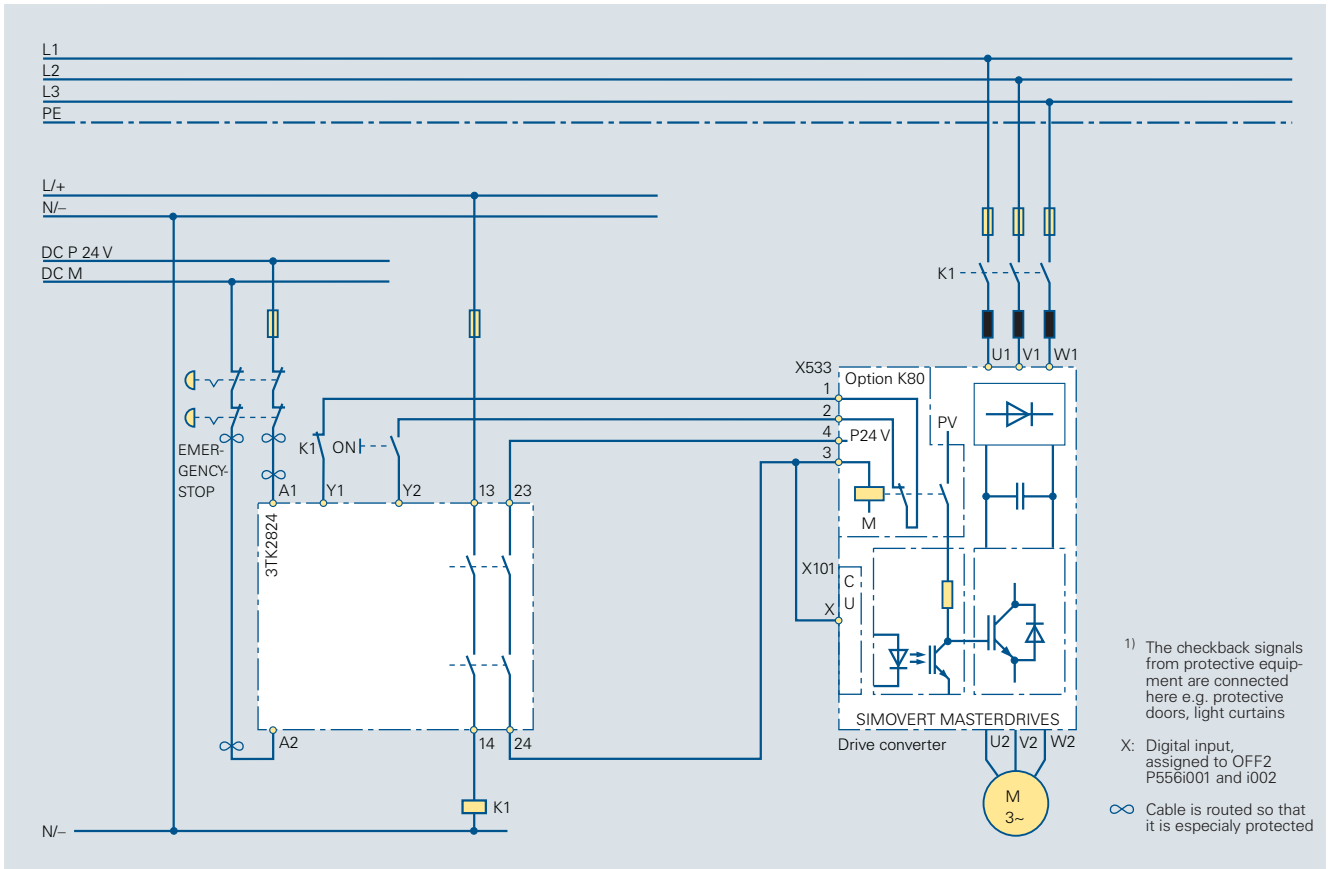

Circuit diagram 6/71
 Stop Category 0, two-channel, with feedback circuit. Category 3 acc. to EN 954-1.
 Function with motor which is coasting down

6.8.2 Application examples for EMERGENCY-STOP stop Category 1

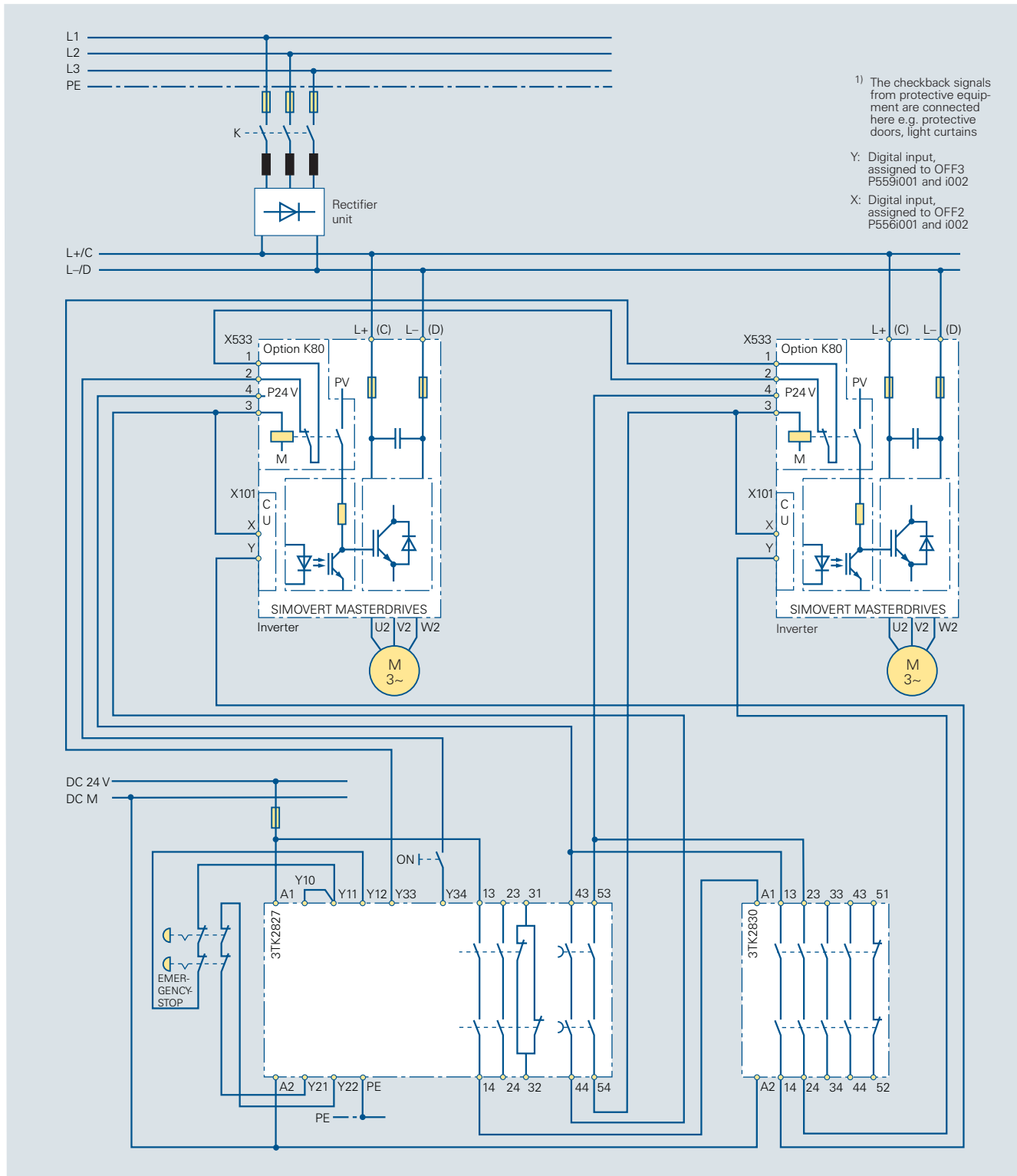

Circuit diagram 6/72

Stop Category 1, two-channel with feedback circuit. Category 3 acc. to EN 954-1. Function with controlled motor stop along the torque limit.

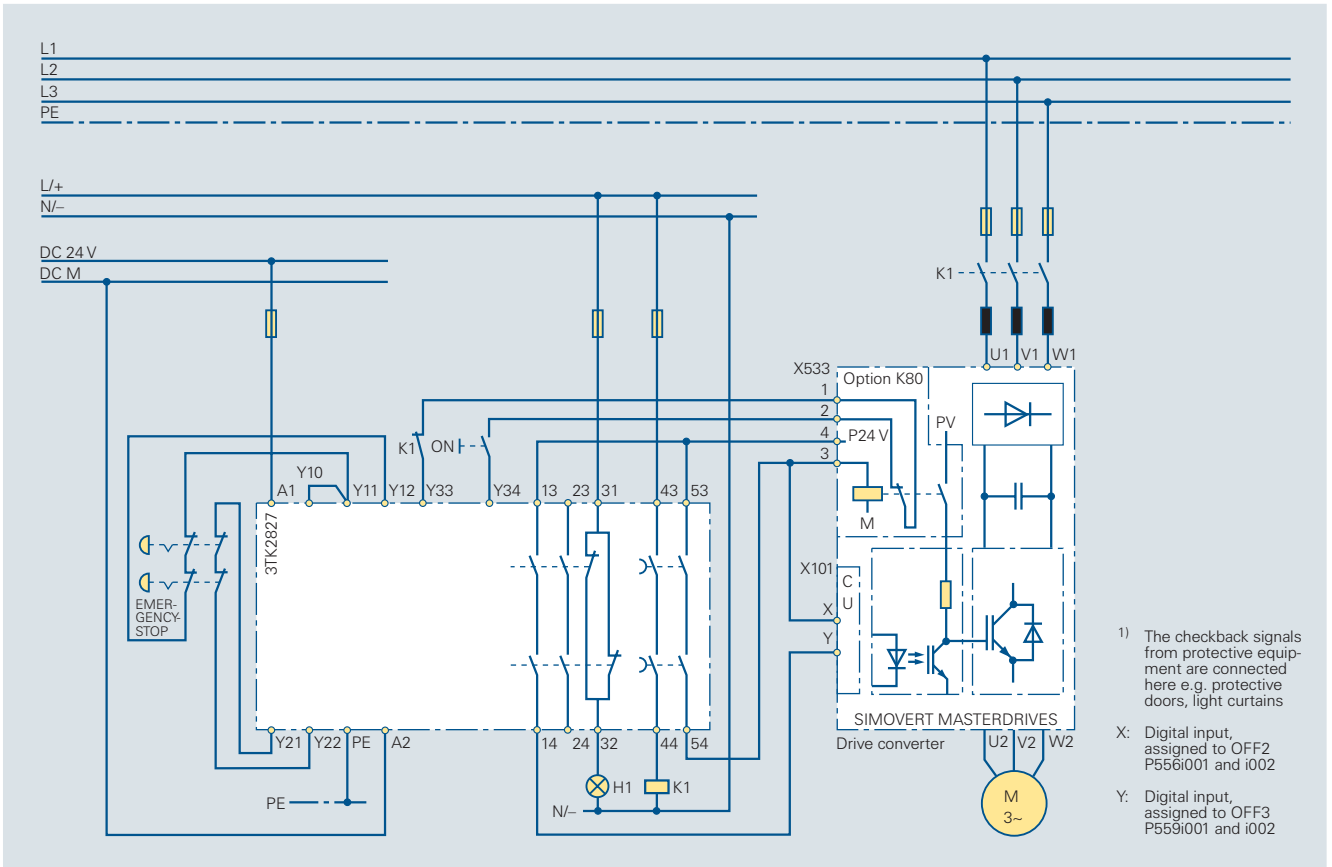

Circuit diagram 6/73
 Stop Category 1, two-channel, with feedback circuit. Category 3 acc. to EN 954-1.
 Function with controlled motor stop along the torque limit.

This datasheet has been downloaded from:

www.DatasheetCatalog.com

Datasheets for electronic components.