

SUMMARY

High performance 32-bit/40-bit floating-point processor optimized for high performance audio processing

Code compatible with all other SHARC DSPs

The ADSP-21266 processes high performance audio while enabling low system costs

Audio decoders and post processor-algorithms support.

Nonvolatile memory can be configured to contain a combination of PCM 96kHz, Dolby Digital, Dolby Digital EX, DTS-ES Discrete 6.1, DTS-ES Matrix 6.1, DTS 96/24 5.1, MPEG2 AAC LC, MPEG2 BC 2ch, Dolby Pro Logic II, Dolby Pro Logic 2x and DTS Neo:6

Single-Instruction Multiple-Data (SIMD) computational architecture—two 32-bit IEEE floating-point/32-bit fixed-point/40-bit extended precision floating-point computational units, each with a multiplier, ALU, shifter, and register file

High bandwidth I/O—a parallel port, an SPI port, six serial ports, a digital audio interface (DAI), and JTAG

DAI incorporates two precision clock generators (PCGs), an input data port (IDP) that includes a parallel data acquisition port (PDAP), and three programmable timers, all under software control by the signal routing unit (SRU)

On-chip memory—2M bits of on-chip SRAM and a dedicated 4M bits of on-chip mask-programmable ROM

Serial ports offer left-justified sample pair and I²S support via 12 programmable and simultaneous receive or transmit pins, which support up to 24 transmit or 24 receive I²S channels of audio when all 6 serial ports (SPORTs) are enabled or six full duplex TDM streams of up to 128 channels per frame

The ADSP-21266 is available with a 150 MHz or a 200 MHz core instruction rate. For complete ordering information, see [Ordering Guide on Page 44](#).

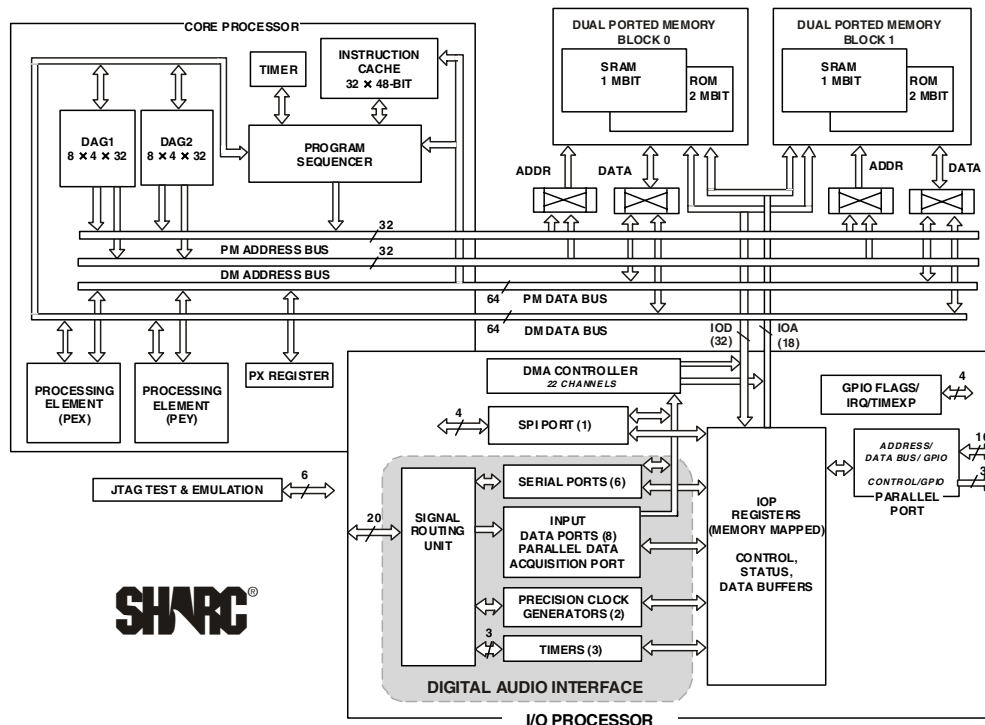

Figure 1. Functional Block Diagram

SHARC and the SHARC logo are registered trademarks of Analog Devices, Inc.

Rev. A

Information furnished by Analog Devices is believed to be accurate and reliable. However, no responsibility is assumed by Analog Devices for its use, nor for any infringements of patents or other rights of third parties that may result from its use. Specifications subject to change without notice. No license is granted by implication or otherwise under any patent or patent rights of Analog Devices. Trademarks and registered trademarks are the property of their respective owners.

ADSP-21266

KEY FEATURES

At 200 MHz (5 ns) core instruction rate, the ADSP-21266 operates at 1200 MFLOPS peak/800 MFLOPS sustained performance whether operating on fixed or floating point data

400 MMACS sustained performance at 200 MHz

Code compatibility— At assembly level, uses the same instruction set as other SHARC DSPs

Super Harvard Architecture—three independent buses for dual data fetch, instruction fetch, and nonintrusive, zero-overhead I/O

2M bits on-chip dual-ported SRAM (1M bit block 0, 1M bit block 1) for simultaneous access by core processor and DMA

4M bits on-chip dual-ported mask-programmable ROM (2M bits in block 0 and 2M bits in block 1)

Dual data address generators (DAGs) with modulo and bit-reverse addressing

Zero-overhead looping with single-cycle loop setup, providing efficient program sequencing

Single instruction multiple data (SIMD) architecture provides:

- Two computational processing elements
- Concurrent execution—Each processing element executes the same instruction, but operates on different data
- Parallelism in busses and computational units allows single cycle executions (with or without SIMD) of a multiply operation; an ALU operation; a dual memory read or write; and an instruction fetch

Transfers between memory and core at up to four 32-bit floating- or fixed-point words per cycle, sustained 2.4G bytes/s bandwidth at 200 MHz core instruction rate. In addition, 900M Bytes/sec is available via DMA

Accelerated FFT butterfly computation through a multiply with add and subtract instruction

DMA Controller supports:

- 22 zero-overhead DMA channels for transfers between the ADSP-21266 internal memory and serial ports (12), the input data port (IDP) (eight), the SPI-compatible port (one), and the parallel port (one)
- 32-bit background DMA transfers at core clock speed, in parallel with full-speed processor execution

Asynchronous parallel/external port provides:

- Access to asynchronous external memory
- 16 multiplexed address/data lines that can support 24-bit address external address range with 8-bit data or 16-bit address external address range with 16-bit data
- 66M Byte per sec transfer rate for 200 MHz core rate
- 50M Byte per sec transfer rate for 150 MHz core rate
- 256 word page boundaries
- External memory access in a dedicated DMA channel
- 8- to 32-bit and 16- to 32-bit word packing options
- Programmable wait state options: 2 to 31 CCLK

Digital audio interface (DAI) includes six serial ports, two precision clock generators, an input data port, three programmable timers, and a signal routing unit

Serial ports provide:

Six dual data line serial ports that operate at up to 50M bits/s for a 200 MHz core and up to 37.5M bits/s for a 150 MHz core on each data line—each has a clock, frame sync, and two data lines that can be configured as either a receiver or transmitter pair

Left-justified sample pair and I²S support, programmable direction for up to 24 simultaneous receive or transmit channels using two I²S compatible stereo devices per serial port

TDM support for telecommunications interfaces including 128 TDM channel support for newer telephony interfaces such as H.100/H.110

Up to 12 TDM stream support, each with 128 channels per frame

Companding selection on a per channel basis in TDM mode

Input data port provides an additional input path to the SHARC core configurable as either eight channels of I²S or serial data or as seven channels plus a single 20-bit wide synchronous parallel data acquisition port

Supports receive audio channel data in I²S, left-justified sample pair, or right-justified mode

Signal routing unit (SRU) provides configurable and flexible connections between all DAI components, six serial ports, two precision clock generators, three timers, an input data port/parallel data acquisition port, 10 interrupts, six flag inputs, six flag outputs, and 20 SRU I/O pins (DAI_Px)

Serial Peripheral Interface (SPI)

- Master or slave serial boot through SPI
- Full-duplex operation
- Master-slave mode multimaster support
- Open drain outputs
- Programmable baud rates, clock polarities, and phases
- 3 Muxed Flag/IRQ lines
- 1 Muxed Flag/Timer expired line

ROM based security features:

- JTAG access to memory permitted with a 64-bit key
- Protected memory regions that can be assigned to limit access under program control to sensitive code

PLL has a wide variety of software and hardware multiplier/divider ratios

JTAG background telemetry for enhanced emulation features

IEEE 1149.1 JTAG standard test access port and on-chip emulation

Dual voltage: 3.3 V I/O, 1.2 V core

Available in 136-ball BGA and 144-lead LQFP packages

Also available in lead-free packages

TABLE OF CONTENTS

General Description	4	Reset	19
ADSP-21266 Family Core Architecture	4	Interrupts	20
SIMD Computational Engine	4	Core Timer	20
Independent, Parallel Computation Units	5	Timer PWM_OUT Cycle Timing	21
Data Register File	5	Timer WDT_CAP Timing	21
Single-Cycle Fetch of Instruction and Four Operands	5	DAI Pin to Pin Direct Routing	22
Instruction Cache	5	Precision Clock Generator (Direct Pin Routing)	23
Data Address Generators With Zero-Overhead Hardware Circular Buffer Support	5	Flags	24
Flexible Instruction Set	6	Memory Read—Parallel Port	25
ADSP-21266 Memory and I/O Interface Features	6	Memory Write—Parallel Port	27
Dual-Ported On-Chip Memory	6	Serial Ports	29
DMA Controller	6	Input Data Port (IDP)	32
Digital Audio Interface (DAI)	6	Parallel Data Acquisition Port (PDAP).....	33
Serial Ports	6	SPI Interface—Master	34
Serial Peripheral (Compatible) Interface	8	SPI Interface—Slave	35
Parallel Port	8	JTAG Test Access Port and Emulation	36
Timers	8	Output Drive Currents	37
ROM Based Security	8	Test Conditions	37
Program Booting	8	Capacitive Loading	37
Phase-Locked Loop	8	Environmental Conditions	38
Power Supplies	8	Thermal Characteristics	38
Target Board JTAG Emulator Connector	9	136-Ball BGA Pin Configurations	39
Development Tools	9	144-Lead LQFP Pin Configurations	42
Designing an Emulator-Compatible DSP Board (Target)	10	Package Dimensions	43
Additional Information	10	Ordering Guide	44
Pin Function Descriptions	11		
Address Data Pins as Flags	14		
Boot Modes	14		
Core Instruction Rate to CLKIN Ratio Modes	14		
Address Data Modes	14		
ADSP-21266 Specifications	15		
Recommended Operating Conditions	15		
Electrical Characteristics	15		
Absolute Maximum Ratings	16		
ESD Sensitivity	16		
Timing Specifications	16		
Power-up Sequencing	18		
Clock Input	19		
Clock Signals	19		

REVISION HISTORY

4/04—Data Sheet Changed from Rev. 0 to Rev. A

Added notes to AD pins	11
Added $V_{IHCLKIN}$ and $V_{ILCLKIN}$ specifications	15
Changed specifications (t_{ALERW} , and t_{ALEHZ})	25-28
Updated 136-BGA package drawing	43
Added new part	44

ADSP-21266

GENERAL DESCRIPTION

The ADSP-21266 SHARC DSP is a member of the SIMD SHARC family of DSPs featuring Analog Devices Super Harvard Architecture. The ADSP-21266 is source code compatible with the ADSP-2126x, ADSP-21160 and ADSP-21161 DSPs as well as with first generation ADSP-2106x SHARC processors in SISD (Single-Instruction, Single-Data) mode. Like other SHARC DSPs, the ADSP-21266 is a 32-bit/40-bit floating-point processor optimized for high performance audio applications with its dual-ported on-chip SRAM, mask-programmable ROM, multiple internal buses to eliminate I/O bottlenecks, and an innovative Digital Audio Interface (DAI).

As shown in the Functional Block Diagram on Page 1, the ADSP-21266 uses two computational units to deliver a 5 to 10 times performance increase over previous SHARC processors on a range of DSP algorithms. Fabricated in a state-of-the-art, high speed, CMOS process, the ADSP-21266 DSP achieves an instruction cycle time of 5 ns at 200 MHz or 6.6 ns at 150 MHz. With its SIMD computational hardware, the ADSP-21266 can perform 1200 MFLOPS running at 200 MHz, or 900 MFLOPS running at 150 MHz.

Table 1 shows performance benchmarks for the ADSP-21266.

Table 1. ADSP-21266 Benchmarks (at 200 MHz)

Benchmark Algorithm	Speed (at 200 MHz)
1024 Point Complex FFT (Radix 4, with reversal)	46 μ s
FIR Filter (per tap) ¹	2.5 ns
IIR Filter (per biquad) ¹	10 ns
Matrix Multiply (pipelined)	
[3 \times 3] \times [3 \times 1]	22.5 ns
[4 \times 4] \times [4 \times 1]	40 ns
Divide (y/ \times)	15 ns
Inverse Square Root	22.5 ns

¹ Assumes two files in multichannel SIMD mode.

The ADSP-21266 continues SHARC's industry leading standards of integration for DSPs, combining a high performance 32-bit DSP core with integrated, on-chip system features. These features include 2 Mbits dual-ported SRAM memory, 4 Mbits dual-ported ROM, an I/O processor that supports 22 DMA channels, six serial ports, an SPI interface, external parallel bus, and Digital Audio Interface (DAI).

The block diagram of the ADSP-21266 on Page 1, illustrates the following architectural features:

- Two processing elements, each containing an ALU, multiplier, shifter, and data register file
- Data Address Generators (DAG1, DAG2)
- Program sequencer with instruction cache
- PM and DM buses capable of supporting four 32-bit data transfers between memory and the core at every core processor cycle

- Three Programmable Interval Timers with PWM Generation, PWM Capture/Pulse Width Measurement, and External Event Counter Capabilities
- On-chip dual-ported SRAM (2M bits)
- On-chip dual-ported, mask-programmable ROM (4M bits)
- JTAG test access port
- 8- or 16-bit parallel port that supports interfaces to off-chip memory peripherals
- DMA controller
- Six full-duplex serial ports
- SPI compatible interface
- Digital Audio Interface that includes two precision clock generators (PCG), an input data port (IDP), six serial ports, eight serial interfaces, a 20-bit synchronous parallel input port, 10 interrupts, six flag outputs, six flag inputs, three programmable timers, and a flexible signal routing unit (SRU)

Figure 2 on Page 5 shows one sample configuration of a SPORT using the precision clock generator to interface with an I²S ADC and an I²S DAC with a much lower jitter clock than the serial port would generate itself. Many other SRU configurations are possible.

ADSP-21266 FAMILY CORE ARCHITECTURE

The ADSP-21266 is code compatible at the assembly level with the ADSP-2136x and ADSP-2116x, and with the first generation ADSP-2106x SHARC DSPs. The ADSP-21266 shares architectural features with the ADSP-2136x and ADSP-2116x SIMD SHARC family of DSPs, as detailed in the following sections.

SIMD Computational Engine

The ADSP-21266 contains two computational processing elements that operate as a Single-Instruction Multiple-Data (SIMD) engine. The processing elements are referred to as PEX and PEY and each contains an ALU, multiplier, shifter, and register file. PEX is always active, and PEY may be enabled by setting the PEYEN mode bit in the MODE1 register. When this mode is enabled, the same instruction is executed in both processing elements, but each processing element operates on different data. This architecture is efficient at executing math intensive audio algorithms.

Entering SIMD mode also has an effect on the way data is transferred between memory and the processing elements. When in SIMD mode, twice the data bandwidth is required to sustain computational operation in the processing elements. Because of this requirement, entering SIMD mode also doubles the bandwidth between memory and the processing elements. When using the DAGs to transfer data in SIMD mode, two data values are transferred with each access of memory or the register file.

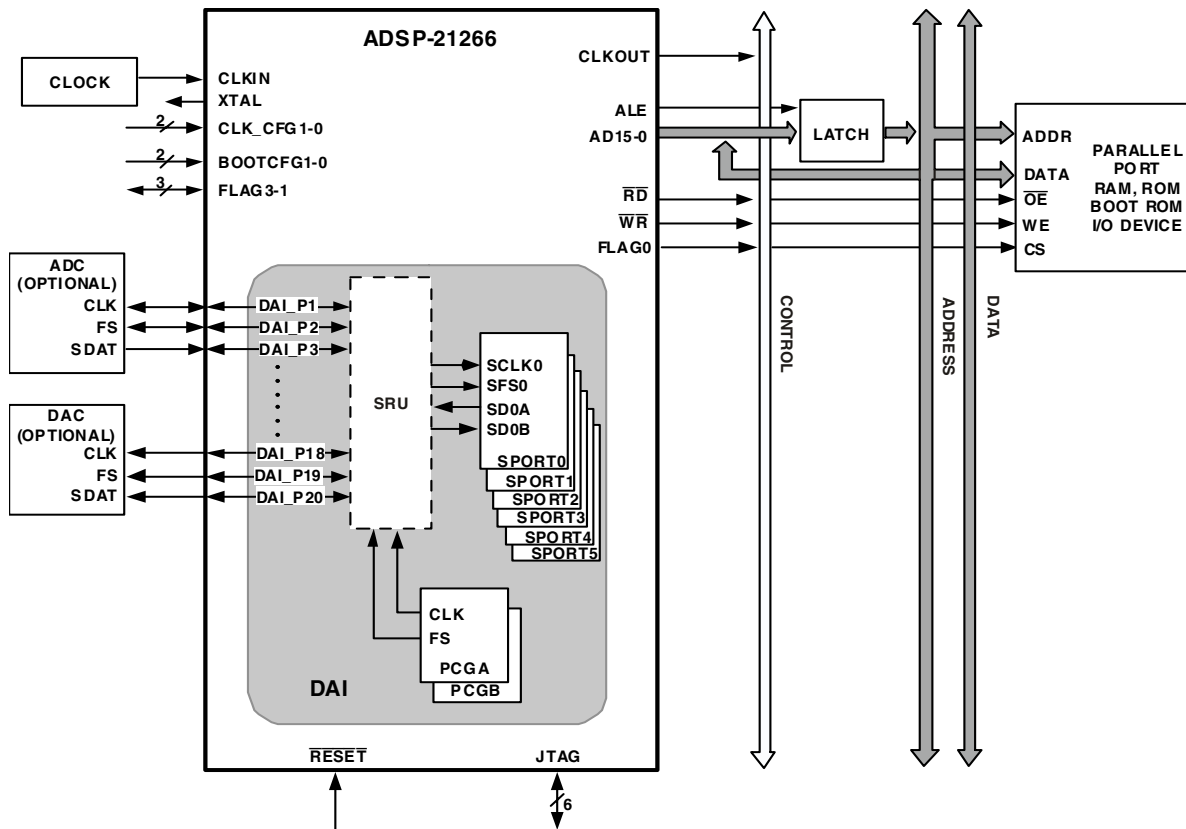

Figure 2. ADSP-21266 System Sample Configuration

Independent, Parallel Computation Units

Within each processing element is a set of computational units. The computational units consist of an arithmetic/logic unit (ALU), multiplier, and shifter. These units perform all operations in a single cycle. The three units within each processing element are arranged in parallel, maximizing computational throughput. Single multifunction instructions execute parallel ALU and multiplier operations. In SIMD mode, the parallel ALU and multiplier operations occur in both processing elements. These computation units support IEEE 32-bit single-precision floating-point, 40-bit extended precision floating-point, and 32-bit fixed-point data formats.

Data Register File

A general-purpose data register file is contained in each processing element. The register files transfer data between the computation units and the data buses, and store intermediate results. These 10-port, 32-register (16 primary, 16 secondary) register files, combined with the ADSP-2126x enhanced Harvard architecture, allow unconstrained data flow between computation units and internal memory. The registers in PEX are referred to as R0-R15 and in PEY as S0-S15.

Single-Cycle Fetch of Instruction and Four Operands

The ADSP-21266 features an enhanced Harvard architecture in which the data memory (DM) bus transfers data and the program memory (PM) bus transfers both instructions and data (see Figure 1 on Page 1). With the ADSP-21266's separate program and data memory buses and on-chip instruction cache, the processor can simultaneously fetch four operands (two over each data bus) and one instruction (from the cache), all in a single cycle.

Instruction Cache

The ADSP-21266 includes an on-chip instruction cache that enables three-bus operation for fetching an instruction and four data values. The cache is selective—only the instructions whose fetches conflict with PM bus data accesses are cached. This cache allows full-speed execution of core, looped operations such as digital filter multiply-accumulates, and FFT butterfly processing.

Data Address Generators with Zero-Overhead Hardware Circular Buffer Support

The ADSP-21266's two data address generators (DAGs) are used for indirect addressing and implementing circular data buffers in hardware. Circular buffers allow efficient programming of delay lines and other data structures required in digital signal processing, and are commonly used in digital filters and

ADSP-21266

Fourier transforms. The two DAGs of the ADSP-21266 contain sufficient registers to allow the creation of up to 32 circular buffers (16 primary register sets, 16 secondary). The DAGs automatically handle address pointer wraparound, reduce overhead, increase performance, and simplify implementation. Circular buffers can start and end at any memory location.

Flexible Instruction Set

The 48-bit instruction word accommodates a variety of parallel operations for concise programming. For example, the ADSP-21266 can conditionally execute a multiply, an add, and a subtract in both processing elements while branching and fetching up to four 32-bit values from memory—all in a single instruction.

ADSP-21266 MEMORY AND I/O INTERFACE FEATURES

The ADSP-21266 adds the following architectural features to the SIMD SHARC family core:

Dual-Ported On-Chip Memory

The ADSP-21266 contains two megabits of internal SRAM and four megabits of internal mask-programmable ROM. Each block can be configured for different combinations of code and data storage (see [ADSP-21266 Memory Map on Page 7](#)). Each memory block is dual-ported for single-cycle, independent accesses by the core processor and I/O processor. The dual-ported memory, in combination with three separate on-chip buses, allows two data transfers from the core and one from the I/O processor, in a single cycle.

The ADSP-21266's SRAM can be configured as a maximum of 64K words of 32-bit data, 128K words of 16-bit data, 42K words of 48-bit instructions (or 40-bit data), or combinations of different word sizes up to two megabits. All of the memory can be accessed as 16-bit, 32-bit, 48-bit, or 64-bit words. A 16-bit floating-point storage format is supported that effectively doubles the amount of data that may be stored on-chip. Conversion between the 32-bit floating-point and 16-bit floating-point formats is performed in a single instruction. While each memory block can store combinations of code and data, accesses are most efficient when one block stores data using the DM bus for transfers, and the other block stores instructions and data using the PM bus for transfers.

Using the DM bus and PM buses, with one dedicated to each memory block assures single-cycle execution with two data transfers. In this case, the instruction must be available in the cache.

DMA Controller

The ADSP-21266's on-chip DMA controller allows zero-overhead data transfers without processor intervention. The DMA controller operates independently and invisibly to the processor core, allowing DMA operations to occur while the core is simultaneously executing its program instructions. DMA transfers can occur between the ADSP-21266's internal memory and its serial ports, the SPI-compatible (Serial Peripheral Interface) port, the IDP (Input Data Port), Parallel Data Acquisition Port

(PDAP), or the parallel port. Twenty-two channels of DMA are available on the ADSP-21266—one for the SPI interface, 12 via the serial ports, eight via the Input Data Port, and one via the processor's parallel port. Programs can be downloaded to the ADSP-21266 using DMA transfers. Other DMA features include interrupt generation upon completion of DMA transfers, and DMA chaining for automatic linked DMA transfers.

Digital Audio Interface (DAI)

The Digital Audio Interface (DAI) provides the ability to connect various peripherals to any of the SHARCs DAI pins (DAI_P[20:1]).

Connections are made using the Signal Routing Unit (SRU), shown in the block diagram on [Page 1](#).

The SRU is a matrix routing unit (or group of multiplexers) that enables the peripherals provided by the DAI to be interconnected under software control. This allows easy use of the DAI associated peripherals for a much wider variety of applications by using a larger set of algorithms than is possible with nonconfigurable signal paths.

The DAI also includes six serial ports, two precision clock generators (PCGs), an input data port (IDP), six flag outputs and six flag inputs, and three timers. The IDP provides an additional input path to the ADSP-21266 core, configurable as either eight channels of I²S or serial data, or as seven channels plus a single 20-bit wide synchronous parallel data acquisition port. Each data channel has its own DMA channel that is independent from the ADSP-21266's serial ports.

For complete information on using the DAI, see the *ADSP-2126x SHARC DSP Peripherals Manual*.

Serial Ports

The ADSP-21266 features six full duplex synchronous serial ports that provide an inexpensive interface to a wide variety of digital and mixed-signal peripheral devices such as the Analog Devices AD183x family of audio codecs, ADCs, and DACs. The serial ports are made up of two data lines, a clock, and frame sync. The data lines can be programmed to either transmit or receive and each data line has its own dedicated DMA channel.

Serial ports are enabled via 12 programmable and simultaneous receive or transmit pins that support up to 24 transmit or 24 receive channels of audio data when all six SPORTs are enabled, or six full duplex TDM streams of 128 channels per frame.

The serial ports operate at up to one-quarter of the DSP core clock rate, providing each with a maximum data rate of 50M bits/s for a 200 MHz core and 37.5M bits/s for a 150 MHz core. Serial port data can be automatically transferred to and from on-chip memory via a dedicated DMA. Each of the serial ports can work in conjunction with another serial port to provide TDM support. One SPORT provides two transmit signals while the other SPORT provides the two receive signals. The frame sync and clock are shared.

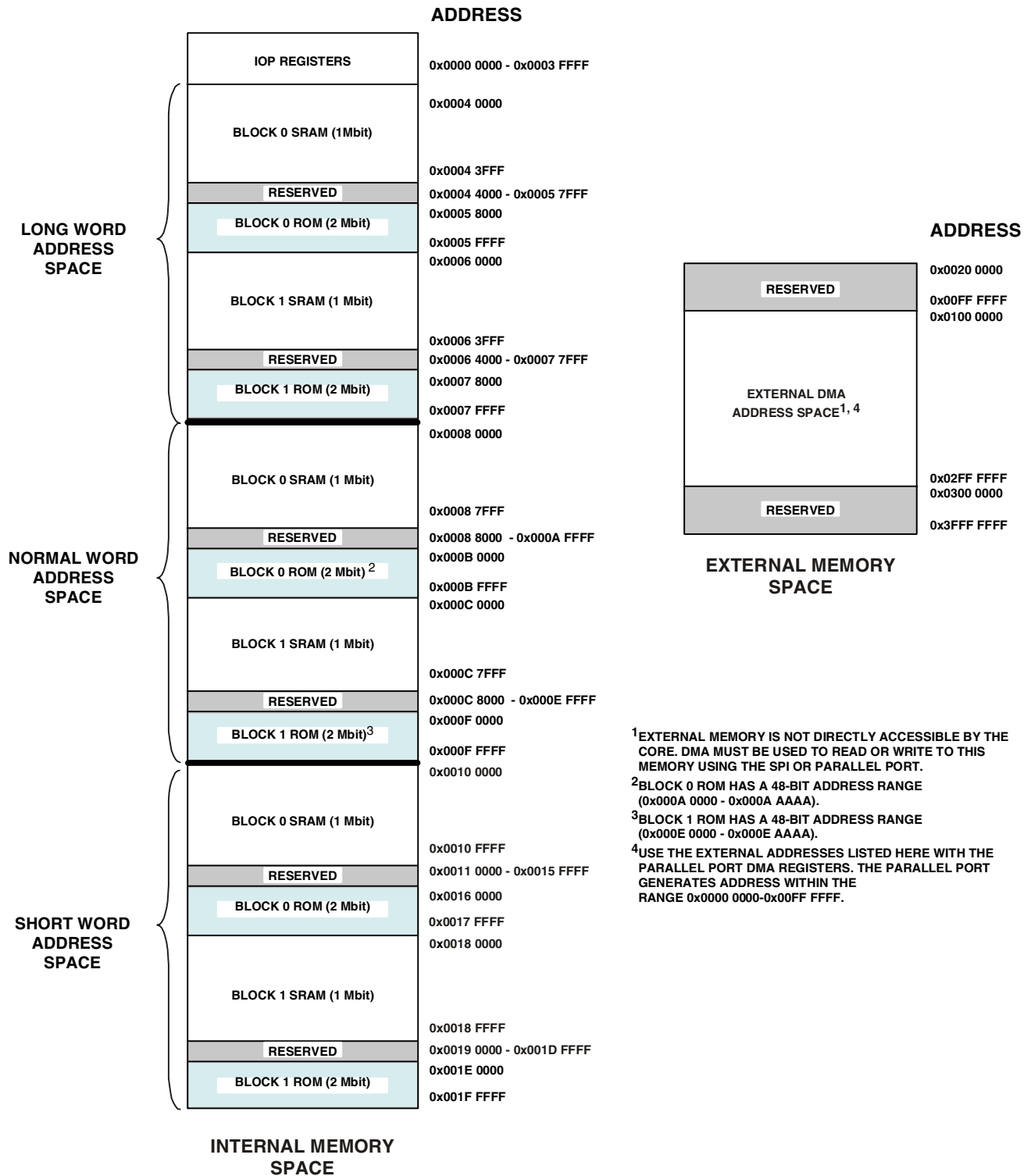

¹EXTERNAL MEMORY IS NOT DIRECTLY ACCESSIBLE BY THE CORE. DMA MUST BE USED TO READ OR WRITE TO THIS MEMORY USING THE SPI OR PARALLEL PORT.
²BLOCK 0 ROM HAS A 48-BIT ADDRESS RANGE (0x000A 0000 - 0x000A AAAA).
³BLOCK 1 ROM HAS A 48-BIT ADDRESS RANGE (0x000E 0000 - 0x000E AAAA).
⁴USE THE EXTERNAL ADDRESSES LISTED HERE WITH THE PARALLEL PORT DMA REGISTERS. THE PARALLEL PORT GENERATES ADDRESS WITHIN THE RANGE 0x0000 0000-0x00FF FFFF.

Figure 3. ADSP-21266 Memory Map

ADSP-21266

Serial ports operate in four modes:

- Standard DSP serial mode
- Multichannel (TDM) mode
- I²S mode
- Left-justified sample pair mode

Left-justified sample pair mode is a mode where in each frame sync cycle two samples of data are transmitted/received—one sample on the high segment of the frame sync, the other on the low segment of the frame sync. Programs have control over various attributes of this mode.

Each of the serial ports supports the left-justified sample pair and I²S protocols (I²S is an industry-standard interface commonly used by audio codecs, ADCs and DACs), with two data pins, allowing four left-justified sample pair or I²S channels (using two stereo devices) per serial port, with a maximum of up to 24 audio channels. The serial ports permit little-endian or big-endian transmission formats and word lengths selectable from 3 bits to 32 bits. For the left-justified sample pair and I²S modes, data-word lengths are selectable between 8 bits and 32 bits. Serial ports offer selectable synchronization and transmit modes as well as optional μ -law or A-law companding selection on a per channel basis. Serial port clocks and frame syncs can be internally or externally generated.

Serial Peripheral (Compatible) Interface

Serial Peripheral Interface (SPI) is an industry-standard synchronous serial link, enabling the ADSP-21266 SPI-compatible port to communicate with other SPI-compatible devices. SPI is an interface consisting of two data pins, one device select pin, and one clock pin. It is a full-duplex synchronous serial interface, supporting both master and slave modes. The SPI port can operate in a multimaster environment by interfacing with up to four other SPI compatible devices, either acting as a master or slave device. The ADSP-21266 SPI-compatible peripheral implementation also features programmable baud rates up to 37.5 MHz, clock phases, and polarities. The ADSP-21266 SPI-compatible port uses open drain drivers to support a multimaster configuration and to avoid data contention.

Parallel Port

The Parallel Port provides interfaces to SRAM and peripheral devices. The multiplexed address and data pins (AD15-0) can access 8-bit devices with up to 24 bits of address, or 16-bit devices with up to 16 bits of address. In either mode, 8- or 16-bit, the maximum data transfer rate is one-third the core clock speed. As an example, a clock rate of 200 MHz, is equivalent to 66M Bytes/sec, and a clock rate of 150 MHz is equivalent to 50M Bytes/sec.

DMA transfers are used to move data to and from internal memory. Access to the core is also facilitated through the parallel port register read/write functions. The RD, WR, and ALE (Address Latch Enable) pins are the control pins for the parallel port.

Timers

The ADSP-21266 has a total of four timers: a core timer able to generate periodic software interrupts, and three general-purpose timers that can generate periodic interrupts and be independently set to operate in one of three modes:

- Pulse Waveform Generation mode
- Pulse Width Count/Capture mode
- External Event Watchdog mode

The core timer can be configured to use FLAG3 as a Timer Expired output signal, and each general-purpose timer has one bidirectional pin and four registers that implement its mode of operation: a 6-bit configuration register, a 32-bit count register, a 32-bit period register, and a 32-bit pulse width register. A single control and status register enables or disables all three general-purpose timers independently.

ROM Based Security

The ADSP-21266 has a ROM security feature that provides hardware support for securing user software code by preventing unauthorized reading from the internal code when enabled. When using this feature, the DSP does not boot-load any external code, executing exclusively from internal SRAM/ROM. Additionally, the DSP is not freely accessible via the JTAG port. Instead, a unique 64-bit key, which must be scanned in through the JTAG or Test Access Port, will be assigned to each customer. The device will ignore a wrong key. Emulation features and external boot modes are only available after the correct key is scanned.

Program Booting

The internal memory of the ADSP-21266 boots at system power-up from an 8-bit EPROM via the parallel port, an SPI master, an SPI slave, or an internal boot. Booting is determined by the Boot Configuration (BOOTCFG1-0) pins. Selection of the boot source is controlled via the SPI as either a master or slave device, or it can immediately begin executing from ROM.

Phase-Locked Loop

The ADSP-21266 uses an on-chip Phase-Locked Loop (PLL) to generate the internal clock for the core. On power-up, the CLKCFG1-0 pins are used to select ratios of 16:1, 8:1, and 3:1. After booting, numerous other ratios can be selected via software control. The ratios are made up of software configurable numerator values from 1 to 32 and software configurable divisor values of 1, 2, 4, 8, and 16.

Power Supplies

The ADSP-21266 has separate power supply connections for the internal (V_{DDINT}), external (V_{DDEXT}), and analog (A_{VDD}/A_{VSS}) power supplies. The internal and analog supplies must meet the 1.2 V requirement. The external supply must meet the 3.3 V requirement. All external supply pins must be connected to the same power supply.

Note that the analog supply (A_{VDD}) powers the ADSP-21266's clock generator PLL. To produce a stable clock, programs should provide an external circuit to filter the power input to

the A_{VDD} pin. Place the filter as close as possible to the pin. For an example circuit, see Figure 4. To prevent noise coupling, use a wide trace for the analog ground (A_{VSS}) signal and install a decoupling capacitor as close as possible to the pin. Note that the A_{VSS} and A_{VDD} pins specified in Figure 4 are inputs to the DSP and not the analog ground plane on the board.

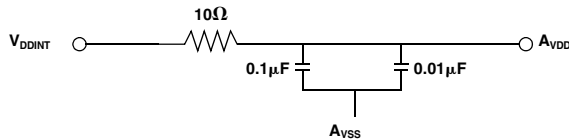

Figure 4. Analog Power (A_{VDD}) Filter Circuit

TARGET BOARD JTAG EMULATOR CONNECTOR

Analog Devices DSP Tools product line of JTAG emulators uses the IEEE 1149.1 JTAG test access port of the ADSP-21266 processor to monitor and control the target board processor during emulation. Analog Devices DSP Tools product line of JTAG emulators provides emulation at full processor speed, allowing inspection and modification of memory, registers, and processor stacks. The processor's JTAG interface ensures that the emulator will not affect target system loading or timing.

For complete information on Analog Devices' SHARC DSP Tools product line of JTAG emulator operation, see the appropriate emulator hardware user's guide.

DEVELOPMENT TOOLS

The ADSP-21266 is supported by a complete automotive reference design and development board as well as by a complete home audio reference design board available from Analog Devices. These boards implement complete audio decoding and post processing algorithms that are factory programmed into the ROM space of the ADSP-21266. SIMD optimized libraries consume less processing resources, which results in more available processing power for custom proprietary features.

The nonvolatile memory of the ADSP-21266 can be configured to contain a combination of Dolby Digital, Dolby Pro Logic, Dolby Pro Logic II, Dolby Pro Logic IIx, DTSES, DTS 96/24, and Neo:6. Multiple S/PDIF and analog I/Os are provided to maximize end system flexibility.

The ADSP-21266 is also supported with a complete set of CROSSCORE™ software and hardware development tools, including Analog Devices emulators and VisualDSP++™ development environment. The same emulator hardware that supports other SHARC processors also fully emulates the ADSP-21266.

The VisualDSP++ project management environment lets programmers develop and debug an application. This environment includes an easy to use assembler (which is based on an algebraic syntax), an archiver (librarian/library builder), a linker, a loader, a cycle-accurate instruction-level simulator, a C/C++ compiler, and a C/C++ runtime library that includes DSP and

mathematical functions. A key point for these tools is C/C++ code efficiency. The compiler has been developed for efficient translation of C/C++ code to DSP assembly. The ADSP-21266 SHARC DSP has architectural features that improve the efficiency of compiled C/C++ code.

The VisualDSP++ debugger has a number of important features. Data visualization is enhanced by a plotting package that offers a significant level of flexibility. This graphical representation of user data enables the programmer to quickly determine the performance of an algorithm. As algorithms grow in complexity, this capability can have increasing significance on the designer's development schedule, increasing productivity. Statistical profiling enables the programmer to nonintrusively poll the processor as it is running the program. This feature, unique to VisualDSP++, enables the software developer to passively gather important code execution metrics without interrupting the real-time characteristics of the program. Essentially, the developer can identify bottlenecks in software quickly and efficiently. By using the profiler, the programmer can focus on those areas in the program that impact performance and take corrective action.

Debugging both C/C++ and assembly programs with the VisualDSP++ debugger, programmers can:

- View mixed C/C++ and assembly code (interleaved source and object information)
- Insert breakpoints
- Set conditional breakpoints on registers, memory, and stacks
- Trace instruction execution
- Perform linear or statistical profiling of program execution
- Fill, dump, and graphically plot the contents of memory
- Perform source level debugging
- Create custom debugger windows

The VisualDSP++ IDDE lets programmers define and manage DSP software development. Its dialog boxes and property pages let programmers configure and manage all of the SHARC development tools, including the color syntax highlighting in the VisualDSP++ editor. This capability permits programmers to:

- Control how the development tools process inputs and generate outputs
- Maintain a one-to-one correspondence with the tool's command line switches

The VisualDSP++ Kernel (VDK) incorporates scheduling and resource management tailored specifically to address the memory and timing constraints of DSP programming. These capabilities enable engineers to develop code more effectively, eliminating the need to start from the very beginning when developing new application code. The VDK features include Threads, Critical and Unscheduled regions, Semaphores, Events, and Device flags. The VDK also supports Priority-based, Preemptive, Cooperative, and Time-Sliced scheduling

approaches. In addition, the VDK was designed to be scalable. If the application does not use a specific feature, the support code for that feature is excluded from the target system.

Because the VDK is a library, a developer can decide whether to use it or not. The VDK is integrated into the VisualDSP++ development environment, but can also be used via standard command line tools. When the VDK is used, the development environment assists the developer with many error-prone tasks and assists in managing system resources, automating the generation of various VDK based objects, and visualizing the system state, when debugging an application that uses the VDK.

VisualDSP++ Component Software Engineering (VCSE) is Analog Devices technology for creating, using, and reusing software components (independent modules of substantial functionality) to quickly and reliably assemble software applications. Download components from the Web and drop them into the application. Publish component archives from within VisualDSP++. VCSE supports component implementation in C/C++ or assembly language.

Use the Expert Linker to visually manipulate the placement of code and data on the embedded system. View memory utilization in a color-coded graphical form, easily move code and data to different areas of the DSP or external memory with the drag of the mouse, examine run time stack and heap usage. The Expert Linker is fully compatible with the existing Linker Definition File (LDF), allowing the developer to move between the graphical and textual environments.

In addition to the software and hardware development tools available from Analog Devices, third parties provide a wide range of tools supporting the SHARC processor family. Hardware tools include SHARC processor PC plug-in cards. Third party software tools include DSP libraries, real-time operating systems, and block diagram design tools.

DESIGNING AN EMULATOR-COMPATIBLE DSP BOARD (TARGET)

The Analog Devices family of emulators are tools that every DSP developer needs to test and debug hardware and software systems. Analog Devices has supplied an IEEE 1149.1 JTAG Test Access Port (TAP) on each JTAG DSP. Nonintrusive in-circuit emulation is assured by the use of the processor's JTAG interface—the emulator does not affect target system loading or timing. The emulator uses the TAP to access the internal features of the DSP, allowing the developer to load code, set breakpoints, observe variables, observe memory, and examine registers. The DSP must be halted to send data and commands, but once an operation has been completed by the emulator, the DSP system is set running at full speed with no impact on system timing.

To use these emulators, the target board must include a header that connects the DSP's JTAG port to the emulator.

For details on target board design issues including mechanical layout, single processor connections, multiprocessor scan chains, signal buffering, signal termination, and emulator pod logic, see the *EE-68: Analog Devices JTAG Emulation Technical Reference* on the Analog Devices website (www.analog.com)—use site search on “EE-68.” This document is updated regularly to keep pace with improvements to emulator support.

ADDITIONAL INFORMATION

This data sheet provides a general overview of the ADSP-21266 architecture and functionality. For detailed information on the ADSP-2126x family core architecture and instruction set, refer to the *ADSP-2126x DSP Core Manual* and the *ADSP-21160 SHARC DSP Instruction Set Reference*.

PIN FUNCTION DESCRIPTIONS

ADSP-21266 pin definitions are listed below. Inputs identified as synchronous (S) must meet timing requirements with respect to CLKIN (or with respect to TCK for TMS, TDI). Inputs identified as asynchronous (A) can be asserted asynchronously to CLKIN (or to TCK for TRST). Tie or pull unused inputs to V_{DDEXT} or GND, except for the following:

- DAI_Px, SPICLK, MISO, MOSI, \overline{EMU} , TMS, \overline{TRST} , TDI and AD15-0 (NOTE: These pins have internal pull-up resistors.)

The following symbols appear in the Type column of Table 2: A = Asynchronous, G = Ground, I = Input, O = Output, P = Power Supply, S = Synchronous, (A/D) = Active Drive, (O/D) = Open Drain, and T = Three-State.

Table 2. Pin Descriptions

Pin	Type	State During and After Reset	Function
AD15-0	I/O/T	Three-state with pull-up enabled. Applies to silicon revision 0.1. Pins are driven low during and after reset. Applies to silicon revision 0.2 only.	Parallel Port Address/Data. The ADSP-21266 parallel port and its corresponding DMA unit output addresses and data for peripherals on these multiplexed pins. The multiplex state is determined by the ALE pin. The parallel port can operate in either 8-bit or 16-bit mode. Each AD pin has a 22.5 k Ω internal pull-up resistor. See Address Data Modes on Page 14 for details of the AD pin operation. For 8-bit mode: ALE is automatically asserted whenever a change occurs in the upper 16 external address bits, A23-8; ALE is used in conjunction with an external latch to retain the values of the A23-8. For 16-bit mode: ALE is automatically asserted whenever a change occurs in the address bits, A15-0; ALE is used in conjunction with an external latch to retain the values of the A15-0. To use these pins as flags (FLAG15-0) set (=1) Bit 20 of the SYSCTL register and disable the parallel port. See Table 3 on Page 14 for a list of how the AD15-0 pins map to the flag pins. When used as an input, the IDP Channel 0 can use these pins for parallel input data.
\overline{RD}	O	Output only, driven high ¹	Parallel Port Read Enable. \overline{RD} is asserted low whenever the DSP reads 8-bit or 16-bit data from an external memory device. When AD15-0 are flags, this pin remains deasserted.
\overline{WR}	O	Output only, driven high ¹	Parallel Port Write Enable. \overline{WR} is asserted low whenever the DSP writes 8-bit or 16-bit data to an external memory device. When AD15-0 are flags, this pin remains deasserted.
ALE	O	Output only, driven low ¹	Parallel Port Address Latch Enable. ALE is asserted whenever the DSP drives a new address on the parallel port address pin. On reset, ALE is active high. However, it can be reconfigured using software to be active low. When AD15-0 are flags, this pin remains deasserted.
FLAG3-0	I/O/A	Three-state	Flag Pins. Each FLAG pin is configured via control bits as either an input or output. As an input, it can be tested as a condition. As an output, it can be used to signal external peripherals. These pins can be used as an SPI interface slave select output during SPI mastering. These pins are also multiplexed with the \overline{IRQx} and the TIMEXP signals. In SPI master boot mode, FLAG0 is the slave select pin that must be connected to an SPI EPROM. FLAG0 is configured as a slave select during SPI master boot. When Bit 16 is set (=1) in the SYSCTL register, FLAG0 is configured as $\overline{IRQ0}$. When Bit 17 is set (=1) in the SYSCTL register, FLAG1 is configured as $\overline{IRQ1}$. When Bit 18 is set (=1) in the SYSCTL register, FLAG2 is configured as $\overline{IRQ2}$. When Bit 19 is set (=1) in the SYSCTL register, FLAG3 is configured as TIMEXP, which indicates that the system timer has expired.

ADSP-21266

Table 2. Pin Descriptions (Continued)

Pin	Type	State During and After Reset	Function
DAI_P20-1	I/O/T	Three-state with programmable pull-up	Digital Audio Interface Pins. These pins provide the physical interface to the SRU. The SRU configuration registers define the combination of on-chip peripheral inputs or outputs connected to the pin and to the pin's output enable. The configuration registers of these peripherals then determine the exact behavior of the pin. Any input or output signal present in the SRU may be routed to any of these pins. The SRU provides the connection from the serial ports, input data port, precision clock generators, and timers to the DAI_P20-1 pins. These pins have internal 22.5 kΩ pull-up resistors which are enabled on reset. These pull-ups can be disabled in the DAI_PIN_PULLUP register.
SPICLK	I/O	Three-state with pull-up enabled	Serial Peripheral Interface Clock Signal. Driven by the master, this signal controls the rate at which data is transferred. The master may transmit data at a variety of baud rates. SPICLK cycles once for each bit transmitted. SPICLK is a gated clock that is active during data transfers, only for the length of the transferred word. Slave devices ignore the serial clock if the slave select input is driven inactive (HIGH). SPICLK is used to shift out and shift in the data driven on the MISO and MOSI lines. The data is always shifted out on one clock edge and sampled on the opposite edge of the clock. Clock polarity and clock phase relative to data are programmable into the SPICLK control register and define the transfer format. SPICLK has a 22.5 kΩ internal pull-up resistor.
$\overline{\text{SPIDS}}$	I	Input only	Serial Peripheral Interface Slave Device Select. An active low signal used to select the DSP as an SPI slave device. This input signal behaves like a chip select, and is provided by the master device for the slave devices. In multimaster mode the DSP's $\overline{\text{SPIDS}}$ signal can be driven by a slave device to signal to the DSP (as SPI master) that an error has occurred, as some other device is also trying to be the master device. If asserted low when the device is in master mode, it is considered a multimaster error. For a single master, multiple-slave configuration where flag pins are used, this pin must be tied or pulled high to V_{DDEXT} on the master device. For ADSP-21266 to ADSP-21266 SPI interaction, any of the master ADSP-21266's flag pins can be used to drive the $\overline{\text{SPIDS}}$ signal on the ADSP-21266 SPI slave device.
MOSI	I/O (O/D)	Three-state with pull-up enabled	SPI Master Out Slave In. If the ADSP-21266 is configured as a master, the MOSI pin becomes a data transmit (output) pin, transmitting output data. If the ADSP-21266 is configured as a slave, the MOSI pin becomes a data receive (input) pin, receiving input data. In an ADSP-21266 SPI interconnection, the data is shifted out from the MOSI output pin of the master and shifted into the MOSI input(s) of the slave(s). MOSI has a 22.5 kΩ internal pull-up resistor.
MISO	I/O (O/D)	Three-state with pull-up enabled	SPI Master In Slave Out. If the ADSP-21266 is configured as a master, the MISO pin becomes a data receive (input) pin, receiving input data. If the ADSP-21266 is configured as a slave, the MISO pin becomes a data transmit (output) pin, transmitting output data. In an ADSP-21266 SPI interconnection, the data is shifted out from the MISO output pin of the slave and shifted into the MISO input pin of the master. MISO has a 22.5 kΩ internal pull-up resistor. MISO can be configured as O/D by setting the OPD bit in the SPICLK register. Note: Only one slave is allowed to transmit data at any given time. To enable broadcast transmission to multiple SPI slaves, the DSP's MISO pin may be disabled by setting (=1) Bit 5 (DMISO) of the SPICLK register.
BOOTCFG1-0	I	Input only	Boot Configuration Select. Selects the boot mode for the DSP. The BOOTCFG pins must be valid before reset is asserted. See Table 4 on Page 14 for a description of the boot modes.

Table 2. Pin Descriptions (Continued)

Pin	Type	State During and After Reset	Function
CLKIN	I	Input only	Local Clock In. Used in conjunction with XTAL. CLKIN is the ADSP-21266 clock input. It configures the ADSP-21266 to use either its internal clock generator or an external clock source. Connecting the necessary components to CLKIN and XTAL enables the internal clock generator. Connecting the external clock to CLKIN while leaving XTAL unconnected configures the ADSP-21266 to use the external clock source such as an external clock oscillator. The core is clocked either by the PLL output or this clock input depending on the CLKCFG1-0 pin settings. CLKIN may not be halted, changed, or operated below the specified frequency.
XTAL	O	Output only ²	Crystal Oscillator Terminal. Used in conjunction with CLKIN to drive an external crystal.
CLKCFG1-0	I	Input only	Core/CLKIN Ratio Control. These pins set the start up clock frequency. See Table 5 on Page 14 for a description of the clock configuration modes. Note that the operating frequency can be changed by programming the PLL multiplier and divider in the PMCTL register at any time after the core comes out of reset.
$\overline{\text{RSTOUT}}/\text{CLKOUT}$	O	Output only	Reset Out/Local Clock Out. Drives out the core reset signal to an external device. CLKOUT can also be configured as a reset out pin ($\overline{\text{RSTOUT}}$). The functionality can be switched between the PLL output clock and reset out by setting Bit 12 of the PMCTL register. The default is reset out.
$\overline{\text{RESET}}$	I/A	Input only	Processor Reset. Resets the ADSP-21266 to a known state. Upon deassertion, there is a 4096 CLKIN cycle latency for the PLL to lock. After this time, the core begins program execution from the hardware reset vector address. The $\overline{\text{RESET}}$ input must be asserted (low) at power-up.
TCK	I	Input only ³	Test Clock (JTAG). Provides a clock for JTAG boundary scan. TCK must be asserted (pulsed low) after power-up or held low for proper operation of the ADSP-21266.
TMS	I/S	Three-state with pull-up enabled	Test Mode Select (JTAG). Used to control the test state machine. TMS has a 22.5 k Ω internal pull-up resistor.
TDI	I/S	Three-state with pull-up enabled	Test Data Input (JTAG). Provides serial data for the boundary scan logic. TDI has a 22.5 k Ω internal pull-up resistor.
TDO	O	Three-state ⁴	Test Data Output (JTAG). Serial scan output of the boundary scan path.
$\overline{\text{TRST}}$	I/A	Three-state with pull-up enabled	Test Reset (JTAG). Resets the test state machine. $\overline{\text{TRST}}$ must be asserted (pulsed low) after power-up or held low for proper operation of the ADSP-21266. $\overline{\text{TRST}}$ has a 22.5 k Ω internal pull-up resistor.
$\overline{\text{EMU}}$	O (O/D)	Three-state with pull-up enabled	Emulation Status. Must be connected to the ADSP-21266 Analog Devices DSP Tools product line of JTAG emulators target board connector only. $\overline{\text{EMU}}$ has a 22.5 k Ω internal pull-up resistor.
V _{DDINT}	P		Core Power Supply. Nominally +1.2 V dc and supplies the DSP's core processor (13 pins on the BGA package, 32 pins on the LQFP package).
V _{DDEXT}	P		I/O Power Supply. Nominally +3.3 V dc (6 pins on the BGA package, 10 pins on the LQFP package).
A _{VDD}	P		Analog Power Supply. Nominally +1.2 V dc and supplies the DSP's internal PLL (clock generator). This pin has the same specifications as V _{DDINT} , except that added filtering circuitry is required. For more information, see Power Supplies on Page 8.
A _{VSS}	G		Analog Power Supply Return.
GND	G		Power Supply Return. (54 pins on the BGA package, 39 pins on the LQFP package).

¹ $\overline{\text{RD}}$, $\overline{\text{WR}}$, and ALE are continuously driven by the DSP and will not be three-stated.

² Output only is a three-state driver with its output path always enabled.

³ Input only is a three-state driver with both output paths.

⁴ Three-state is a three-state driver.

ADSP-21266

ADDRESS DATA PINS AS FLAGS

To use these pins as flags (FLAG15-0) set (=1) Bit 20 of the SYSCCTL register and disable the parallel port.

Table 3. AD[15:0] to FLAG Pin Mapping

AD Pin	Flag Pin
AD0	FLAG8
AD1	FLAG9
AD2	FLAG10
AD3	FLAG11
AD4	FLAG12
AD5	FLAG13
AD6	FLAG14
AD7	FLAG15
AD8	FLAG0
AD9	FLAG1
AD10	FLAG2
AD11	FLAG3
AD12	FLAG4
AD13	FLAG5
AD14	FLAG6
AD15	FLAG7

Boot Modes

Table 4. Boot Mode Selection

BOOTCFG1-0	Booting Mode
00	SPI Slave Boot
01	SPI Master Boot
10	Parallel Port Boot via EPROM
11	Internal Boot Mode (ROM code only)

CORE INSTRUCTION RATE TO CLKIN RATIO MODES

Table 5. Core Instruction Rate/ CLKIN Ratio Selection

CLKCFG1-0	Core to CLKIN Ratio
00	3:1
01	16:1
10	8:1
11	Reserved

ADDRESS DATA MODES

The following table shows the functionality of the AD pins for 8-bit and 16-bit transfers to the parallel port. For 8-bit data transfers, ALE latches address bits A23-A8 when asserted, followed by address bits A7-A0 and data bits D7-D0 when deasserted. For 16-bit data transfers, ALE latches address bits A15-A0 when asserted, followed by data bits D15-D0 when deasserted.

Table 6. Address/Data Mode Selection

EP Data Mode	ALE	AD7-0 Function	AD15-8 Function
8-bit	Asserted	A15-8	A23-16
8-bit	Deasserted	D7-0	A7-0
16-bit	Asserted	A7-0	A15-8
16-bit	Deasserted	D7-0	D15-8

ADSP-21266 SPECIFICATIONS

RECOMMENDED OPERATING CONDITIONS

Parameter ¹		K Grade		Unit
		Min	Max	
V _{DDINT}	Internal (Core) Supply Voltage	1.14	1.26	V
A _{VDD}	Analog (PLL) Supply Voltage	1.14	1.26	V
V _{DDEXT}	External (I/O) Supply Voltage	3.13	3.47	V
V _{IH}	High Level Input Voltage ² , @ V _{DDEXT} = max	2.0	V _{DDEXT} + 0.5	V
V _{IL}	Low Level Input Voltage ² @ V _{DDEXT} = min	-0.5	+0.8	V
V _{IH_CLKIN}	High Level Input Voltage ³ , @ V _{DDEXT} = max	1.74	V _{DDEXT} + 0.5	V
V _{IL_CLKIN}	Low Level Input Voltage, @ V _{DDEXT} = min	-0.5	+1.28	V
T _{AMB}	Ambient Operating Temperature ^{4, 5}	0	+70	°C

¹ Specifications subject to change without notice.

² Applies to input and bidirectional pins: AD15-0, FLAG3-0, DAI_Px, SPICLK, MOSI, MISO, $\overline{\text{SPIDS}}$, BOOTCFGx, CLKCFGx, $\overline{\text{RESET}}$, TCK, TMS, TDI, $\overline{\text{TRST}}$.

³ Applies to input pin CLKIN.

⁴ See [Thermal Characteristics on Page 38](#) for information on thermal specifications.

⁵ See Engineer-to-Engineer Note (No. 216) for further information.

ELECTRICAL CHARACTERISTICS

Parameter ¹	Test Conditions	Min	Max	Unit
V _{OH}	High Level Output Voltage ²	2.4		V
V _{OL}	Low Level Output Voltage ²		0.4	V
I _{IH}	High Level Input Current ^{4, 5}		10	μA
I _{IL}	Low Level Input Current ⁴		10	μA
I _{ILPU}	Low Level Input Current Pull-Up ⁵		200	μA
I _{OZH}	Three-State Leakage Current ^{6, 7, 8}		10	μA
I _{OZL}	Three-State Leakage Current ⁶		10	μA
I _{OZLPU}	Three-State Leakage Current Pull-Up ⁷		200	μA
I _{DD-INTYP}	Supply Current (Internal) ^{9, 10, 11}		500	mA
A _{IDD}	Supply Current (Analog) ¹²		10	mA
C _{IN}	Input Capacitance ^{13, 14}		4.7	pF

¹ Specifications subject to change without notice.

² Applies to output and bidirectional pins: AD15-0, $\overline{\text{RD}}$, $\overline{\text{WR}}$, ALE, FLAG3-0, DAI_Px, SPICLK, MOSI, MISO, $\overline{\text{EMU}}$, TDO, CLKOUT, XTAL.

³ See [Output Drive Currents on Page 37](#) for typical drive current capabilities.

⁴ Applies to input pins: $\overline{\text{SPIDS}}$, BOOTCFGx, CLKCFGx, TCK, $\overline{\text{RESET}}$, CLKIN.

⁵ Applies to input pins with 22.5 kΩ internal pull-ups: $\overline{\text{TRST}}$, TMS, TDI.

⁶ Applies to three-statable pins: FLAG3-0.

⁷ Applies to three-statable pins with 22.5 kΩ pull-ups: AD15-0, DAI_Px, SPICLK, MISO, MOSI.

⁸ Applies to open-drain output pins: $\overline{\text{EMU}}$, MISO, MOSI.

⁹ Typical internal current data reflects nominal operating conditions.

¹⁰ See Engineer-to-Engineer Note (No. 216) for further information.

¹¹ Characterized, but not tested.

¹² Characterized, but not tested.

¹³ Applies to all signal pins.

¹⁴ Guaranteed, but not tested.

ADSP-21266

ABSOLUTE MAXIMUM RATINGS

Parameter	Rating
Internal (Core) Supply Voltage (V_{DDINT}) ¹	-0.3 V to +1.4 V
Analog (PLL) Supply Voltage (A_{VDD}) ¹	-0.3 V to +1.4 V
External (I/O) Supply Voltage (V_{DDEXT}) ¹	-0.3 V to +3.8 V
Input Voltage -0.5 V to V_{DDEXT} ¹	+ 0.5 V
Output Voltage Swing -0.5 V to V_{DDEXT} ¹	+ 0.5 V
Load Capacitance ¹	200 pF
Storage Temperature Range ¹	-65°C to +150°C
Junction Temperature under Bias	125°C

¹ Stresses greater than those listed above may cause permanent damage to the device. These are stress ratings only; functional operation of the device at these or any other conditions greater than those indicated in the operational sections of this specification is not implied. Exposure to absolute maximum rating conditions for extended periods may affect device reliability.

ESD SENSITIVITY

CAUTION

ESD (electrostatic discharge) sensitive device. Electrostatic charges as high as 4000 V readily accumulate on the human body and test equipment and can discharge without detection. Although the ADSP-21266 features proprietary ESD protection circuitry, permanent damage may occur on devices subjected to high energy electrostatic discharges. Therefore, proper ESD precautions are recommended to avoid performance degradation or loss of functionality.



TIMING SPECIFICATIONS

The ADSP-21266's internal clock (a multiple of CLKIN) provides the clock signal for timing internal memory, processor core, serial ports, and parallel port (as required for read/write strobes in asynchronous access mode). During reset, program the ratio between the DSP's internal clock frequency and external (CLKIN) clock frequency with the CLKCFG1-0 pins. To determine switching frequencies for the serial ports, divide down the internal clock, using the programmable divider control of each port (DIVx for the serial ports).

The ADSP-21266's internal clock switches at higher frequencies than the system input clock (CLKIN). To generate the internal clock, the DSP uses an internal phase-locked loop (PLL). This PLL-based clocking minimizes the skew between the system clock (CLKIN) signal and the DSP's internal clock (the clock source for the parallel port logic and I/O pads).

Note the definitions of various clock periods that are a function of CLKIN and the appropriate ratio control (Table 7 and Table 8).

Table 7. ADSP-21266 CLKOUT and CCLK Clock Generation Operation

Timing Requirements	Description	Calculation
CLKIN	Input Clock	$1/t_{CK}$
CCLK	Core Clock	$1/t_{CCLK}$

Table 8. Clock Periods

Timing Requirements	Description ¹
t_{CK}	CLKIN Clock Period
t_{CCLK}	(Processor) Core Clock Period
t_{SCLK}	Serial Port Clock Period = $(t_{CCLK}) \times SR$
t_{SPICLK}	SPI Clock Period = $(t_{CCLK}) \times SPIR$

¹ where:

SR = serial port-to-core clock ratio (wide range, determined by SPORT CLKDIV)

SPIR = SPI-to-Core Clock Ratio (wide range, determined by SPIBAUD register)

DAL_Px = Serial Port Clock

SPICLK = SPI Clock

Figure 5 shows Core to CLKIN ratios of 3:1, 8:1, and 16:1 with external oscillator or crystal. Note that more ratios are possible and can be set through software using the power management control register (PMCTL). For more information, see the *ADSP-2126x SHARC DSP Core Manual*.

Use the exact timing information given. Do not attempt to derive parameters from the addition or subtraction of others. While addition or subtraction would yield meaningful results for an individual device, the values given in this data sheet reflect statistical variations and worst cases. Consequently, it is not meaningful to add parameters to derive longer times.

See Figure 30 on Page 37 under Test Conditions for voltage reference levels.

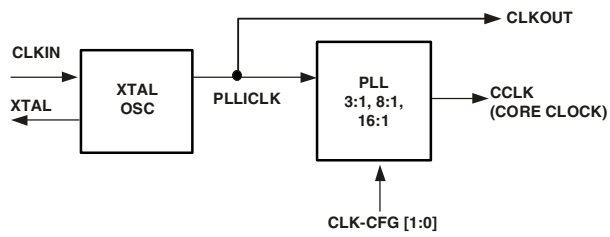

Figure 5. Core Clock and System Clock Relationship to CLKIN

Switching characteristics specify how the processor changes its signals. Circuitry external to the processor must be designed for compatibility with these signal characteristics. Switching characteristics describe what the processor will do in a given circumstance. Use switching characteristics to ensure that any timing requirement of a device connected to the processor (such as memory) is satisfied.

Timing requirements apply to signals that are controlled by circuitry external to the processor, such as the data input for a read operation. Timing requirements guarantee that the processor operates correctly with other devices.

ADSP-21266

Power-Up Sequencing

The timing requirements for DSP startup are given in Table 9.

Table 9. Power-Up Sequencing Timing Requirements (DSP Startup)

Parameter		Min	Max	Unit
<i>Timing Requirements</i>				
t_{RSTVDD}	\overline{RESET} Low Before V_{DDINT}/V_{DDEXT} on	0		ns
$t_{IVDDEVDD}$	V_{DDINT} on before V_{DDEXT}	-50	200	ms
t_{CLKVDD}	CLKIN Valid After V_{DDINT}/V_{DDEXT} Valid ¹	0	200	ms
t_{CLKRST}	CLKIN Valid Before \overline{RESET} Deasserted	10^2		μ s
t_{PLLST}	PLL Control Setup Before \overline{RESET} Deasserted	20^3		μ s
<i>Switching Characteristic</i>				
$t_{CORERST}$	DSP core reset deasserted after \overline{RESET} deasserted	$4096t_{CK}$ ^{4, 5}		

¹ Valid V_{DDINT}/V_{DDEXT} assumes that the supplies are fully ramped to their 1.2 and 3.3 volt rails. Voltage ramp rates can vary from microseconds to hundreds of milliseconds depending on the design of the power supply subsystem.

² Assumes a stable CLKIN signal, after meeting worst-case startup timing of crystal oscillators. Refer to the crystal oscillator manufacturer's data sheet for startup time. Assume a 25 ms maximum oscillator startup time if using the XTAL pin and internal oscillator circuit in conjunction with an external crystal.

³ Based on CLKIN cycles.

⁴ Applies after the power-up sequence is complete. Subsequent resets require a minimum of 4 CLKIN cycles for \overline{RESET} to be held low in order to properly initialize and propagate default states at all I/O pins.

⁵ The 4096 cycle count depends on t_{Srst} specification in Table 11. If setup time is not met, 1 additional CLKIN cycle may be added to the core reset time, resulting in 4097 cycles maximum.

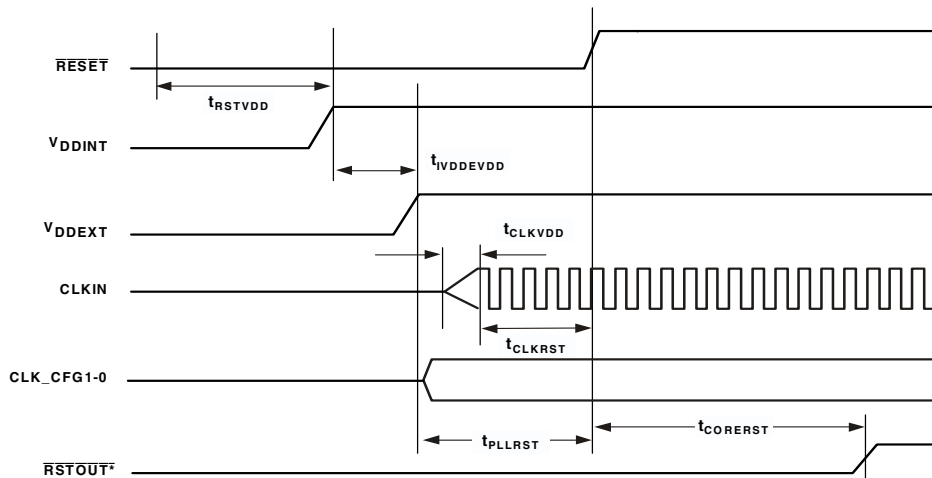

*MULTIPLEXED WITH CLKOUT

Figure 6. Power-Up Sequencing

Clock Input

Table 10. Clock Input

Parameter	150 MHz		200 MHz		Unit
	Min	Max	Min	Max	
<i>Timing Requirements</i>					
t_{CK} CLKIN Period	20 ¹	160 ²	15 ¹	160 ²	ns
t_{CKL} CLKIN Width Low	7.5 ¹	80 ²	6 ¹	80 ²	ns
t_{CKH} CLKIN Width High	7.5 ¹	80 ²	6 ¹	80 ²	ns
t_{CKRF} CLKIN Rise/Fall (0.4 V – 2.0 V)		3		3	ns
t_{CCLK} CCLK Period ³	6.66	10	5	10	ns

¹ Applies only for CLKCFG1-0 = 00 and default values for PLL control bits in PMCTL.

² Applies only for CLKCFG1-0 = 01 and default values for PLL control bits in PMCTL.

³ Any changes to PLL control bits in the PMCTL register must meet core clock timing specification t_{CCLK} .

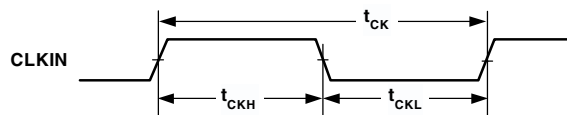
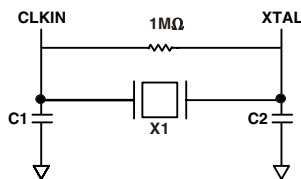

Figure 7. Clock Input

Clock Signals

The ADSP-21266 can use an external clock or a crystal. See CLKIN pin description. The programmer can configure the ADSP-21266 to use its internal clock generator by connecting the necessary components to CLKIN and XTAL. Figure 8 shows the component connections used for a crystal operating in fundamental mode. Note that the 200 MHz clock rate is achieved using a 12.5 MHz crystal and a PLL multiplier ratio 16:1 (CCLK:CLKIN)



NOTE: C1 AND C2 ARE SPECIFIC TO CRYSTAL SPECIFIED FOR X1. CONTACT CRYSTAL MANUFACTURER FOR DETAILS. CRYSTAL SELECTION MUST COMPLY WITH CLKCFG1-0 = 10 OR = 01.

Figure 8. 150 MHz or 200 MHz Operation with a 12.5 MHz Fundamental Mode Crystal

ADSP-21266

Reset

Table 11. Reset

Parameter	Min	Max	Unit
<i>Timing Requirements</i>			
t_{WRST} \overline{RESET} Pulse Width Low ¹	$4t_{CK}$		ns
t_{SRST} \overline{RESET} Setup Before CLKIN Low	8		ns

¹ Applies after the power-up sequence is complete. At power-up, the processor's internal phase-locked loop requires no more than 100 μ s while \overline{RESET} is low, assuming stable VDD and CLKIN (not including start-up time of external clock oscillator).

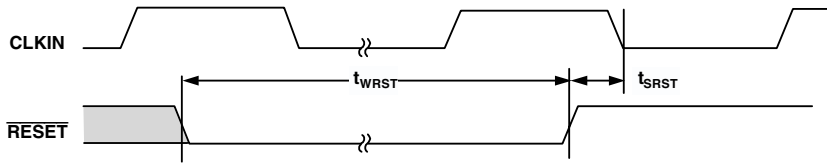

Figure 9. Reset

Interrupts

The following timing specification applies to the FLAG0, FLAG1, and FLAG2 pins when they are configured as $\overline{IRQ0}$, $\overline{IRQ1}$, and $\overline{IRQ2}$ interrupts. Also applies to DAI_P[20:1] pins when configured as interrupts.

Table 12. Interrupts

Parameter	Min	Max	Unit
<i>Timing Requirement</i>			
t_{IPW} \overline{IRQx} Pulse Width	$2 \times t_{CCLK} + 2$		ns

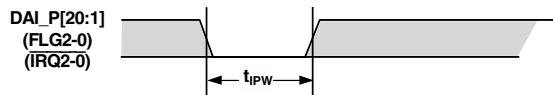

Figure 10. Interrupts

Core Timer

The following timing specification applies to FLAG3 when it is configured as the core timer (CTIMER).

Table 13. Core Timer

Parameter	Min	Max	Unit
<i>Switching Characteristic</i>			
t_{WCTIM} CTIMER Pulse Width	$4 \times t_{CCLK} - 1$		ns

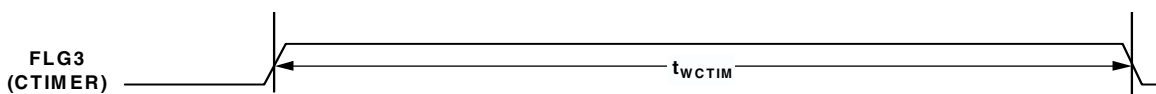

Figure 11. Core Timer

Timer PWM_OUT Cycle Timing

The following timing specification applies to Timer[2:0] in PWM_OUT (pulse width modulation) mode. Timer signals are routed to the DAI_P[20:1] pins through the SRU. Therefore, the timing specifications provided below are valid at the DAI_P[20:1] pins.

Table 14. Timer[2:0] PWM_OUT Timing

Parameter	Min	Max	Unit
<i>Switching Characteristic</i>			
$t_{P_{WMO}}$ Timer[2:0] Pulse Width Output	$2 t_{CCLK} - 1$	$2(2^{31} - 1) t_{CCLK}$	ns

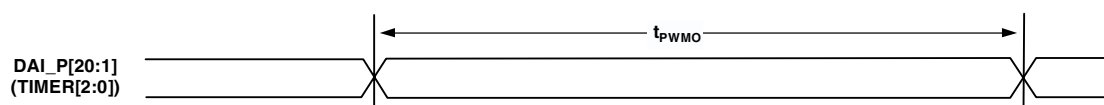

Figure 12. Timer[2:0] PWM_OUT Timing

Timer WDTN_CAP Timing

The following timing specification applies to Timer[2:0] in WDTN_CAP (pulse width count and capture) mode. Timer signals are routed to the DAI_P[20:1] pins through the SRU. Therefore, the timing specifications provided below are valid at the DAI_P[20:1] pins.

Table 15. Timer[2:0] Width Capture Timing

Parameter	Min	Max	Unit
<i>Timing Requirement</i>			
t_{PWI} Timer[2:0] Pulse Width	$2 t_{CCLK}$	$2(2^{31} - 1) t_{CCLK}$	ns

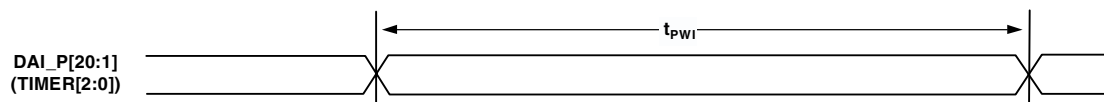

Figure 13. Timer[2:0] Width Capture Timing

ADSP-21266

DAI Pin to Pin Direct Routing

For direct pin connections only (for example DAI_PB01_I to DAI_PB02_O).

Table 16. DAI Pin to Pin Routing

Parameter	Min	Max	Unit
<i>Timing Requirement</i>			
t_{DPIO} Delay DAI Pin Input Valid to DAI Output Valid	1.5	10	ns

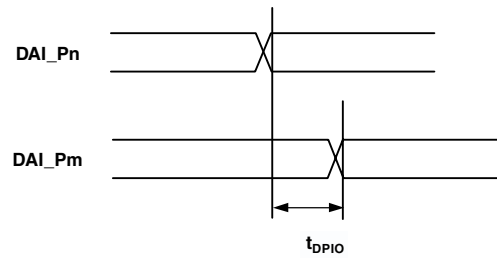

Figure 14. DAI Pin to Pin Direct Routing

Precision Clock Generator (Direct Pin Routing)

This timing is only valid when the SRU is configured such that the Precision Clock Generator (PCG) takes its inputs directly from the DAI pins (via pin buffers) and sends its outputs directly to the DAI pins. For the other cases, where the PCG's

inputs and outputs are not directly routed to/from DAI pins (via pin buffers) there is no timing data available. All timing parameters and switching characteristics apply to external DAI pins (DAI_P07 – DAI_P20).

Table 17. Precision Clock Generator (Direct Pin Routing)

Parameter		Min	Max	Unit
<i>Timing Requirements</i>				
t_{PCGIW}	Input Clock Pulse Width	20		ns
t_{STRIG}	PCG Trigger Setup Before Falling Edge of PCG Input Clock	2		ns
t_{HTRIG}	PCG Trigger Hold After Falling Edge of PCG Input Clock	2		ns
<i>Switching Characteristics</i>				
t_{DPCGIO}	PCG Output Clock and Frame Sync Active Edge Delay After PCG Input Clock Falling Edge	2.5	10	ns
t_{DTRIG}	PCG Output Clock and Frame Sync Delay After PCG Trigger	$2.5 + 2.5 \times t_{PCGOW}$	$10 + 2.5 \times t_{PCGOW}$	ns
t_{PCGOW}	Output Clock Pulse Width	40		ns

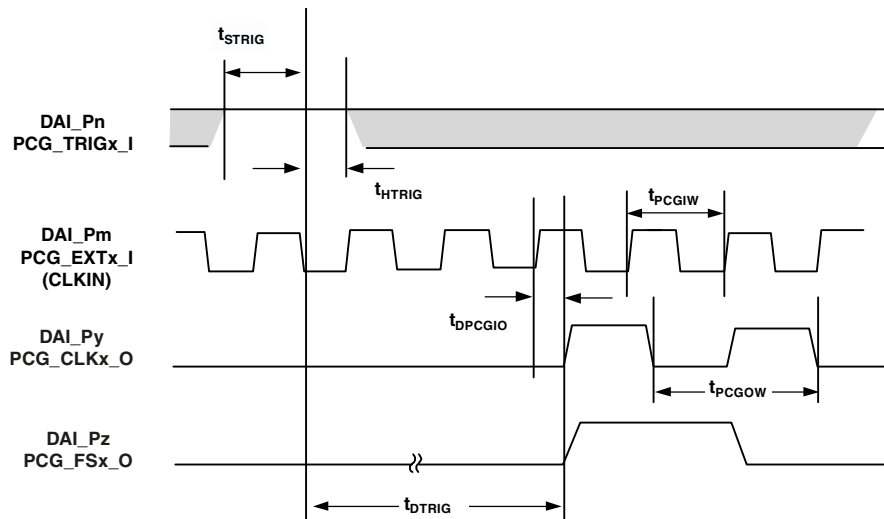

Figure 15. Precision Clock Generator (Direct Pin Routing)

ADSP-21266

Flags

The timing specifications provided below apply to the FLAG[3:0] and DAI_P[20:1] pins, the parallel port, and the serial peripheral interface (SPI). See [Table 2 on Page 11](#) for more information on flag use.

Table 18. Flags

Parameter	Min	Max	Unit
<i>Timing Requirement</i>			
t_{FIPW} FLAG[3:0] IN Pulse Width	$2 \times t_{CCLK} + 3$		ns
<i>Switching Characteristic</i>			
t_{FOPW} FLAG[3:0] OUT Pulse Width	$2 \times t_{CCLK} - 1$		ns

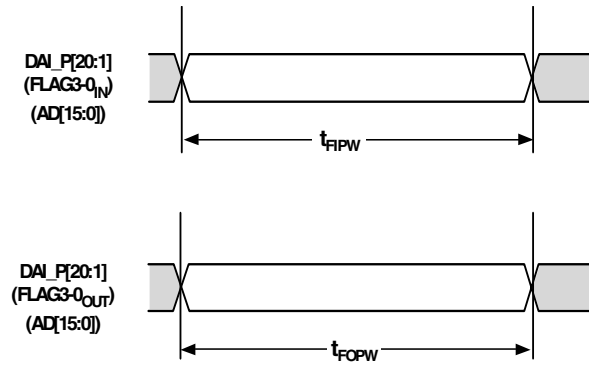

Figure 16. Flags

Memory Read—Parallel Port

Use these specifications for asynchronous interfacing to memories (and memory-mapped peripherals) when the ADSP-21266 is accessing external memory space.

Table 19. 8-Bit Memory Read Cycle

Parameter	Min	Max	Unit
<i>Timing Requirements</i>			
t_{DRS} Address/Data [7:0] Setup Before \overline{RD} High	3.3		ns
t_{DRH} Address/Data [7:0] Hold After \overline{RD} High	0		ns
t_{DAD} Address [15:8] to Data Valid		$D + 0.5 \times t_{CCLK} - 3.5$	ns
<i>Switching Characteristics</i>			
t_{ALEW} ALE Pulse Width	$2 \times t_{CCLK} - 2$		ns
t_{ALERW} ALE Deasserted to Read/Write Asserted	$1 \times t_{CCLK} - 0.5$		ns
t_{ADAS} Address/Data [15:0] Setup Before ALE Deasserted ¹	$2.5 \times t_{CCLK} - 2.0$		ns
t_{ADAH} Address/Data [15:0] Hold After ALE Deasserted ¹	$0.5 \times t_{CCLK} - 0.8$		ns
t_{ALEHZ} ALE Deasserted ¹ to Address/Data[7:0] In High Z	$0.5 \times t_{CCLK} - 0.8$	$0.5 \times t_{CCLK} + 2.0$	ns
t_{RW} \overline{RD} Pulse Width	$D - 2$		ns
t_{ADRH} Address/Data [15:8] Hold After \overline{RD} High	$0.5 \times t_{CCLK} - 1 + H$		ns

D = (Data Cycle Duration) $\times t_{CCLK}$

H = t_{CCLK} (if a hold cycle is specified, else H = 0)

¹ On reset, ALE is an active high cycle. However, it can be reconfigured by software to be active low.

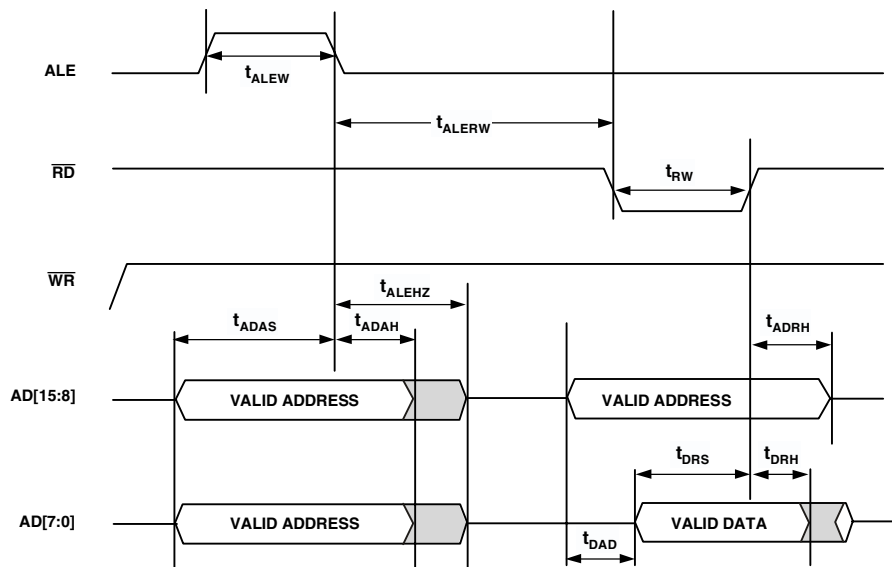

Figure 17. Read Cycle for 8-Bit Memory Timing

ADSP-21266

Table 20. 16-Bit Memory Read Cycle

Parameter		Min	Max	Unit
<i>Timing Requirements</i>				
t_{DRS}	Address/Data [15:0] Setup Before \overline{RD} high	3.3		ns
t_{DRH}	Address/Data [15:0] Hold After \overline{RD} high	0		ns
<i>Switching Characteristics</i>				
t_{ALEW}	ALE Pulse Width	$2 \times t_{CCLK} - 2$		ns
t_{ALERW}	ALE Deasserted to Read/Write Asserted	$1 \times t_{CCLK} - 0.5$		ns
t_{ADAS}	Address/Data [15:0] Setup Before ALE Deasserted ¹	$2.5 \times t_{CCLK} - 2.0$		ns
t_{ADAH}	Address/Data [15:0] Hold After ALE Deasserted ¹	$0.5 \times t_{CCLK} - 0.8$		ns
t_{ALEHZ}	ALE Deasserted ¹ to Address/Data[15:0] In High Z	$0.5 \times t_{CCLK} - 0.8$	$0.5t_{CCLK} + 2.0$	ns
t_{RW}	\overline{RD} Pulse Width	$D - 2$		ns

$D = (\text{Data Cycle Duration}) \times t_{CCLK}$

$H = t_{CCLK}$ (if a hold cycle is specified, else $H = 0$)

¹ On reset, ALE is an active high cycle. However, it can be reconfigured by software to be active low.

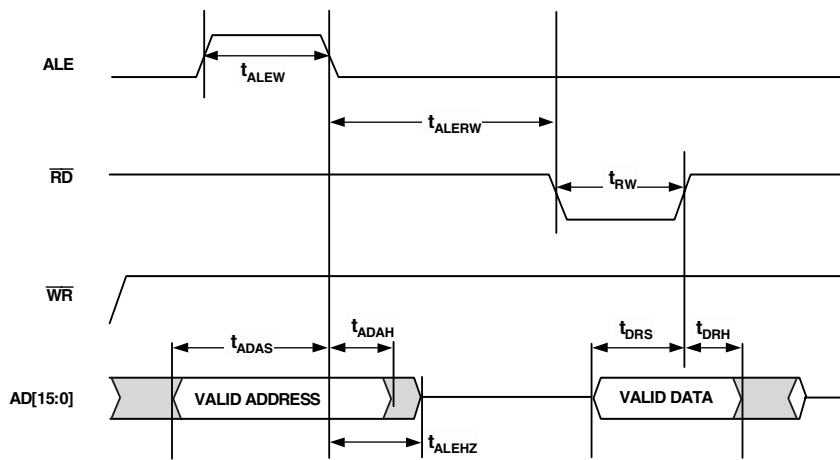

Figure 18. Read Cycle for 16-Bit Memory Timing

Memory Write—Parallel Port

Use these specifications for asynchronous interfacing to memories (and memory-mapped peripherals) when the ADSP-21266 is accessing external memory space.

Table 21. 8-Bit Memory Write Cycle

Parameter	Min	Max	Unit
<i>Switching Characteristics</i>			
t_{ALEW} ALE Pulse Width	$2 \times t_{CCLK} - 2$		ns
t_{ALERW} ALE Deasserted to Read/Write Asserted	$1 \times t_{CCLK} - 0.5$		ns
t_{ADAS} Address/Data [15:0] Setup Before ALE Deasserted ¹	$2.5 \times t_{CCLK} - 2.0$		ns
t_{ADAH} Address/data [15:0] Hold After ALE Deasserted ¹	$0.5 \times t_{CCLK} - 0.8$		ns
t_{WW} \overline{WR} Pulse Width	$D - 2$		ns
t_{ADWL} Address/Data [15:8] to \overline{WR} Low	$0.5 \times t_{CCLK} - 1.5$		ns
t_{ADWH} Address/Data [15:8] Hold After \overline{WR} High	$0.5 \times t_{CCLK} - 1 + H$		ns
t_{ALEHZ} ALE Deasserted ¹ to Address/Data[15:0] In High Z	$0.5 \times t_{CCLK} - 0.8$	$0.5t_{CCLK} + 2.0$	ns
t_{DWS} Address/Data [7:0] Setup Before \overline{WR} High	D		ns
t_{DWH} Address/Data [7:0] Hold After \overline{WR} High	$0.5 \times t_{CCLK} - 1.5 + H$		ns
t_{DAWH} Address/Data to \overline{WR} High	D		ns

D = (Data Cycle Duration) $\times t_{CCLK}$

H = t_{CCLK} (if a hold cycle is specified, else H = 0)

¹ On reset, ALE is an active high cycle. However, it can be reconfigured by software to be active low.

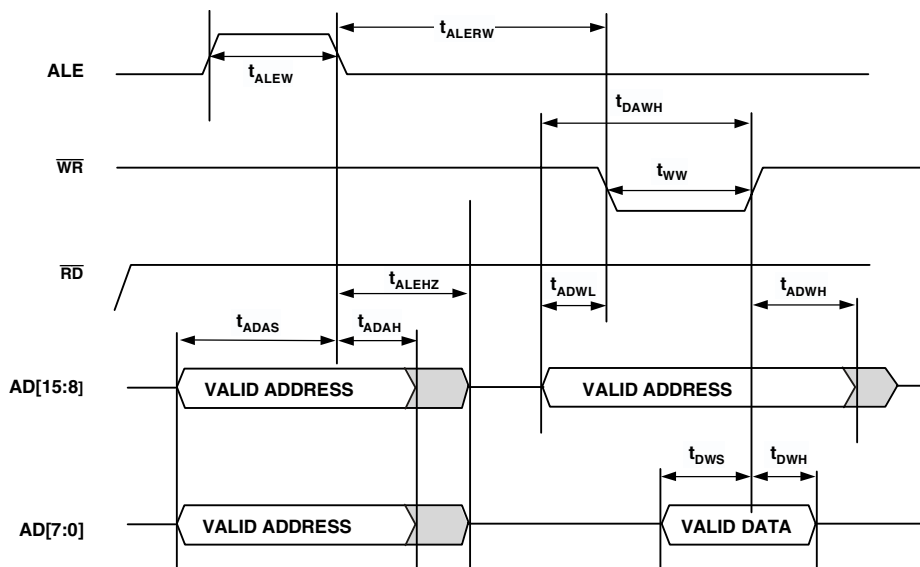

Figure 19. Write Cycle for 8-Bit Memory Timing

ADSP-21266

Table 22. 16-Bit Memory Write Cycle

Parameter		Min	Max	Unit
<i>Switching Characteristics</i>				
t_{ALEW}	ALE Pulse Width	$2 \times t_{CCLK} - 2$		ns
t_{ALERW}	ALE Deasserted to Read/Write Asserted	$1 \times t_{CCLK} - 0.5$		ns
t_{ADAS}	Address/Data [15:0] Setup Before ALE Deasserted ¹	$2.5 \times t_{CCLK} - 2.0$		ns
t_{ADAH}	Address/Data [15:0] Hold After ALE Deasserted ¹	$0.5 \times t_{CCLK} - 0.8$		ns
t_{WW}	\overline{WR} Pulse Width	$D - 2$		ns
t_{ALEHZ}	ALE Deasserted ¹ to Address/Data[15:0] In High Z	$0.5 \times t_{CCLK} - 0.8$	$0.5t_{CCLK} + 2.0$	ns
t_{DWS}	Address/Data [15:0] Setup Before \overline{WR} High	D		ns
t_{DWH}	Address/Data [15:0] Hold After \overline{WR} High	$0.5 \times t_{CCLK} - 1.5 + H$		ns

D = (Data Cycle Duration) $\times t_{CCLK}$

H = t_{CCLK} (if a hold cycle is specified, else H = 0)

¹ On reset, ALE is an active high cycle. However, it can be reconfigured by software to be active low.

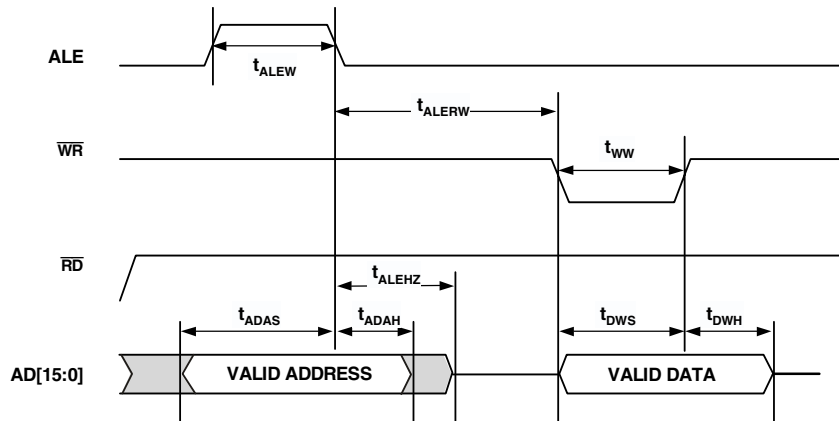

Figure 20. Write Cycle for 16-Bit Memory Timing

Serial Ports

To determine whether communication is possible between two devices at clock speed n , the following specifications must be confirmed: 1) frame sync delay and frame sync setup and hold; 2) data delay and data setup and hold; and 3) SCLK width.

Serial port signals (SCLK, FS, Dx_A/Dx_B) are routed to the DAI_P[20:1] pins using the SRU. Therefore, the timing specifications provided below are valid at the DAI_P[20:1] pins.

Table 23. Serial Ports—External Clock

Parameter	Min	Max	Unit
<i>Timing Requirements</i>			
t _{SFSE} FS Setup Before SCLK (Externally Generated FS in Either Transmit or Receive Mode) ¹	2.5		ns
t _{HFSE} FS Hold After SCLK (Externally Generated FS in Either Transmit or Receive Mode) ¹	2.5		ns
t _{SDRE} Receive Data Setup Before Receive SCLK ¹	2.5		ns
t _{HDRE} Receive Data Hold After SCLK ¹	2.5		ns
t _{SCLKW} SCLK Width	7		ns
t _{SCLK} SCLK Period	20		ns
<i>Switching Characteristics</i>			
t _{DFSE} FS Delay After SCLK (Internally Generated FS in Either Transmit or Receive Mode) ²		7	ns
t _{HOFSE} FS Hold After SCLK (Internally Generated FS in Either Transmit or Receive Mode) ²	2		ns
t _{DDTE} Transmit Data Delay After Transmit SCLK ²		7	ns
t _{HOTE} Transmit Data Hold After Transmit SCLK ²	2		ns

¹Referenced to sample edge.

²Referenced to drive edge.

Table 24. Serial Ports—Internal Clock

Parameter	Min	Max	Unit
<i>Timing Requirements</i>			
t _{SFSI} FS Setup Before SCLK (Externally Generated FS in Either Transmit or Receive Mode) ¹	6		ns
t _{HFSI} FS Hold After SCLK (Externally Generated FS in Either Transmit or Receive Mode) ¹	1.5		ns
t _{SDRI} Receive Data Setup Before SCLK ¹	6		ns
t _{HDRI} Receive Data Hold After SCLK ¹	1.5		ns
<i>Switching Characteristics</i>			
t _{DFSI} FS Delay After SCLK (Internally Generated FS in Transmit Mode) ²		3	ns
t _{HOFSI} FS Hold After SCLK (Internally Generated FS in Transmit Mode) ²	-1.0		ns
t _{DFSI} FS Delay After SCLK (Internally Generated FS in Receive Mode) ²		3	ns
t _{HOFSI} FS Hold After SCLK (Internally Generated FS in Receive Mode) ²	-1.0		ns
t _{DDTI} Transmit Data Delay After SCLK ²		3	ns
t _{HDTI} Transmit Data Hold After SCLK ²	-1.0		ns
t _{SCLKW} Transmit or Receive SCLK Width	0.5t _{SCLK} - 2	0.5t _{SCLK} + 2	ns

¹Referenced to the sample edge.

²Referenced to drive edge.

ADSP-21266

Table 25. Serial Ports—Enable and Three-State

Parameter		Min	Max	Unit
<i>Switching Characteristics</i>				
t_{DDTEN}	Data Enable from External Transmit SCLK ¹	2		ns
t_{DDTTE}	Data Disable from External Transmit SCLK ¹		7	ns
t_{DDTIN}	Data Enable from Internal Transmit SCLK ¹	-1		ns

¹ Referenced to drive edge.

Table 26. Serial Ports—External Late Frame Sync

Parameter		Min	Max	Unit
<i>Switching Characteristics</i>				
$t_{DDTLFSE}$	Data Delay from Late External Transmit FS or External Receive FS with MCE = 1, MFD = 0 ¹		7	ns
$t_{DDTENFS}$	Data Enable for MCE = 1, MFD = 0 ¹	0.5		ns

¹ The $t_{DDTLFSE}$ and $t_{DDTENFS}$ parameters apply to left-justified sample pair mode as well as DSP serial mode, and MCE = 1, MFD = 0.

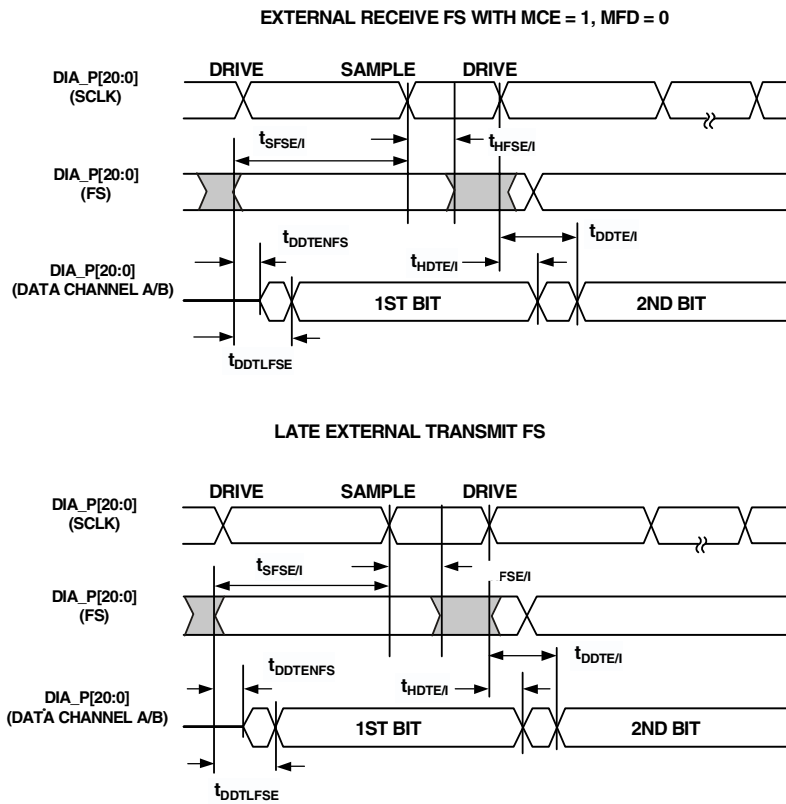

NOTE: SERIAL PORT SIGNALS (SCLK, FS, DATA CHANNEL A/B) ARE ROUTED TO THE DAI_P[20:1] PINS USING THE SRU. THE TIMING SPECIFICATIONS PROVIDED HERE ARE VALID AT THE DAI_P[20:1] PINS.

Figure 21. External Late Frame Sync¹

¹ This figure reflects changes made to support left-justified sample pair mode.

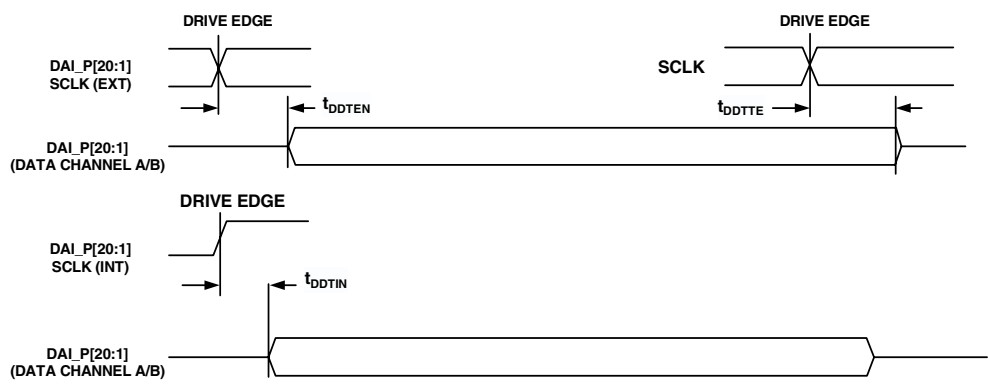
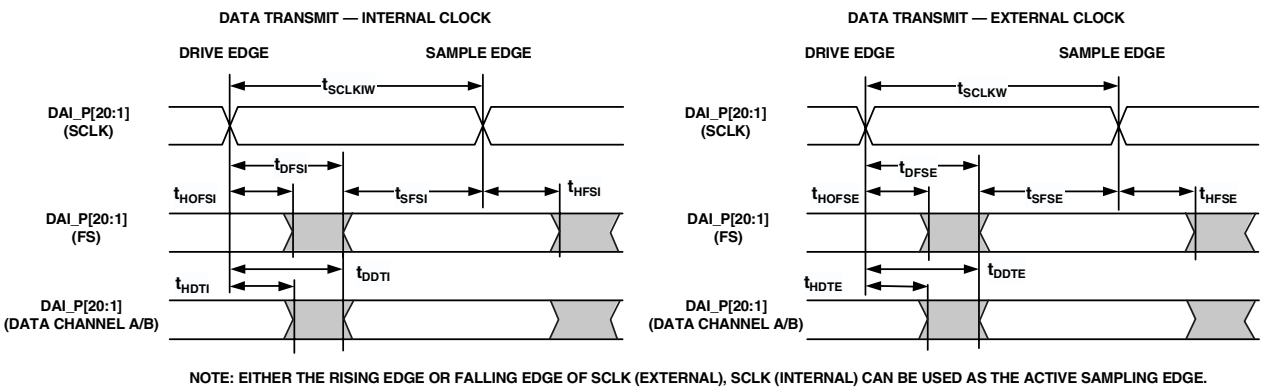
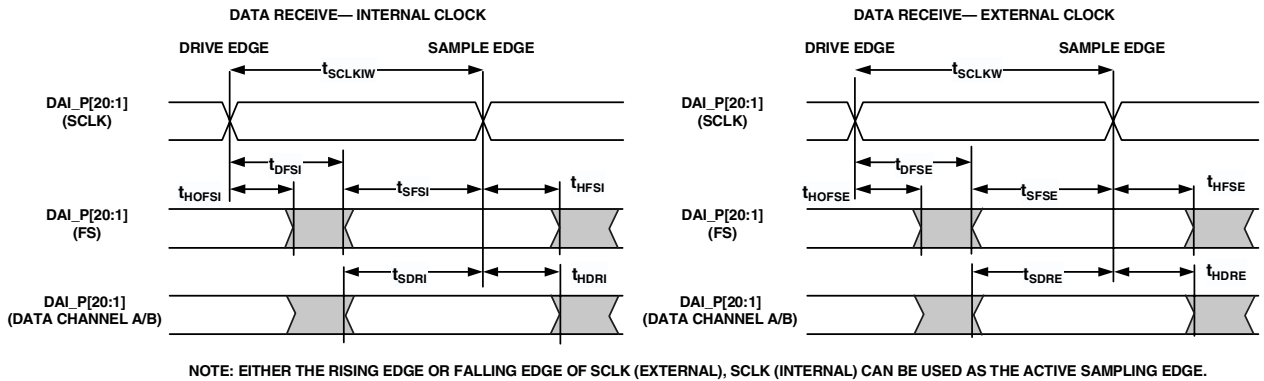

Figure 22. Serial Ports

ADSP-21266

Input Data Port (IDP)

The timing requirements for the IDP are given in [Table 27](#). IDP Signals (SCLK, FS, SDATA) are routed to the DAI_P[20:1] pins using the SRU. Therefore, the timing specifications provided below are valid at the DAI_P[20:1] pins.

Table 27. Input Data Port

Parameter	Min	Max	Unit
<i>Timing Requirements</i>			
t_{SISFS} FS Setup Before SCLK Rising Edge ¹	2.5		ns
t_{SIHFS} FS Hold After SCLK Rising Edge ¹	2.5		ns
t_{SISD} SData Setup Before SCLK Rising Edge ¹	2.5		ns
t_{SIHD} SData Hold After SCLK Rising Edge ¹	2.5		ns
$t_{IDPCLKW}$ Clock Width	7		ns
t_{IDPCLK} Clock Period	20		ns

¹ DATA, SCLK, FS can come from any of the DAI pins. SCLK and FS can also come via the Precision Clock Generators (PCG) or SPORTs. PCG's input can be either CLKIN or any of the DAI pins.

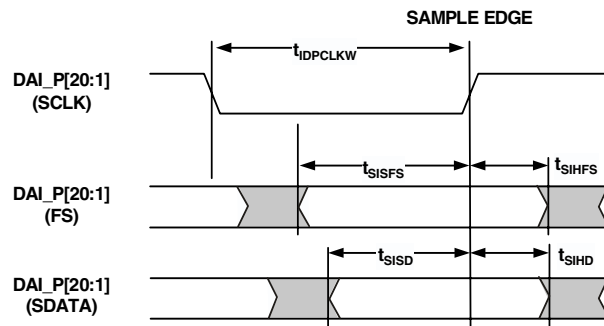

Figure 23. IDP Master Timing

Parallel Data Acquisition Port (PDAP)

The timing requirements for the PDAP are provided in [Table 28](#). PDAP is the parallel mode operation of Channel 0 of the IDP. For details on the operation of the IDP, see the IDP chapter of the *ADSP-2126x Peripherals Manual*. Note that the

most significant 16 bits of external PDAP data can be provided through either the parallel port AD[15:0] or the DAI_P[20:5] pins. The remaining 4 bits can only be sourced through DAI_P[4:1]. The timing below is valid at the DAI_P[20:1] pins or at the AD[15:0] pins.

Table 28. Parallel Data Acquisition Port (PDAP)

Parameter		Min	Max	Unit
<i>Timing Requirements</i>				
$t_{SPCLKEN}$	PDAP_CLKEN Setup Before PDAP_CLK Sample Edge ¹	2.5		ns
$t_{HPCLKEN}$	PDAP_CLKEN Hold After PDAP_CLK Sample Edge ¹	2.5		ns
t_{PDSD}	PDAP_DAT Setup Before SCLK PDAP_CLK Sample Edge ¹	2.5		ns
t_{PDHD}	PDAP_DAT Hold After SCLK PDAP_CLK Sample Edge ¹	2.5		ns
t_{PDCLKW}	Clock Width	7		ns
t_{PDCLK}	Clock Period	20		ns
<i>Switching Characteristics</i>				
t_{PDHLDD}	Delay of PDAP Strobe After Last PDAP_CLK Capture Edge for a Word	$2 \times t_{CCLK}$		ns
t_{PDSTRB}	PDAP Strobe Pulse Width	$1 \times t_{CCLK} - 1$		ns

¹ Source pins of DATA are ADDR[7:0], DATA[7:0], or DAI pins. Source pins for SCLK and FS are: 1) DAI pins, 2) CLKIN through PCG, or 3) DAI pins through PCG.

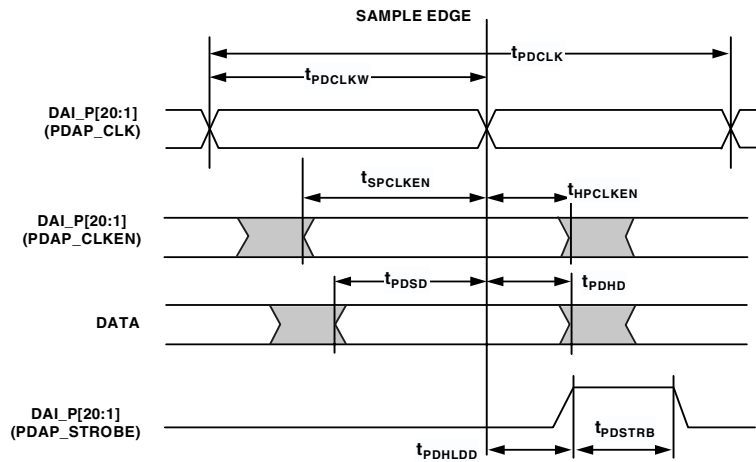

Figure 24. PDAP Timing

ADSP-21266

SPI Interface—Master

Table 29. SPI Interface Protocol—Master Switching and Timing Specifications

Parameter		Min	Max	Unit
<i>Switching Characteristics</i>				
$t_{SPICLKM}$	Serial Clock Cycle	$8 \times t_{CCLK}$		ns
t_{SPICHM}	Serial Clock High Period	$4 \times t_{CCLK} - 2$		ns
t_{SPICLM}	Serial Clock Low Period	$4 \times t_{CCLK} - 2$		ns
$t_{DDSPIDM}$	SPICLK Edge to Data Out Valid (Data Out Delay Time)		3	ns
$t_{HDSPIDM}$	SPICLK Edge to Data Out Not Valid (Data Out Hold Time)	10		ns
t_{SDSCIM}	FLAG3-0 OUT (SPI Device Select) Low to First SPICLK Edge	$4 \times t_{CCLK} - 2$		ns
t_{HDSM}	Last SPICLK Edge to FLAG3-0 OUT High	$4 \times t_{CCLK} - 1$		ns
t_{SPITDM}	Sequential Transfer Delay	$4 \times t_{CCLK} - 1$		ns
<i>Timing Requirements</i>				
t_{SSPIDM}	Data Input Valid to SPICLK Edge (Data Input Set-Up Time)	5		ns
t_{HSPIDM}	SPICLK Last Sampling Edge to Data Input Not Valid	2		ns

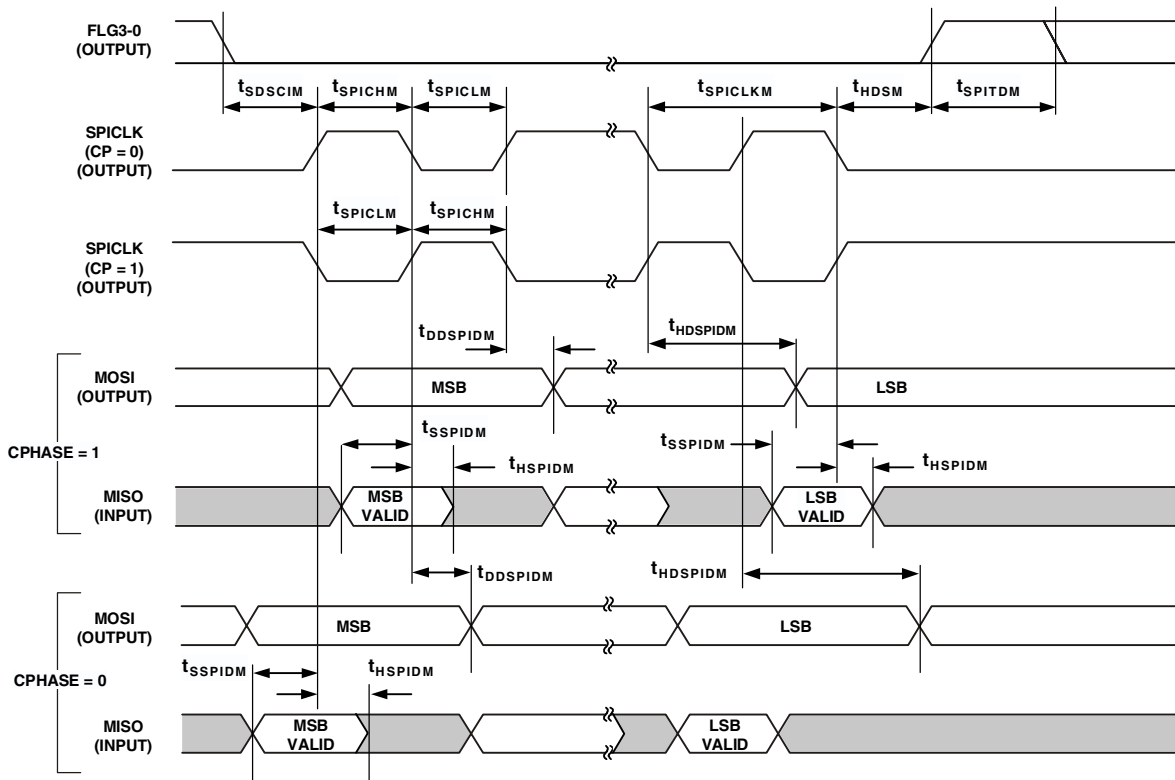

Figure 25. SPI Master Timing

SPI Interface—Slave

Table 30. SPI Interface Protocol—Slave Switching and Timing Specifications

Parameter		Min	Max	Unit
<i>Switching Characteristics</i>				
t_{DSOE}	\overline{SPIDS} Assertion to Data Out Active	0	5	ns
t_{DSDHI}	\overline{SPIDS} Deassertion to Data High Impedance	0	5	ns
$t_{DDSPIDS}$	SPICLK Edge to Data Out Valid (Data Out Delay Time)		7.5	ns
$t_{HDSPIDS}$	SPICLK Edge to Data Out Not Valid (Data Out Hold Time)	$2 \times t_{CCLK} - 2$		ns
t_{DSOV}	\overline{SPIDS} Assertion to Data Out Valid (CPHASE = 0)		$5 \times t_{CCLK} + 2$	ns
<i>Timing Requirements</i>				
$t_{SPICLKS}$	Serial Clock Cycle	$4 \times t_{CCLK}$		ns
$t_{SPICHHS}$	Serial Clock High Period	$2 \times t_{CCLK} - 2$		ns
$t_{SPICLHS}$	Serial Clock Low Period	$2 \times t_{CCLK} - 2$		ns
t_{SDSCO}	\overline{SPIDS} Assertion to First SPICLK Edge CPHASE = 0	$2 \times t_{CCLK} + 1$		ns
	CPHASE = 1	$2 \times t_{CCLK} + 1$		ns
t_{HDS}	Last SPICLK Edge to \overline{SPIDS} Not Asserted CPHASE = 0	$2 \times t_{CCLK}$		ns
t_{SSPIDS}	Data Input Valid to SPICLK Edge (Data Input Set-up Time)	2		ns
t_{HSPIDS}	SPICLK Last Sampling Edge to Data Input Not Valid	2		ns
t_{SDPPW}	\overline{SPIDS} Deassertion Pulse Width (CPHASE = 0)	$2 \times t_{CCLK}$		ns

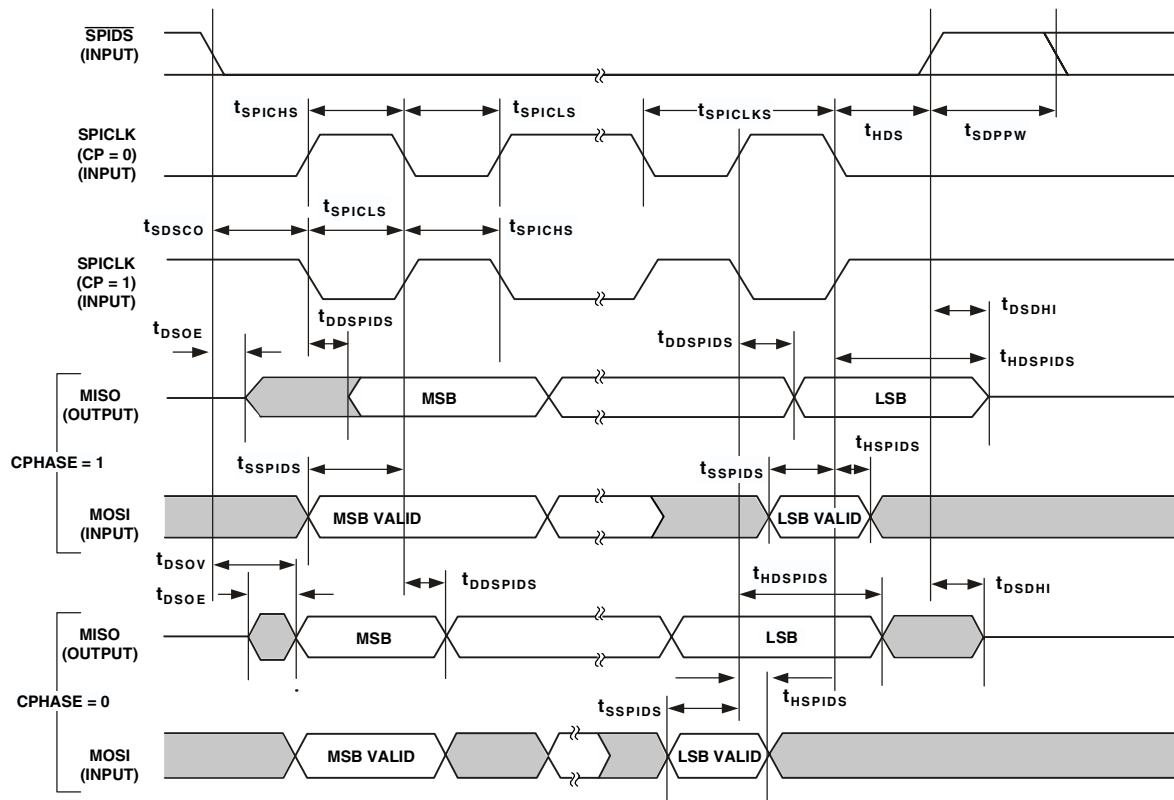

Figure 26. SPI Slave Timing

ADSP-21266

JTAG Test Access Port and Emulation

Table 31. JTAG Test Access Port and Emulation

Parameter	Min	Max	Unit
<i>Timing Requirements</i>			
t_{TCK} TCK Period	20		ns
t_{STAP} TDI, TMS Setup Before TCK High	5		ns
t_{HTAP} TDI, TMS Hold After TCK High	6		ns
t_{SSYS} System Inputs Setup Before TCK Low ¹	7		ns
t_{HSYS} System Inputs Hold After TCK Low ¹	8		ns
t_{TRSTW} \overline{TRST} Pulse Width	$4t_{CK}$		ns
<i>Switching Characteristics</i>			
t_{DTDO} TDO Delay from TCK Low		7	ns
t_{DSYS} System Outputs Delay After TCK Low ²		10	ns

¹ System Inputs = AD15-0, \overline{SPIDS} , CLKCFG1-0, \overline{RESET} , BOOTCFG1-0, MISO, MOSI, SPICLK, DAI_Px, FLAG3-0.

² System Outputs = MISO, MOSI, SPICLK, DAI_Px, AD15-0, \overline{RD} , \overline{WR} , FLAG3-0, CLKOUT, EMU, ALE.

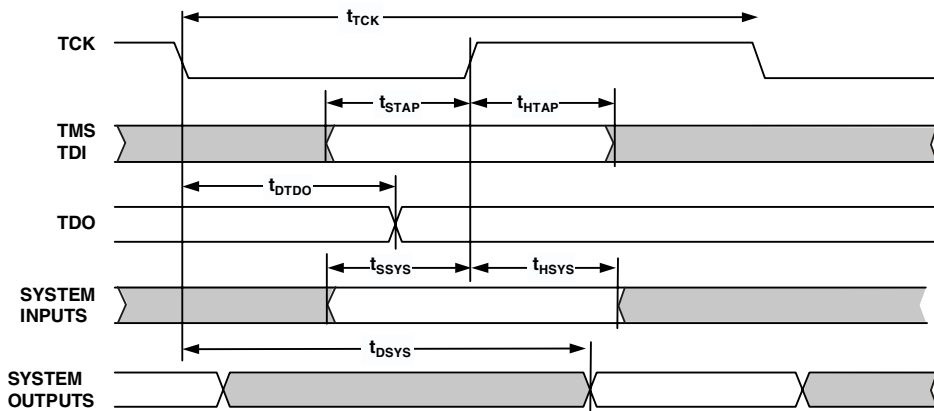

Figure 27. IEEE 11499.1 JTAG Test Access Port

OUTPUT DRIVE CURRENTS

Figure 28 shows typical I-V characteristics for the output drivers of the ADSP-21266. The curves represent the current drive capability of the output drivers as a function of output voltage.

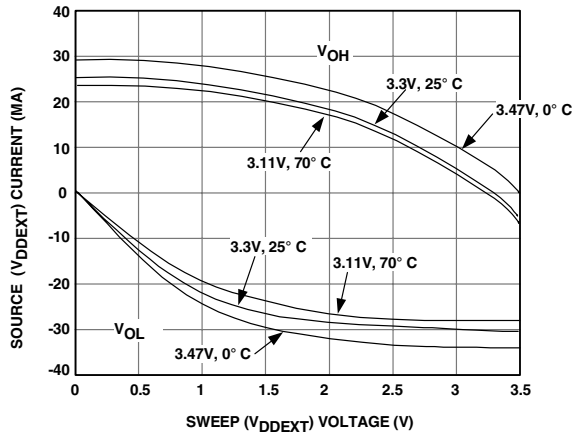

Figure 28. ADSP-21266 Typical Drive

TEST CONDITIONS

The ac signal specifications (timing parameters) appear in Table 10 on Page 19 through Table 31 on Page 36. These include output disable time, output enable time, and capacitive loading.

Timing is measured on signals when they cross the 1.5 V level as described in Figure 30. All delays (in nanoseconds) are measured between the point that the first signal reaches 1.5 V and the point that the second signal reaches 1.5 V.

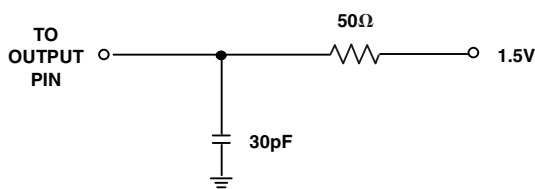

Figure 29. Equivalent Device Loading for AC Measurements (Includes All Fixtures)



Figure 30. Voltage Reference Levels for AC Measurements

CAPACITIVE LOADING

Output delays and holds are based on standard capacitive loads: 30 pF on all pins (see Figure 29). Figure 32 shows graphically how output delays and holds vary with load capacitance (Note that this graph or derating does not apply to output disable delays). The graphs of Figure 31, Figure 32, and Figure 33 may not be linear outside the ranges shown for Typical Output Delay vs. Load Capacitance and Typical Output Rise Time (20%-80%, V=Min) vs. Load Capacitance.

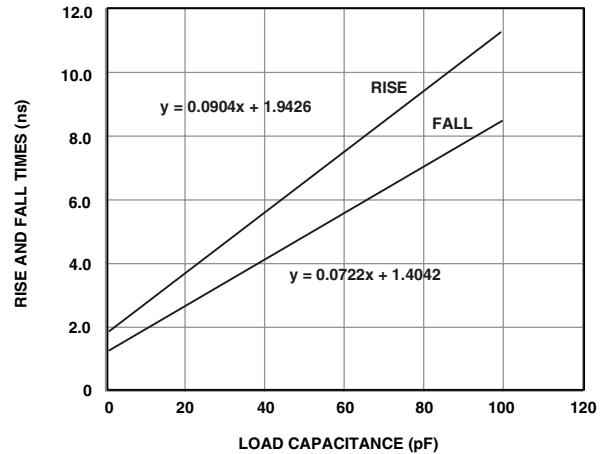

Figure 31. Typical Output Rise Time (20%-80%, $V_{DDEXT} = Max$)

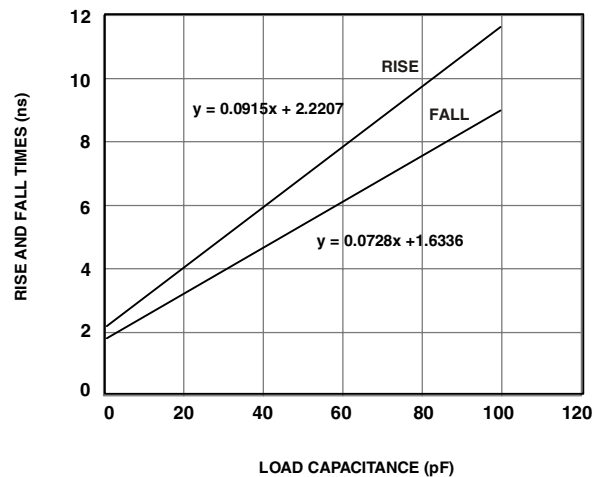

Figure 32. Typical Output Rise/Fall Time (20%-80%, $V_{DDEXT} = Min$)

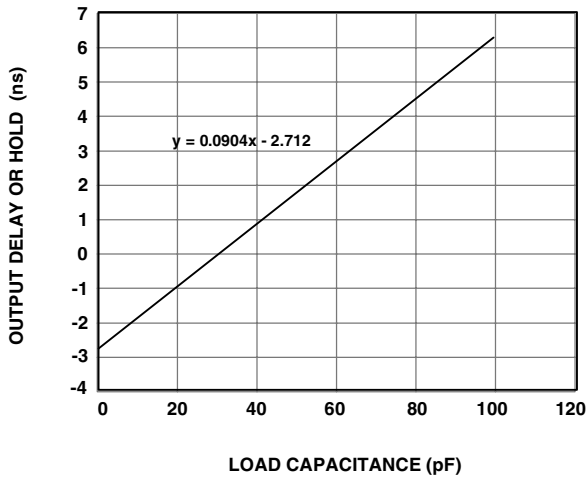

Figure 33. Typical Output Delay or Hold vs. Load Capacitance (at Ambient Temperature)

ENVIRONMENTAL CONDITIONS

The ADSP-21266 processor is rated for performance over the commercial temperature range, $T_{AMB} = 0^{\circ}\text{C}$ to 70°C .

THERMAL CHARACTERISTICS

Table 32 and Table 33 airflow measurements comply with JEDEC standards JESD51-2 and JESD51-6 and the junction-to-board measurement complies with JESD51-8. The junction-to-case measurement complies with MIL-STD-883. All measurements use a 2S2P JEDEC test board.

To determine the Junction Temperature of the device while on the application PCB, use:

$$T_J = T_{CASE} + (\Psi_{JT} \times P_D)$$

where:

T_J = Junction temperature $^{\circ}\text{C}$

T_{CASE} = Case temperature ($^{\circ}\text{C}$) measured at the top center of the package

Ψ_{JT} = Junction-to-Top (of package) characterization parameter is the Typical value from Table 32 and Table 33.

P_D = Power dissipation (see EE Note #216)

Values of θ_{JA} are provided for package comparison and PCB design considerations. θ_{JA} can be used for a first order approximation of T_J by the equation

$$T_J = T_A + (\theta_{JA} \times P_D)$$

where:

T_A = Ambient Temperature $^{\circ}\text{C}$

Values of θ_{JC} are provided for package comparison and PCB design considerations when an external heat sink is required.

Values of θ_{JB} are provided for package comparison and PCB design considerations.

Table 32. Thermal Characteristics for 136-Ball BGA

Parameter	Condition	Typical	Unit
θ_{JA}	Airflow = 0 m/s	28.2	$^{\circ}\text{C}/\text{W}$
θ_{JMA}	Airflow = 1 m/s	24.4	$^{\circ}\text{C}/\text{W}$
θ_{JMA}	Airflow = 2 m/s	23.3	$^{\circ}\text{C}/\text{W}$
θ_{JB}		20.1	$^{\circ}\text{C}/\text{W}$
θ_{JC}		7.0	$^{\circ}\text{C}/\text{W}$
Ψ_{JT}	Airflow = 0 m/s	0.1	$^{\circ}\text{C}/\text{W}$
Ψ_{JMT}	Airflow = 1 m/s	0.3	$^{\circ}\text{C}/\text{W}$
Ψ_{JMT}	Airflow = 2 m/s	0.4	$^{\circ}\text{C}/\text{W}$

Table 33. Thermal Characteristics for 144-Lead LQFP

Parameter	Condition	Typical	Unit
θ_{JA}	Airflow = 0 m/s	32.5	$^{\circ}\text{C}/\text{W}$
θ_{JMA}	Airflow = 1 m/s	28.9	$^{\circ}\text{C}/\text{W}$
θ_{JMA}	Airflow = 2 m/s	27.8	$^{\circ}\text{C}/\text{W}$
θ_{JC}		7.8	$^{\circ}\text{C}/\text{W}$
Ψ_{JT}	Airflow = 0 m/s	0.5	$^{\circ}\text{C}/\text{W}$
Ψ_{JMT}	Airflow = 1 m/s	0.8	$^{\circ}\text{C}/\text{W}$
Ψ_{JMT}	Airflow = 2 m/s	1.0	$^{\circ}\text{C}/\text{W}$

136-BALL BGA PIN CONFIGURATIONS

The following table shows the ADSP-21266's pin names and their default function after reset (in parentheses). [Figure 34 on Page 41](#) shows the BGA package pin assignments.

Table 34. 136-Ball BGA Pin Assignments

Pin Name	BGA Pin No.	Pin Name	BGA Pin No.	Pin Name	BGA Pin No.	Pin Name	BGA Pin No.
CLKCFG0	A01	CLKCFG1	B01	BOOTCFG1	C01	V _{DDINT}	D01
XTAL	A02	GND	B02	BOOTCFG0	C02	GND	D02
TMS	A03	V _{DDEXT}	B03	GND	C03	GND	D04
TCK	A04	CLKIN	B04	GND	C12	GND	D05
TDI	A05	TRST	B05	GND	C13	GND	D06
CLKOUT	A06	A _{VSS}	B06	V _{DDINT}	C14	GND	D09
TDO	A07	A _{VDD}	B07			GND	D10
EMU	A08	V _{DDEXT}	B08			GND	D11
MOSI	A09	SPICLK	B09			GND	D13
MISO	A10	RESET	B10			V _{DDINT}	D14
SPIDS	A11	V _{DDINT}	B11				
V _{DDINT}	A12	GND	B12				
GND	A13	GND	B13				
GND	A14	GND	B14				
V _{DDINT}	E01	FLAG1	F01	AD7	G01	AD6	H01
GND	E02	FLAG0	F02	V _{DDINT}	G02	V _{DDEXT}	H02
GND	E04	GND	F04	V _{DDEXT}	G13	DAI_P18 (SD5B)	H13
GND	E05	GND	F05	DAI_P19 (SCLK45)	G14	DAI_P17 (SD5A)	H14
GND	E06	GND	F06				
GND	E09	GND	F09				
GND	E10	GND	F10				
GND	E11	GND	F11				
GND	E13	FLAG2	F13				
FLAG3	E14	DAI_P20 (SFS45)	F14				

ADSP-21266

Table 34. 136-Ball BGA Pin Assignments (Continued)

Pin Name	BGA Pin No.	Pin Name	BGA Pin No.	Pin Name	BGA Pin No.	Pin Name	BGA Pin No.
AD5	J01	AD3	K01	AD2	L01	AD0	M01
AD4	J02	V _{DDINT}	K02	AD1	L02	$\overline{\text{WR}}$	M02
GND	J04	GND	K04	GND	L04	GND	M03
GND	J05	GND	K05	GND	L05	GND	M12
GND	J06	GND	K06	GND	L06	DAI_P12 (SD3B)	M13
GND	J09	GND	K09	GND	L09	DAI_P13 (SCLK23)	M14
GND	J10	GND	K10	GND	L10		
GND	J11	GND	K11	GND	L11		
V _{DDINT}	J13	GND	K13	GND	L13		
DAI_P16 (SD4B)	J14	DAI_P15 (SD4A)	K14	DAI_P14 (SFS23)	L14		
AD15	N01	AD14	P01				
ALE	N02	AD13	P02				
$\overline{\text{RD}}$	N03	AD12	P03				
V _{DDINT}	N04	AD11	P04				
V _{DDEXT}	N05	AD10	P05				
AD8	N06	AD9	P06				
V _{DDINT}	N07	DAI_P1 (SD0A)	P07				
DAI_P2 (SD0B)	N08	DAI_P3 (SCLK0)	P08				
V _{DDEXT}	N09	DAI_P5 (SD1A)	P09				
DAI_P4 (SFS0)	N10	DAI_P6 (SD1B)	P10				
V _{DDINT}	N11	DAI_P7 (SCLK1)	P11				
V _{DDINT}	N12	DAI_P8 (SFS1)	P12				
GND	N13	DAI_P9 (SD2A)	P13				
DAI_P10 (SD2B)	N14	DAI_P11 (SD3A)	P14				

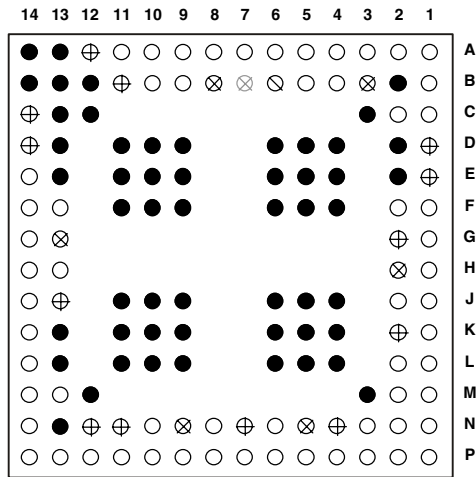

KEY

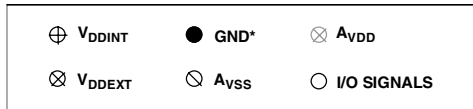

***USE THE CENTER BLOCK OF GROUND PINS TO PROVIDE THERMAL PATHWAYS TO YOUR PRINTED CIRCUIT BOARD'S GROUND PLANE.**

Figure 34. 136-Ball BGA Pin Assignments (Bottom View, Summary)

ADSP-21266

144-LEAD LQFP PIN CONFIGURATIONS

The following table shows the ADSP-21266's pin names and their default function after reset (in parentheses).

Table 35. 144-Lead LQFP Pin Assignments

Pin Name	LQFP Pin No.	Pin Name	LQFP Pin No.	Pin Name	LQFP Pin No.	Pin Name	LQFP Pin No.
V _{DDINT}	1	V _{DDINT}	37	V _{DDEXT}	73	GND	109
CLKCFG0	2	GND	38	GND	74	V _{DDINT}	110
CLKCFG1	3	$\overline{\text{RD}}$	39	V _{DDINT}	75	GND	111
BOOTCFG0	4	ALE	40	GND	76	V _{DDINT}	112
BOOTCFG1	5	AD15	41	DAI_P10 (SD2B)	77	GND	113
GND	6	AD14	42	DAI_P11 (SD3A)	78	V _{DDINT}	114
V _{DDEXT}	7	AD13	43	DAI_P12 (SD3B)	79	GND	115
GND	8	GND	44	DAI_P13 (SCLK23)	80	V _{DDEXT}	116
V _{DDINT}	9	V _{DDEXT}	45	DAI_P14 (SFS23)	81	GND	117
GND	10	AD12	46	DAI_P15 (SD4A)	82	V _{DDINT}	118
V _{DDINT}	11	V _{DDINT}	47	V _{DDINT}	83	GND	119
GND	12	GND	48	GND	84	V _{DDINT}	120
V _{DDINT}	13	AD11	49	GND	85	$\overline{\text{RESET}}$	121
GND	14	AD10	50	DAI_P16 (SD4B)	86	$\overline{\text{SPIDS}}$	122
FLAG0	15	AD9	51	DAI_P17 (SD5A)	87	GND	123
FLAG1	16	AD8	52	DAI_P18 (SD5B)	88	V _{DDINT}	124
AD7	17	DAI_P1 (SD0A)	53	DAI_P19 (SCLK45)	89	SPICKL	125
GND	18	V _{DDINT}	54	V _{DDINT}	90	MISO	126
V _{DDINT}	19	GND	55	GND	91	MOSI	127
GND	20	DAI_P2 (SD0B)	56	GND	92	GND	128
V _{DDEXT}	21	DAI_P3 (SCLK0)	57	V _{DDEXT}	93	V _{DDINT}	129
GND	22	GND	58	DAI_P20 (SFS45)	94	V _{DDEXT}	130
V _{DDINT}	23	V _{DDEXT}	59	GND	95	A _{VDD}	131
AD6	24	V _{DDINT}	60	V _{DDINT}	96	A _{VSS}	132
AD5	25	GND	61	FLAG2	97	GND	133
AD4	26	DAI_P4 (SFS0)	62	FLAG3	98	CLKOUT	134
V _{DDINT}	27	DAI_P5 (SD1A)	63	V _{DDINT}	99	EMU	135
GND	28	DAI_P6 (SD1B)	64	GND	100	TDO	136
AD3	29	DAI_P7 (SCLK1)	65	V _{DDINT}	101	TDI	137
AD2	30	V _{DDINT}	66	GND	102	TRST	138
V _{DDEXT}	31	GND	67	V _{DDINT}	103	TCK	139
GND	32	V _{DDINT}	68	GND	104	TMS	140
AD1	33	GND	69	V _{DDINT}	105	GND	141
AD0	34	DAI_P8 (SFS1)	70	GND	106	CLKIN	142
$\overline{\text{WR}}$	35	DAI_P9 (SD2A)	71	V _{DDINT}	107	XTAL	143
V _{DDINT}	36	V _{DDINT}	72	V _{DDINT}	108	V _{DDEXT}	144

PACKAGE DIMENSIONS

The ADSP-21266 is available in a 136-ball BGA package and a 144-lead LQFP package shown in [Figure 35](#) and [Figure 36](#).

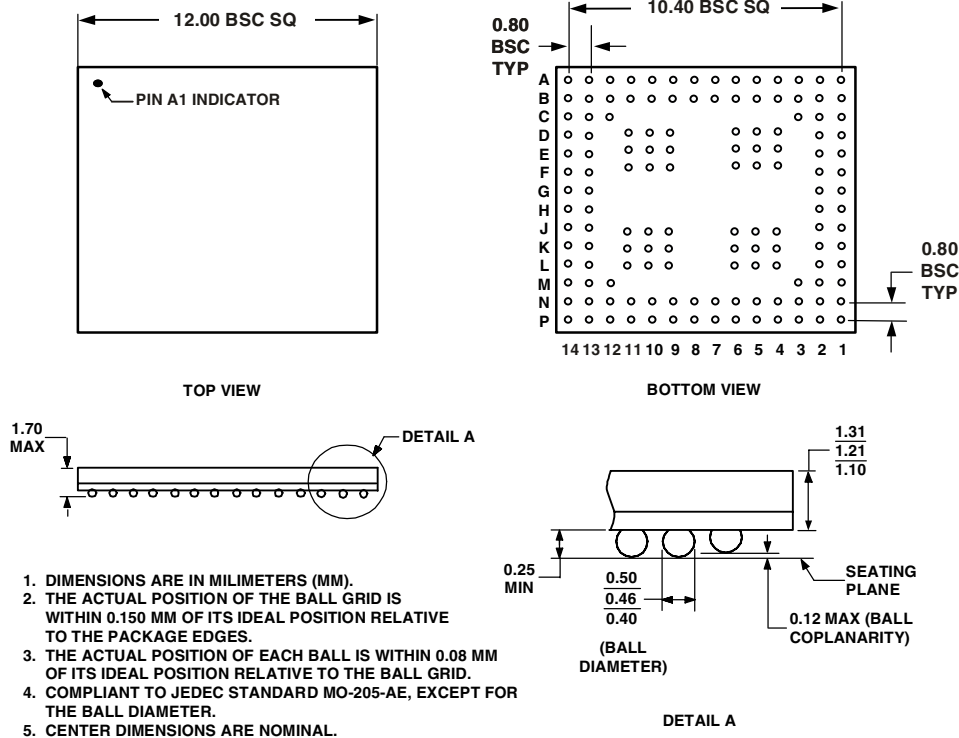
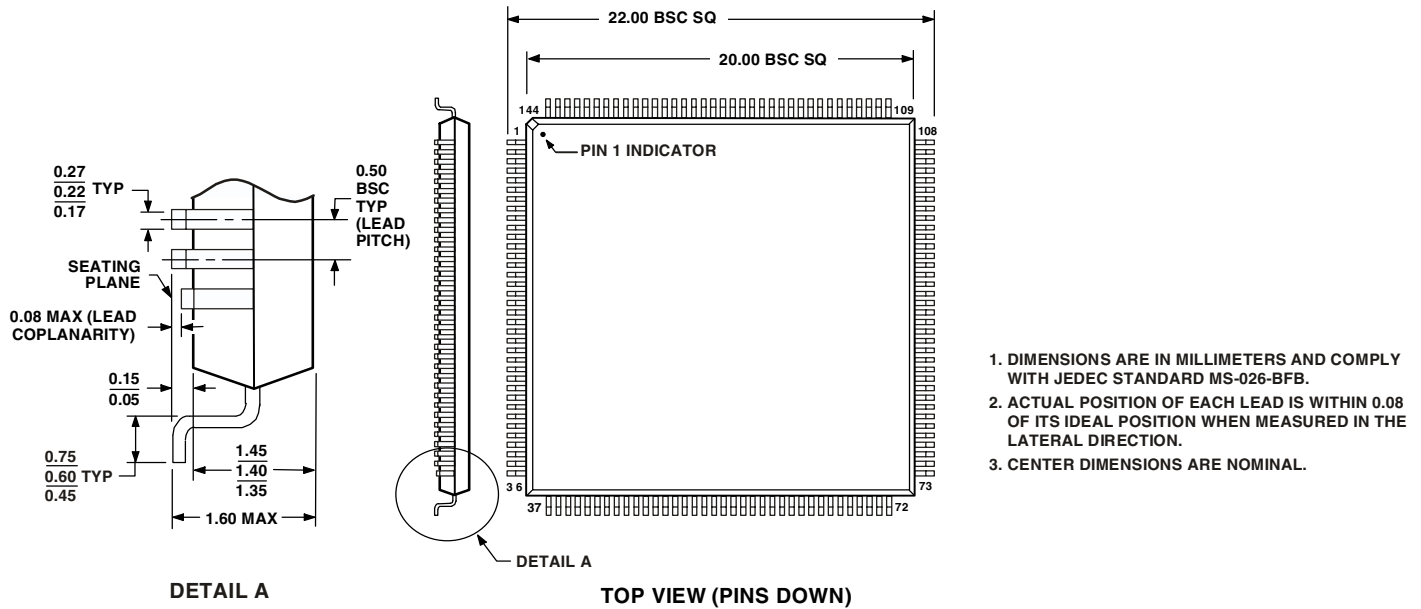

Figure 35. 136-Ball BGA (BC-136)

ADSP-21266



1. DIMENSIONS ARE IN MILLIMETERS AND COMPLY WITH JEDEC STANDARD MS-026-BFB.
2. ACTUAL POSITION OF EACH LEAD IS WITHIN 0.08 OF ITS IDEAL POSITION WHEN MEASURED IN THE LATERAL DIRECTION.
3. CENTER DIMENSIONS ARE NOMINAL.

Figure 36. 144-Lead LQFP (ST-144)

ORDERING GUIDE

Analog Devices offers a wide variety of audio algorithms and combinations to run on the ADSP-21266 DSP. For a complete list, visit our website at www.analog.com/SHARC

Part Number	Ambient Temperature Range	Instruction Rate	On-Chip SRAM	ROM	Operating Voltage	Package ¹
ADSP-21266SKSTZ-1B ²	0°C to +70°C	150 MHz	2 Mbit	4 Mbit	1.2 INT/3.3 EXT V	144-Lead LQFP; Pb-free
ADSP-21266SKSTZ-2B ²	0°C to +70°C	200 MHz	2 Mbit	4 Mbit	1.2 INT/3.3 EXT V	144-Lead LQFP; Pb-free
ADSP-21266SKBCZ-2B ²	0°C to +70°C	200 MHz	2 Mbit	4 Mbit	1.2 INT/3.3 EXT V	136-Lead BGA; Pb-free
ADSP-21266SKBCZ-2C ²	0°C to +70°C	200 MHz	2 Mbit	4 Mbit	1.2 INT/3.3 EXT V	136-Lead BGA; Pb-free

¹ BC indicates Ball Grid Array package. ST indicates Low Profile Quad Flat package.

² Z = Pb-free part. For more information about lead-free package offerings, please visit www.analog.com.

This datasheet has been download from:

www.datasheetcatalog.com

Datasheets for electronics components.