

**SUMMARY**

High performance 32-bit/40-bit floating point processor optimized for professional audio processing

At 333 MHz/2 GFLOPs, with unique audio centric peripherals such as the Digital Audio Interface the ADSP-21363 SHARC processor is ideal for applications that require industry leading equalization, reverberation and other effects processing

Single-Instruction Multiple-Data (SIMD) computational architecture

Two 32-bit IEEE floating-point/32-bit fixed-point/40-bit extended precision floating-point computational units, each with a multiplier, ALU, shifter, and register file

On-chip memory—3M bit of on-chip SRAM and a dedicated 4M bit of on-chip mask-programmable ROM

Code compatible with all other members of the SHARC family

The ADSP-21363 is available with a 333 MHz core instruction rate. For complete ordering information, see [Ordering Guide on Page 44](#)

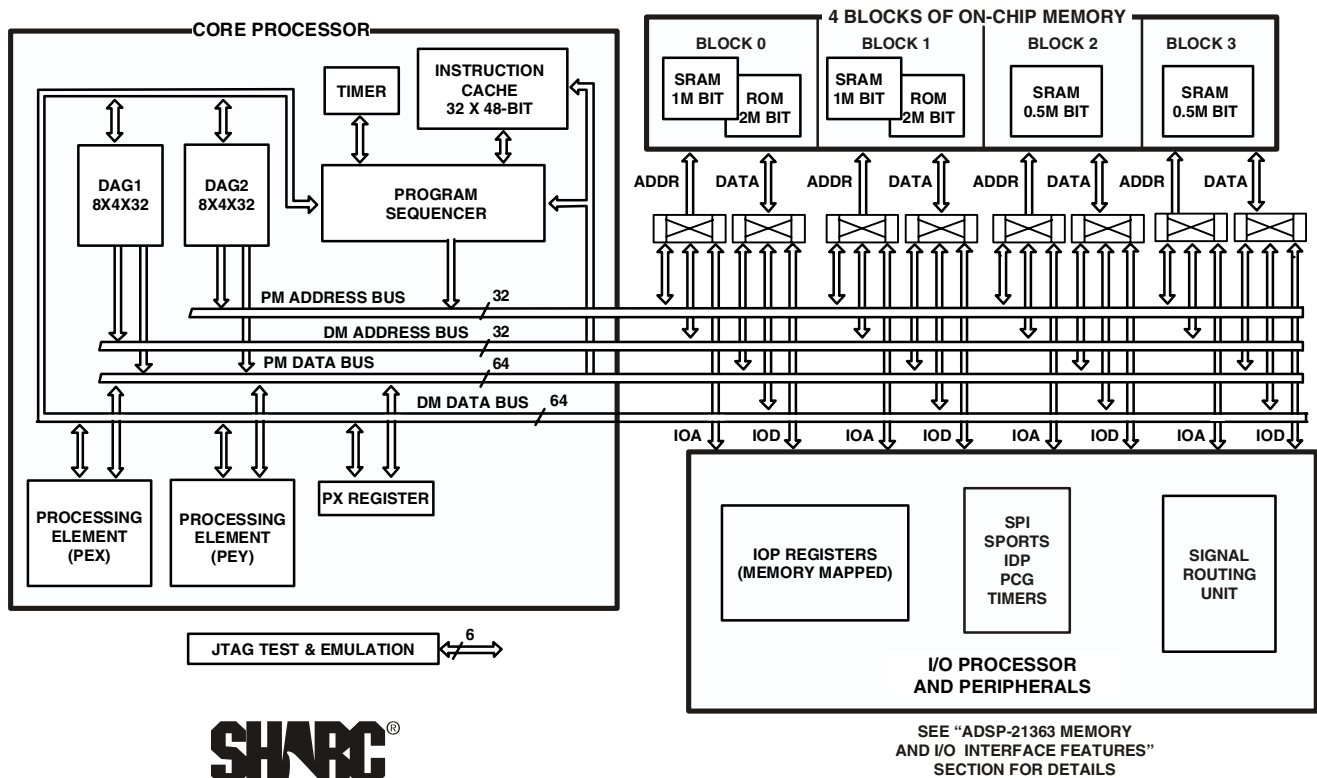

Figure 1. Functional Block Diagram – Processor Core

SHARC and the SHARC logo are registered trademarks of Analog Devices, Inc.

**Rev. PrA**

Information furnished by Analog Devices is believed to be accurate and reliable. However, no responsibility is assumed by Analog Devices for its use, nor for any infringements of patents or other rights of third parties that may result from its use. Specifications subject to change without notice. No license is granted by implication or otherwise under any patent or patent rights of Analog Devices. Trademarks and registered trademarks are the property of their respective companies.

**KEY FEATURES – PROCESSOR CORE**

At 333 MHz (3.0 ns) core instruction rate, the ADSP-21363 performs 2 GFLOPS/666 MMACS

3M bit on-chip single-ported SRAM (1M Bit in blocks 0 and 1, and 0.50M Bit in blocks 2 and 3) for simultaneous access by the core processor and DMA

4M bit on-chip mask-programmable ROM (2M bit in block 0 and 2M bit in block 1)

Dual Data Address Generators (DAGs) with modulo and bit-reverse addressing

Zero-overhead looping with single-cycle loop setup, providing efficient program sequencing

Single Instruction Multiple Data (SIMD) architecture provides:

- Two computational processing elements
- Concurrent execution
- Code compatibility with other SHARC family members at the assembly level
- Parallelism in busses and computational units allows single cycle executions (with or without SIMD) of a multiply operation, an ALU operation, a dual memory read or write, and an instruction fetch

Transfers between memory and core at a sustained 5.4G bytes/s bandwidth at 333 MHz core instruction rate

**INPUT/OUTPUT FEATURES**

DMA Controller supports:

- 25 DMA channels for transfers between ADSP-21363 internal memory and a variety of peripherals
- 32-bit DMA transfers at core clock speed, in parallel with full-speed processor execution
- Asynchronous parallel port provides access to asynchronous external memory
- 16 multiplexed address/data lines support 24-bit address external address range with 8-bit data or 16-bit address external address range with 16-bit data
- 55M byte per sec transfer rate

External memory access in a dedicated DMA channel

- 8- to 32- bit and 16- to 32-bit packing options
- Programmable data cycle duration options: 2 to 31 CCLK

Digital audio interface (DAI) includes six serial ports, two Precision Clock Generators, an Input Data Port, three timers, and a Signal routing unit

Six dual data line serial ports that operate at up to 50M bit/s on each data line—each has a clock, frame sync and two data lines that can be configured as either a receiver or transmitter pair

Left-justified Sample Pair and I<sup>2</sup>S Support, programmable direction for up to 24 simultaneous receive or transmit channels using two I<sup>2</sup>S compatible stereo devices per serial port

TDM support for telecommunications interfaces including 128 TDM channel support for newer telephony interfaces such as H.100/H.110

Up to 12 TDM stream support, each with 128 channels per frame

Companding selection on a per channel basis in TDM mode

Input data port provides an additional input path to the SHARC core, configurable as eight channels of serial data or seven channels of serial data and a single channel of up to 20-bit wide parallel data

Signal routing unit provides configurable and flexible connections between all DAI components—six serial ports, two precision clock generators, an input data port with a data acquisition port, one SPI port, three timers, 10 interrupts, six flag inputs, six flag outputs, and 20 SRU I/O pins (DAI\_P20-1)

Two Serial Peripheral Interfaces (SPI): primary on dedicated pins, secondary on DAI pins provide:

- Master or slave serial boot through primary SPI
- Full-duplex operation
- Master-Slave mode multi-master support
- Open drain outputs
- Programmable baud rates, clock polarities and phases

3 Muxed Flag/IRQ lines

1 Muxed Flag/Timer expired line

Pulse Width Modulation provides:

- 16 PWM outputs configured as four groups of four outputs
- Supports center-aligned or edge-aligned PWM waveforms
- Can generate complementary signals on two outputs in paired mode or independent signals in non paired mode

PLL has a wide variety of software and hardware multiplier/divider ratios

Dual voltage: 3.3 V I/O, 1.2 V core

Available in 136-ball Mini-BGA and 144-lead INT-HS LQFP Packages (see [Ordering Guide on Page 44](#))

## GENERAL DESCRIPTION

The ADSP-21363 SHARC processor is a member of the SIMD SHARC family of DSPs that feature Analog Devices' Super Harvard Architecture. The ADSP-21363 is source code compatible with the ADSP-2126x, and ADSP-2116x DSPs as well as with first generation ADSP-2106x SHARC processors in SISD (Single-Instruction, Single-Data) mode. The ADSP-21363 is a 32-bit/40-bit floating point processor optimized for professional audio applications with a large on-chip SRAM, multiple internal buses to eliminate I/O bottlenecks, and an innovative Digital Audio Interface (DAI).

As shown in the functional block diagram on Page 1, the ADSP-21363 uses two computational units to deliver a significant performance increase over previous SHARC processors on a range of signal processing algorithms. Fabricated in a state-of-the-art, high speed, CMOS process, the ADSP-21363 processor achieves an instruction cycle time of 3.0 ns at 333 MHz. With its SIMD computational hardware, the ADSP-21363 can perform 2 GFLOPS running at 333 MHz.

Table 1 shows performance benchmarks for the ADSP-21363.

**Table 1. ADSP-21363 Benchmarks (at 333 MHz)**

Benchmark Algorithm	Speed (at 333 MHz)
1024 Point Complex FFT (Radix 4, with reversal)	27.9 $\mu$ s
FIR Filter (per tap) <sup>1</sup>	1.5 ns
IIR Filter (per biquad) <sup>1</sup>	6.0 ns
Matrix Multiply (pipelined)	
[3x3] $\times$ [3x1]	13.5 ns
[4x4] $\times$ [4x1]	23.9 ns
Divide (y/ $\times$ )	10.5 ns
Inverse Square Root	16.3 ns

<sup>1</sup>Assumes two files in multichannel SIMD mode

The ADSP-21363 continues SHARC's industry leading standards of integration for DSPs, combining a high performance 32-bit DSP core with integrated, on-chip system features.

The block diagram of the ADSP-21363 on Page 1, illustrates the following architectural features:

- Two processing elements, each of which comprises an ALU, Multiplier, Shifter and Data Register File
- Data Address Generators (DAG1, DAG2)
- Program sequencer with instruction cache
- PM and DM buses capable of supporting four 32-bit data transfers between memory and the core at every core processor cycle
- Three Programmable Interval Timers with PWM Generation, PWM Capture/Pulse width Measurement, and External Event Counter Capabilities
- On-Chip SRAM (3M bit)
- On-Chip mask-programmable ROM (4M bit)

- 8- or 16-bit Parallel port that supports interfaces to off-chip memory peripherals
- JTAG test access port

The block diagram of the ADSP-21363 on Page 6, illustrates the following architectural features:

- DMA controller
- Six full duplex serial ports
- Two SPI-compatible interface ports—primary on dedicated pins, secondary on DAI pins
- Digital Audio Interface that includes two precision clock generators (PCG), an input data port (IDP), six serial ports, eight serial interfaces, a 20-bit parallel input port, 10 interrupts, six flag outputs, six flag inputs, three timers, and a flexible signal routing unit (SRU) and an SPI port

Figure 2 on Page 4 shows one sample configuration of a SPORT using the precision clock generators to interface with an I<sup>2</sup>S ADC and an I<sup>2</sup>S DAC with a much lower jitter clock than the serial port would generate itself. Many other SRU configurations are possible.

## ADSP-21363 FAMILY CORE ARCHITECTURE

The ADSP-21363 is code compatible at the assembly level with the ADSP-2126x, ADSP-21160 and ADSP-21161, and with the first generation ADSP-2106x SHARC processors. The ADSP-21363 shares architectural features with the ADSP-2126x and ADSP-2116x SIMD SHARC processors, as detailed in the following sections.

### SIMD Computational Engine

The ADSP-21363 contains two computational processing elements that operate as a Single-Instruction Multiple-Data (SIMD) engine. The processing elements are referred to as PEX and PEY and each contains an ALU, multiplier, shifter and register file. PEX is always active, and PEY may be enabled by setting the PEYEN mode bit in the MODE1 register. When this mode is enabled, the same instruction is executed in both processing elements, but each processing element operates on different data. This architecture is efficient at executing math intensive signal processing algorithms.

Entering SIMD mode also has an effect on the way data is transferred between memory and the processing elements. When in SIMD mode, twice the data bandwidth is required to sustain computational operation in the processing elements. Because of this requirement, entering SIMD mode also doubles the bandwidth between memory and the processing elements. When using the DAGs to transfer data in SIMD mode, two data values are transferred with each access of memory or the register file.

### Independent, Parallel Computation Units

Within each processing element is a set of computational units. The computational units consist of an arithmetic/logic unit (ALU), multiplier, and shifter. These units perform all operations in a single cycle. The three units within each processing

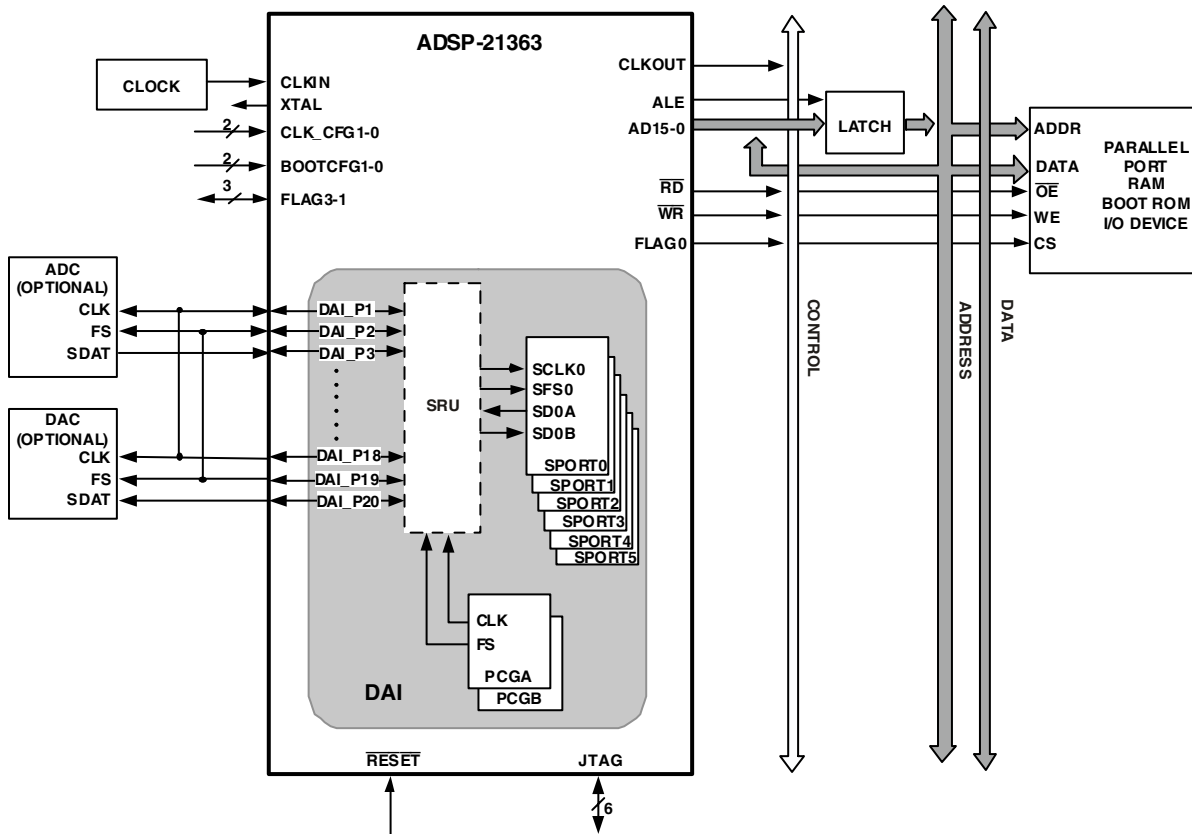

Figure 2. ADSP-21363 System Sample Configuration

element are arranged in parallel, maximizing computational throughput. Single multifunction instructions execute parallel ALU and multiplier operations. In SIMD mode, the parallel ALU and multiplier operations occur in both processing elements. These computation units support IEEE 32-bit single-precision floating-point, 40-bit extended precision floating-point, and 32-bit fixed-point data formats.

**Data Register File**

A general-purpose data register file is contained in each processing element. The register files transfer data between the computation units and the data buses, and store intermediate results. These 10-port, 32-register (16 primary, 16 secondary) register files, combined with the ADSP-2136x enhanced Harvard architecture, allow unconstrained data flow between computation units and internal memory. The registers in PEX are referred to as R0-R15 and in PEY as S0-S15.

**Single-Cycle Fetch of Instruction and Four Operands**

The ADSP-21363 features an enhanced Harvard architecture in which the data memory (DM) bus transfers data and the program memory (PM) bus transfers both instructions and data (see Figure 1 on Page 1). With the ADSP-21363’s separate program and data memory buses and on-chip instruction cache,

the processor can simultaneously fetch four operands (two over each data bus) and one instruction (from the cache), all in a single cycle.

**Instruction Cache**

The ADSP-21363 includes an on-chip instruction cache that enables three-bus operation for fetching an instruction and four data values. The cache is selective—only the instructions whose fetches conflict with PM bus data accesses are cached. This cache allows full-speed execution of core, looped operations such as digital filter multiply-accumulates, and FFT butterfly processing.

**Data Address Generators With Zero-Overhead Hardware Circular Buffer Support**

The ADSP-21363’s two data address generators (DAGs) are used for indirect addressing and implementing circular data buffers in hardware. Circular buffers allow efficient programming of delay lines and other data structures required in digital signal processing, and are commonly used in digital filters and Fourier transforms. The two DAGs of the ADSP-21363 contain sufficient registers to allow the creation of up to 32 circular buffers (16 primary register sets, 16 secondary). The DAGs automatically handle address pointer wraparound, reduce overhead, increase performance, and simplify implementation. Circular buffers can start and end at any memory location.

**Flexible Instruction Set**

The 48-bit instruction word accommodates a variety of parallel operations, for concise programming. For example, the ADSP-21363 can conditionally execute a multiply, an add, and a subtract in both processing elements while branching and fetching up to four 32-bit values from memory—all in a single instruction.

**ADSP-21363 MEMORY AND I/O INTERFACE FEATURES**

The ADSP-21363 adds the following architectural features to the SIMD SHARC family core.

**On-Chip Memory**

The ADSP-21363 contains three megabits of internal SRAM and four megabits of internal mask-programmable ROM. Each block can be configured for different combinations of code and data storage (see Table 2). Each memory block supports single-

cycle, independent accesses by the core processor and I/O processor. The ADSP-21363 memory architecture, in combination with its separate on-chip buses, allow two data transfers from the core and one from the I/O processor, in a single cycle.

The ADSP-21363's SRAM can be configured as a maximum of 96K words of 32-bit data, 192K words of 16-bit data, 64K words of 48-bit instructions (or 40-bit data), or combinations of different word sizes up to three megabits. All of the memory can be accessed as 16-bit, 32-bit, 48-bit, or 64-bit words. A 16-bit floating-point storage format is supported that effectively doubles the amount of data that may be stored on-chip. Conversion between the 32-bit floating-point and 16-bit floating-point formats is performed in a single instruction. While each memory block can store combinations of code and data, accesses are most efficient when one block stores data using the DM bus for transfers, and the other block stores instructions and data using the PM bus for transfers.

Table 2. ADSP-21363 Internal Memory Space

IOP Registers 0x0000 0000 - 0003 FFFF			
Long Word (64 bits)	Extended Precision Normal or Instruction Word (48 bits)	Normal Word (32 bits)	Short Word (16 bits)
BLOCK 0 ROM 0x0004 0000–0x0004 7FFF	BLOCK 0 ROM 0x0008 0000–0x0008 AAAA	BLOCK 0 ROM 0x0008 0000–0x0008 FFFF	BLOCK 0 ROM 0x0010 0000–0x0011 FFFF
Reserved 0x0004 8000–0x0004 BFFF		Reserved 0x0009 0000–0x0009 7FFF	Reserved 0x0012 0000–0x0012 FFFF
BLOCK 0 RAM 0x0004 C000–0x0004 FFFF	BLOCK 0 RAM 0x0009 0000–0x0009 5555	BLOCK 0 RAM 0x0009 8000–0x0009 FFFF	BLOCK 0 RAM 0x0013 0000–0x0013 FFFF
BLOCK 1 ROM 0x0005 0000–0x0005 7FFF	BLOCK 1 ROM 0x000A 0000–0x000A AAAA	BLOCK 1 ROM 0x000A 0000– 0x000A FFFF	BLOCK 1 ROM 0x0014 0000–0x0015 FFFF
Reserved 0x0005 8000–0x0005 BFFF		Reserved 0x000B 0000– 0x000B 7FFF	Reserved 0x0016 0000–0x0016 FFFF
BLOCK 1 RAM 0x0005 C000–0x0005 FFFF	BLOCK 1 RAM 0x000B 0000–0x000B 5555	BLOCK 1 RAM 0x000B 8000–0x000B FFFF	BLOCK 1 RAM 0x0017 0000–0x0017 FFFF
BLOCK 2 RAM 0x0006 0000–0x0006 1FFF	BLOCK 2 RAM 0x000C 0000–0x000C 2AAA	BLOCK 2 RAM 0x000C 0000–0x000C 3FFF	BLOCK 2 RAM 0x0018 0000–0x0018 7FFF
Reserved 0x0006 2000– 0x0006 FFFF		Reserved 0x000C 4000– 0x000D FFFF	Reserved 0x0018 8000–0x001B FFFF
BLOCK 3 RAM 0x0007 0000–0x0007 1FFF	BLOCK 3 RAM 0x000E 0000–0x000E 2AAA	BLOCK 3 RAM 0x000E 0000–0x000E 3FFF	BLOCK 3 RAM 0x001C 0000–0x001C 7FFF
Reserved 0x0007 2000– 0x0007 FFFF		Reserved 0x000E 4000–0x000F FFFF	Reserved 0x001C 8000–0x001F FFFF
			Reserved 0x0020 0000–0xFFFF FFFF

Using the DM bus and PM buses, with one bus dedicated to each memory block, assures single-cycle execution with two data transfers. In this case, the instruction must be available in the cache.

## DMA Controller

The ADSP-21363's on-chip DMA controller allows data transfers without processor intervention. The DMA controller operates independently and invisibly to the processor core, allowing DMA operations to occur while the core is simultaneously executing its program instructions. DMA transfers can occur between the ADSP-21363's internal memory and its serial ports, the SPI-compatible (Serial Peripheral Interface) ports, the IDP (Input Data Port), the Parallel Data Acquisition Port (PDAP), or the parallel port. Twenty-five channels of DMA are available on the ADSP-21363—two for the SPI interface, two for memory-to-memory transfers, twelve via the serial ports, eight via the Input Data Port, and one via the processor's parallel port. Programs can be downloaded to the ADSP-21363 using DMA transfers. Other DMA features include interrupt generation upon completion of DMA transfers, and DMA chaining for automatic linked DMA transfers.

## Digital Audio Interface (DAI)

The Digital Audio Interface (DAI) provides the ability to connect various peripherals to any of the SHARCs DAI pins (DAI\_P20-1).

Programs make these connections using the Signal Routing Unit (SRU, shown in Figure 3).

The SRU is a matrix routing unit (or group of multiplexers) that enables the peripherals provided by the DAI to be interconnected under software control. This allows easy use of the DAI associated peripherals for a much wider variety of applications by using a larger set of algorithms than is possible with nonconfigurable signal paths.

The DAI also includes six serial ports, two precision clock generators (PCGs), an input data port (IDP), an SPI port, six flag outputs and six flag inputs, and three timers. The IDP provides an additional input path to the ADSP-21363 core, configurable as either eight channels of I<sup>2</sup>S serial data or as seven channels plus a single 20-bit wide synchronous parallel data acquisition port. Each data channel has its own DMA channel that is independent from the ADSP-21363's serial ports.

For complete information on using the DAI, see the *ADSP-2136x SHARC Processor Hardware Reference*.

## Serial Ports

The ADSP-21363 features six synchronous serial ports that provide an inexpensive interface to a wide variety of digital and mixed-signal peripheral devices such as Analog Devices' AD183x family of audio codecs, ADCs, and DACs. The serial ports are made up of two data lines, a clock and frame sync. The data lines can be programmed to either transmit or receive and each data line has a dedicated DMA channel.

Serial ports are enabled via 12 programmable and simultaneous receive or transmit pins that support up to 24 transmit or 24 receive channels of audio data when all six SPORTS are enabled, or six full duplex TDM streams of 128 channels per frame.

The serial ports operate at a maximum data rate of 50M bits/s. Serial port data can be automatically transferred to and from on-chip memory via dedicated DMA channels. Each of the serial ports can work in conjunction with another serial port to provide TDM support. One SPORT provides two transmit signals while the other SPORT provides the two receive signals. The frame sync and clock are shared.

Serial ports operate in four modes:

- Standard DSP serial mode
- Multichannel (TDM) mode
- I<sup>2</sup>S mode
- Left-justified sample pair mode

Left-justified sample pair mode is a mode where in each frame sync cycle two samples of data are transmitted/received—one sample on the high segment of the frame sync, the other on the low segment of the frame sync. Programs have control over various attributes of this mode.

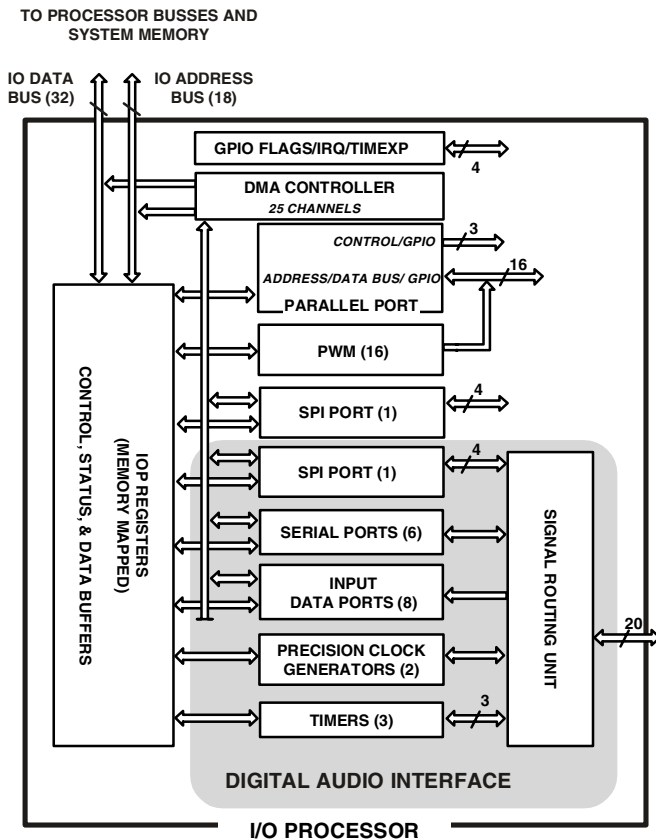

Figure 3. ADSP-21363 I/O Processor and Peripherals Block Diagram

Each of the serial ports supports the left-justified sample pair and I<sup>2</sup>S protocols (I<sup>2</sup>S is an industry standard interface commonly used by audio codecs, ADCs and DACs such as the Analog Devices AD183x family), with two data pins, allowing four left-justified sample pair or I<sup>2</sup>S channels (using two stereo devices) per serial port, with a maximum of up to 24 I<sup>2</sup>S channels. The serial ports permit little-endian or big-endian transmission formats and word lengths selectable from 3 bits to 32 bits. For the left-justified sample pair and I<sup>2</sup>S modes, data-word lengths are selectable between 8 bits and 32 bits. Serial ports offer selectable synchronization and transmit modes as well as optional  $\mu$ -law or A-law companding selection on a per channel basis. Serial port clocks and frame syncs can be internally or externally generated.

### Parallel Port

The Parallel Port provides interfaces to SRAM and peripheral devices. The multiplexed address and data pins (AD15–0) can access 8-bit devices with up to 24 bits of address, or 16-bit devices with up to 16 bits of address. In either mode, 8- or 16-bit, the maximum data transfer rate is 55M bytes/sec.

DMA transfers are used to move data to and from internal memory. Access to the core is also facilitated through the parallel port register read/write functions. The  $\overline{RD}$ ,  $\overline{WR}$ , and ALE (Address Latch Enable) pins are the control pins for the parallel port.

### Serial Peripheral (Compatible) Interface

The ADSP-21363 SHARC processor contains two Serial Peripheral Interface ports (SPIs). The SPI is an industry standard synchronous serial link, enabling the ADSP-21363 SPI compatible port to communicate with other SPI compatible devices. The SPI consists of two data pins, one device select pin, and one clock pin. It is a full-duplex synchronous serial interface, supporting both master and slave modes. The SPI port can operate in a multimaster environment by interfacing with up to four other SPI compatible devices, either acting as a master or slave device. The ADSP-21363 SPI compatible peripheral implementation also features programmable baud rate and clock phase and polarities. The ADSP-21363 SPI compatible port uses open drain drivers to support a multimaster configuration and to avoid data contention.

### Pulse Width Modulation

The PWM module is a flexible, programmable, PWM waveform generator that can be programmed to generate the required switching patterns for various applications related to motor and engine control or audio power control. The PWM generator can generate either center-aligned or edge-aligned PWM waveforms. In addition, it can generate complementary signals on two outputs in paired mode or independent signals in non paired mode (applicable to a single group of four PWM waveforms).

The entire PWM module has four groups of four PWM outputs each. Therefore this module generates 16 PWM outputs in total. Each PWM group produces two pairs of PWM signals on the four PWM outputs.

The PWM generator is capable of operating in two distinct modes while generating center-aligned PWM waveforms: single update mode, or double update mode. In single update mode the duty cycle values are programmable only once per PWM period. This results in PWM patterns that are symmetrical around the mid-point of the PWM period. In double update mode, a second updating of the PWM registers is implemented at the mid-point of the PWM period. In this mode, it is possible to produce asymmetrical PWM patterns that produce lower harmonic distortion in three-phase PWM inverters.

### Timers

The ADSP-21363 has a total of four timers: a core timer able to generate periodic software interrupts and three general purpose timers that can generate periodic interrupts and be independently set to operate in one of three modes:

- Pulse Waveform Generation mode
- Pulse Width Count /Capture mode
- External Event Watchdog mode

The core timer can be configured to use FLAG3 as a Timer Expired signal, and each general-purpose timer has one bidirectional pin and four registers that implement its mode of operation: a 6-bit configuration register, a 32-bit count register, a 32-bit period register, and a 32-bit pulse width register. A single control and status register enables or disables all three general purpose timers independently.

### Program Booting

The internal memory of the ADSP-21363 boots at system power-up from an 8-bit EPROM via the parallel port, an SPI master, an SPI slave or an internal boot. Booting is determined by the Boot Configuration (BOOTCFG1–0) pins. Selection of the boot source is controlled via the SPI as either a master or slave device.

### Phase-Locked Loop

The ADSP-21363 uses an on-chip Phase-Locked Loop (PLL) to generate the internal clock for the core. On power up, the CLKCFG1–0 pins are used to select ratios of 32:1, 16:1, and 6:1. After booting, numerous other ratios can be selected via software control. The ratios are made up of software configurable numerator values from 1 to 32 and software configurable divisor values of 1, 2, 4, 8, and 16.

### Power Supplies

The ADSP-21363 has separate power supply connections for the internal ( $V_{DDINT}$ ), external ( $V_{DDEXT}$ ), and analog ( $A_{VDD}/A_{VSS}$ ) power supplies. The internal and analog supplies must meet the 1.2 V requirement. The external supply must meet the 3.3 V requirement. All external supply pins must be connected to the same power supply.

Note that the analog supply ( $A_{VDD}$ ) powers the ADSP-21363's clock generator PLL. To produce a stable clock, programs should provide an external circuit to filter the power input to the  $A_{VDD}$  pin. Place the filter as close as possible to the pin. For an example circuit, see [Figure 4](#). To prevent noise coupling, use

a wide trace for the analog ground ( $A_{VSS}$ ) signal and install a decoupling capacitor as close as possible to the pin. Note that the  $A_{VSS}$  and  $A_{VDD}$  pins specified in Figure 4 are inputs to the processor and not the analog ground plane on the board.

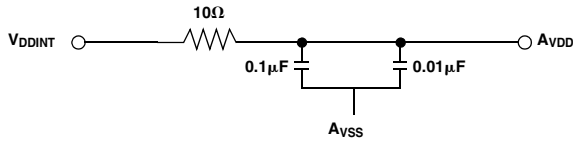

Figure 4. Analog Power ( $A_{VDD}$ ) Filter Circuit

### Target Board JTAG Emulator Connector

Analog Devices DSP Tools product line of JTAG emulators uses the IEEE 1149.1 JTAG test access port of the ADSP-21363 processor to monitor and control the target board processor during emulation. Analog Devices DSP Tools product line of JTAG emulators provides emulation at full processor speed, allowing inspection and modification of memory, registers, and processor stacks. The processor's JTAG interface ensures that the emulator will not affect target system loading or timing.

For complete information on Analog Devices' SHARC DSP Tools product line of JTAG emulator operation, see the appropriate "Emulator Hardware User's Guide".

### DEVELOPMENT TOOLS

The ADSP-21363 is supported with a complete set of CROSSCORE® software and hardware development tools, including Analog Devices emulators and VisualDSP++® development environment. The same emulator hardware that supports other SHARC processors also fully emulates the ADSP-21363.

The VisualDSP++ project management environment lets programmers develop and debug an application. This environment includes an easy to use assembler (which is based on an algebraic syntax), an archiver (librarian/library builder), a linker, a loader, a cycle-accurate instruction-level simulator, a C/C++ compiler, and a C/C++ runtime library that includes DSP and mathematical functions. A key point for these tools is C/C++ code efficiency. The compiler has been developed for efficient translation of C/C++ code to DSP assembly. The SHARC has architectural features that improve the efficiency of compiled C/C++ code.

The VisualDSP++ debugger has a number of important features. Data visualization is enhanced by a plotting package that offers a significant level of flexibility. This graphical representation of user data enables the programmer to quickly determine the performance of an algorithm. As algorithms grow in complexity, this capability can have increasing significance on the designer's development schedule, increasing productivity. Statistical profiling enables the programmer to non intrusively poll the processor as it is running the program. This feature, unique to VisualDSP++, enables the software developer to passively gather important code execution metrics without interrupting

the real-time characteristics of the program. Essentially, the developer can identify bottlenecks in software quickly and efficiently. By using the profiler, the programmer can focus on those areas in the program that impact performance and take corrective action.

Debugging both C/C++ and assembly programs with the VisualDSP++ debugger, programmers can:

- View mixed C/C++ and assembly code (interleaved source and object information)
- Insert breakpoints
- Set conditional breakpoints on registers, memory, and stacks
- Trace instruction execution
- Perform linear or statistical profiling of program execution
- Fill, dump, and graphically plot the contents of memory
- Perform source level debugging
- Create custom debugger windows

The VisualDSP++ IDE lets programmers define and manage DSP software development. Its dialog boxes and property pages let programmers configure and manage all of the SHARC development tools, including the color syntax highlighting in the VisualDSP++ editor. This capability permits programmers to:

- Control how the development tools process inputs and generate outputs
- Maintain a one-to-one correspondence with the tool's command line switches

The VisualDSP++ Kernel (VDK) incorporates scheduling and resource management tailored specifically to address the memory and timing constraints of DSP programming. These capabilities enable engineers to develop code more effectively, eliminating the need to start from the very beginning, when developing new application code. The VDK features include Threads, Critical and Unscheduled regions, Semaphores, Events, and Device flags. The VDK also supports Priority-based, Preemptive, Cooperative, and Time-Sliced scheduling approaches. In addition, the VDK was designed to be scalable. If the application does not use a specific feature, the support code for that feature is excluded from the target system.

Because the VDK is a library, a developer can decide whether to use it or not. The VDK is integrated into the VisualDSP++ development environment, but can also be used via standard command line tools. When the VDK is used, the development environment assists the developer with many error-prone tasks and assists in managing system resources, automating the generation of various VDK based objects, and visualizing the system state, when debugging an application that uses the VDK.

VisualDSP++ Component Software Engineering (VCSE) is Analog Devices' technology for creating, using, and reusing software components (independent modules of substantial functionality) to quickly and reliably assemble software applications. Download components from the Web and drop them into

the application. Publish component archives from within VisualDSP++. VCSE supports component implementation in C/C++ or assembly language.

Use the Expert Linker to visually manipulate the placement of code and data on the embedded system. View memory utilization in a color-coded graphical form, easily move code and data to different areas of the processor or external memory with the drag of the mouse, examine run time stack and heap usage. The Expert Linker is fully compatible with the existing Linker Definition File (LDF), allowing the developer to move between the graphical and textual environments.

In addition to the software and hardware development tools available from Analog Devices, third parties provide a wide range of tools supporting the SHARC processor family. Hardware tools include SHARC processor PC plug-in cards. Third party software tools include DSP libraries, real-time operating systems, and block diagram design tools.

### **Designing an Emulator-Compatible DSP Board (Target)**

The Analog Devices family of emulators are tools that every DSP developer needs to test and debug hardware and software systems. Analog Devices has supplied an IEEE 1149.1 JTAG Test Access Port (TAP) on each JTAG DSP. Nonintrusive in-circuit emulation is assured by the use of the processor's JTAG interface—the emulator does not affect target system loading or timing. The emulator uses the TAP to access the internal features of the processor, allowing the developer to load code, set breakpoints, observe variables, observe memory, and examine registers. The processor must be halted to send data and commands, but once an operation has been completed by the emulator, the processor system is set running at full speed with no impact on system timing.

To use these emulators, the target board must include a header that connects the processor's JTAG port to the emulator.

For details on target board design issues including mechanical layout, single processor connections, multiprocessor scan chains, signal buffering, signal termination, and emulator pod logic, see the *EE-68: Analog Devices JTAG Emulation Technical Reference* on the Analog Devices website ([www.analog.com](http://www.analog.com))—use site search on “EE-68.” This document is updated regularly to keep pace with improvements to emulator support.

### **Evaluation Kit**

Analog Devices offers a range of EZ-KIT Lite evaluation platforms to use as a cost effective method to learn more about developing or prototyping applications with Analog Devices processors, platforms, and software tools. Each EZ-KIT Lite includes an evaluation board along with an evaluation suite of the VisualDSP++ development and debugging environment with the C/C++ compiler, assembler, and linker. Also included are sample application programs, power supply, and a USB cable. All evaluation versions of the software tools are limited for use only with the EZ-KIT Lite product.

The USB controller on the EZ-KIT Lite board connects the board to the USB port of the user's PC, enabling the VisualDSP++ evaluation suite to emulate the on-board processor in-circuit. This permits the customer to download, execute, and

debug programs for the EZ-KIT Lite system. It also allows in-circuit programming of the on-board Flash device to store user-specific boot code, enabling the board to run as a standalone unit without being connected to the PC.

With a full version of VisualDSP++ installed (sold separately), engineers can develop software for the EZ-KIT Lite or any custom defined system. Connecting one of Analog Devices JTAG emulators to the EZ-KIT Lite board enables high-speed, non-intrusive emulation.

### **ADDITIONAL INFORMATION**

This data sheet provides a general overview of the ADSP-21363 architecture and functionality. For detailed information on the ADSP-2136x Family core architecture and instruction set, refer to the *ADSP-2136x SHARC Processor Hardware Reference* and the *ADSP-2136x SHARC Processor Programming Reference*.

## PIN FUNCTION DESCRIPTIONS

ADSP-21363 pin definitions are listed below. Inputs identified as synchronous (S) must meet timing requirements with respect to CLKIN (or with respect to TCK for TMS and TDI). Inputs identified as asynchronous (A) can be asserted asynchronously to CLKIN (or to TCK for  $\overline{\text{TRST}}$ ). Tie or pull unused inputs to  $V_{\text{DDEXT}}$  or GND, except for the following:

- DAI\_Px, SPICLK, MISO, MOSI,  $\overline{\text{EMU}}$ , TMS,  $\overline{\text{TRST}}$ , TDI, and AD15–0 (NOTE: These pins have pullup resistors.)

The following symbols appear in the Type column of Table 3: A = Asynchronous, G = Ground, I = Input, O = Output, P = Power Supply, S = Synchronous, (A/D) = Active Drive, (O/D) = Open Drain, and T = Three-State, (pd) = pulldown resistor, (pu) = pullup resistor.

Table 3. Pin Descriptions

Pin	Type	State During & After Reset	Function
AD15–0	I/O/T (pu)	Three-state with pullup enabled	<p><b>Parallel Port Address/Data.</b> The ADSP-21363 parallel port and its corresponding DMA unit output addresses and data for peripherals on these multiplexed pins. The multiplex state is determined by the ALE pin. The parallel port can operate in either 8-bit or 16-bit mode. Each AD pin has a 22.5 k<math>\Omega</math> internal pullup resistor. See <a href="#">Address Data Modes on Page 13</a> for details of the AD pin operation.</p> <p>For 8-bit mode: ALE is automatically asserted whenever a change occurs in the upper 16 external address bits, A23–8; ALE is used in conjunction with an external latch to retain the values of the A23–8.</p> <p>For 16-bit mode: ALE is automatically asserted whenever a change occurs in the address bits, A15–0; ALE is used in conjunction with an external latch to retain the values of the A15–0. To use these pins as flags (FLAGS15–0) or PWMs (PWM15–0), 1) set (=1) bit 20 of the SYSCTL register to disable the parallel port, 2) set (=1) bits 22–25 of the SYSCTL register to enable FLAGS in groups of four (bit 22 for FLAGS3–0, bit 23 for FLAGS7–4 etc.) or, set (=1) bits 26–29 of the SYSCTL register to enable PWMs in groups of four (bit 26 for PWM0–3, bit 27 for PWM4–7, and so on). When used as an input, the IDP Channel 0 can use these pins for parallel input data.</p>
$\overline{\text{RD}}$	O (pu)	Three-state, driven high <sup>1</sup>	<p><b>Parallel Port Read Enable.</b> <math>\overline{\text{RD}}</math> is asserted low whenever the processor reads 8-bit or 16-bit data from an external memory device. When AD15–0 are flags, this pin remains deasserted. <math>\overline{\text{RD}}</math> has a 22.5 k<math>\Omega</math> internal pullup resistor.</p>
$\overline{\text{WR}}$	O (pu)	Three-state, driven high <sup>1</sup>	<p><b>Parallel Port Write Enable.</b> <math>\overline{\text{WR}}</math> is asserted low whenever the processor writes 8-bit or 16-bit data to an external memory device. When AD15–0 are flags, this pin remains deasserted. <math>\overline{\text{WR}}</math> has a 22.5 k<math>\Omega</math> internal pullup resistor.</p>
ALE	O (pd)	Three-state, driven low <sup>1</sup>	<p><b>Parallel Port Address Latch enable.</b> ALE is asserted whenever the processor drives a new address on the parallel port address pins. On reset, ALE is active high. However, it can be reconfigured using software to be active low. When AD15–0 are flags, this pin remains deasserted. ALE has a 20 k<math>\Omega</math> internal pulldown resistor.</p>
FLAG3–0	I/O/A	Three-state	<p><b>Flag Pins.</b> Each flag pin is configured via control bits as either an input or output. As an input, it can be tested as a condition. As an output, it can be used to signal external peripherals. These pins can be used as an SPI interface slave select output during SPI mastering. These pins are also multiplexed with the <math>\overline{\text{IRQx}}</math> and the TIMEXP signals.</p> <p>In SPI master boot mode, FLAG0 is the slave select pin that must be connected to an SPI EPROM. FLAG0 is configured as a slave select during SPI master boot. When bit 16 is set (=1) in the SYSCTL register, FLAG0 is configured as <math>\overline{\text{IRQ0}}</math>.</p> <p>When bit 17 is set (=1) in the SYSCTL register, FLAG1 is configured as <math>\overline{\text{IRQ1}}</math>.</p> <p>When bit 18 is set (=1) in the SYSCTL register, FLAG2 is configured as <math>\overline{\text{IRQ2}}</math>.</p> <p>When bit 19 is set (=1) in the SYSCTL register, FLAG3 is configured as TIMEXP which indicates that the system timer has expired.</p>

Table 3. Pin Descriptions (Continued)

Pin	Type	State During & After Reset	Function
DAI_P20-1	I/O/T (pu)	Three-state with programmable pullup	<b>Digital Audio Interface Pins.</b> These pins provide the physical interface to the SRU. The SRU configuration registers define the combination of on-chip peripheral inputs or outputs connected to the pin and to the pin's output enable. The configuration registers of these peripherals then determines the exact behavior of the pin. Any input or output signal present in the SRU may be routed to any of these pins. The SRU provides the connection from the Serial ports, Input data port, precision clock generators and timers, and SPI to the DAI_P20-1 pins. These pins have internal 22.5 kΩ pullup resistors which are enabled on reset. These pullups can be disabled in the DAI_PIN_PULLUP register.
SPICLK	I/O (pu)	Three-state with pullup enabled	<b>Serial Peripheral Interface Clock Signal.</b> Driven by the master, this signal controls the rate at which data is transferred. The master may transmit data at a variety of baud rates. SPICLK cycles once for each bit transmitted. SPICLK is a gated clock that is active during data transfers, only for the length of the transferred word. Slave devices ignore the serial clock if the slave select input is driven inactive (HIGH). SPICLK is used to shift out and shift in the data driven on the MISO and MOSI lines. The data is always shifted out on one clock edge and sampled on the opposite edge of the clock. Clock polarity and clock phase relative to data are programmable into the SPICTL control register and define the transfer format. SPICLK has a 22.5 kΩ internal pullup resistor.
$\overline{\text{SPIDS}}$	I	Input only	<b>Serial Peripheral Interface Slave Device Select.</b> An active low signal used to select the processor as an SPI slave device. This input signal behaves like a chip select, and is provided by the master device for the slave devices. In multimaster mode the DSPs $\overline{\text{SPIDS}}$ signal can be driven by a slave device to signal to the processor (as SPI master) that an error has occurred, as some other device is also trying to be the master device. If asserted low when the device is in master mode, it is considered a multimaster error. For a single-master, multiple-slave configuration where flag pins are used, this pin must be tied or pulled high to $V_{DDEXT}$ on the master device. For ADSP-21363 to ADSP-21363 SPI interaction, any of the master ADSP-21363's flag pins can be used to drive the $\overline{\text{SPIDS}}$ signal on the ADSP-21363 SPI slave device.
MOSI	I/O (O/D) (pu)	Three-state with pullup enabled	<b>SPI Master Out Slave In.</b> If the ADSP-21363 is configured as a master, the MOSI pin becomes a data transmit (output) pin, transmitting output data. If the ADSP-21363 is configured as a slave, the MOSI pin becomes a data receive (input) pin, receiving input data. In an ADSP-21363 SPI interconnection, the data is shifted out from the MOSI output pin of the master and shifted into the MOSI input(s) of the slave(s). MOSI has a 22.5 kΩ internal pullup resistor.
MISO	I/O (O/D) (pu)	Three-state with pullup enabled	<b>SPI Master In Slave Out.</b> If the ADSP-21363 is configured as a master, the MISO pin becomes a data receive (input) pin, receiving input data. If the ADSP-21363 is configured as a slave, the MISO pin becomes a data transmit (output) pin, transmitting output data. In an ADSP-21363 SPI interconnection, the data is shifted out from the MISO output pin of the slave and shifted into the MISO input pin of the master. MISO has a 22.5 kΩ internal pullup resistor. MISO can be configured as O/D by setting the OPD bit in the SPICTL register. <b>Note:</b> Only one slave is allowed to transmit data at any given time. To enable broadcast transmission to multiple SPI-slaves, the processor's MISO pin may be disabled by setting (=1) bit 5 (DMISO) of the SPICTL register.
BOOTCFG1-0	I	Input only	<b>Boot Configuration Select.</b> This pin is used to select the boot mode for the processor. The BOOTCFG pins must be valid before reset is asserted. See Table 5 for a description of the boot modes.

Table 3. Pin Descriptions (Continued)

Pin	Type	State During & After Reset	Function
CLKIN	I	Input only	<b>Local Clock In.</b> Used in conjunction with XTAL. CLKIN is the ADSP-21363 clock input. It configures the ADSP-21363 to use either its internal clock generator or an external clock source. Connecting the necessary components to CLKIN and XTAL enables the internal clock generator. Connecting the external clock to CLKIN while leaving XTAL unconnected configures the ADSP-21363 to use the external clock source such as an external clock oscillator. The core is clocked either by the PLL output or this clock input depending on the CLKCFG1–0 pin settings. CLKIN may not be halted, changed, or operated below the specified frequency.
XTAL	O	Output only <sup>2</sup>	<b>Crystal Oscillator Terminal.</b> Used in conjunction with CLKIN to drive an external crystal.
CLKCFG1–0	I	Input only	<b>Core/CLKIN Ratio Control.</b> These pins set the start up clock frequency. See <a href="#">Table 6</a> for a description of the clock configuration modes. Note that the operating frequency can be changed by programming the PLL multiplier and divider in the PMCTL register at any time after the core comes out of reset.
$\overline{\text{RSTOUT}}/\text{CLKOUT}$	O	Output only	<b>Local Clock Out/ Reset Out.</b> Drives out the core reset signal to an external device. CLKOUT can also be configured as a reset out pin. The functionality can be switched between the PLL output clock and reset out by setting bit 12 of the PMCTREG register. The default is reset out.
$\overline{\text{RESET}}$	I/A	Input only	<b>Processor Reset.</b> Resets the ADSP-21363 to a known state. Upon deassertion, there is a 4096 CLKIN cycle latency for the PLL to lock. After this time, the core begins program execution from the hardware reset vector address. The $\overline{\text{RESET}}$ input must be asserted (low) at power-up.
TCK	I	Input only <sup>3</sup>	<b>Test Clock (JTAG).</b> Provides a clock for JTAG boundary scan. TCK must be asserted (pulsed low) after power-up or held low for proper operation of the ADSP-21363.
TMS	I/S (pu)	Three-state with pullup enabled	<b>Test Mode Select (JTAG).</b> Used to control the test state machine. TMS has a 22.5 k $\Omega$ internal pullup resistor.
TDI	I/S (pu)	Three-state with pullup enabled	<b>Test Data Input (JTAG).</b> Provides serial data for the boundary scan logic. TDI has a 22.5 k $\Omega$ internal pullup resistor.
TDO	O	Three-state <sup>4</sup>	<b>Test Data Output (JTAG).</b> Serial scan output of the boundary scan path.
$\overline{\text{TRST}}$	I/A (pu)	Three-state with pullup enabled	<b>Test Reset (JTAG).</b> Resets the test state machine. $\overline{\text{TRST}}$ must be asserted (pulsed low) after power-up or held low for proper operation of the ADSP-21363. $\overline{\text{TRST}}$ has a 22.5 k $\Omega$ internal pullup resistor.
$\overline{\text{EMU}}$	O (O/D) (pu)	Three-state with pullup enabled	<b>Emulation Status.</b> Must be connected to the ADSP-21363 Analog Devices DSP Tools product line of JTAG emulators target board connector only. $\overline{\text{EMU}}$ has a 22.5 k $\Omega$ internal pullup resistor.
V <sub>DDINT</sub>	P		<b>Core Power Supply.</b> Nominally +1.2 V dc and supplies the processor's core (13 pins on the Mini-BGA package, 32 pins on the LQFP package).
V <sub>DDEXT</sub>	P		<b>I/O Power Supply.</b> Nominally +3.3 V dc. (6 pins on the Mini-BGA package, 10 pins on the LQFP package).
A <sub>VDD</sub>	P		<b>Analog Power Supply.</b> Nominally +1.2 V dc and supplies the processor's internal PLL (clock generator). This pin has the same specifications as V <sub>DDINT</sub> , except that added filtering circuitry is required. <a href="#">For more information, see Power Supplies on Page 7.</a>
A <sub>VSS</sub>	G		<b>Analog Power Supply Return.</b>
GND	G		<b>Power Supply Return.</b> (54 pins on the Mini-BGA package, 39 pins on the LQFP package).

<sup>1</sup>  $\overline{\text{RD}}$ ,  $\overline{\text{WR}}$ , and ALE are three-stated (and not driven) only when  $\overline{\text{RESET}}$  is active.<sup>2</sup> Output only is a three-state driver with its output path always enabled.<sup>3</sup> Input only is a three-state driver with both output path and pullup disabled.<sup>4</sup> Three-state is a three-state driver with pullup disabled.

**ADDRESS DATA PINS AS FLAGS**

To use these pins as flags (FLAGS15–0) set (=1) bit 20 of the SYSCCTL register to disable the parallel port. Then set (=1) bits 22 to 25 in the SYSCCTL register accordingly.

**Table 4. AD15–0 to Flag Pin Mapping**

AD Pin	Flag Pin
AD0	FLAG8
AD1	FLAG9
AD2	FLAG10
AD3	FLAG11
AD4	FLAG12
AD5	FLAG13
AD6	FLAG14
AD7	FLAG15
AD8	FLAG0
AD9	FLAG1
AD10	FLAG2
AD11	FLAG3
AD12	FLAG4
AD13	FLAG5
AD14	FLAG6
AD15	FLAG7

**BOOT MODES**

**Table 5. Boot Mode Selection**

BOOTCFG1–0	Booting Mode
00	SPI Slave Boot
01	SPI Master Boot
10	Parallel Port boot via EPROM

**CORE INSTRUCTION RATE TO CLKIN RATIO MODES**

For details on processor timing, see [Timing Specifications](#) and [Figure 5 on Page 16](#).

**Table 6. Core Instruction Rate/ CLKIN Ratio Selection**

CLKCFG1–0	Core to CLKIN Ratio
00	6:1
01	32:1
10	16:1

**ADDRESS DATA MODES**

The following table shows the functionality of the AD pins for 8-bit and 16-bit transfers to the parallel port. For 8-bit data transfers, ALE latches address bits A23–A8 when asserted, followed by address bits A7–A0 and data bits D7–D0 when deasserted. For 16-bit data transfers, ALE latches address bits A15–A0 when asserted, followed by data bits D15–D0 when deasserted.

**Table 7. Address/ Data Mode Selection**

EP Data Mode	ALE	AD7–0 Function	AD15–8 Function
8-bit	Asserted	A15–8	A23–16
8-bit	Deasserted	D7–0	A7–0
16-bit	Asserted	A7–0	A15–8
16-bit	Deasserted	D7–0	D15–8

## ADSP-21363 SPECIFICATIONS

## RECOMMENDED OPERATING CONDITIONS

Parameter <sup>1</sup>		K Grade		B Grade		C Grade		Unit
		Min	Max	Min	Max	Min	Max	
V <sub>DDINT</sub>	Internal (Core) Supply Voltage	1.14	1.26	1.14	1.26	0.95	1.05	V
A <sub>VDD</sub>	Analog (PLL) Supply Voltage	1.14	1.26	1.14	1.26	0.95	1.05	V
V <sub>DDEXT</sub>	External (I/O) Supply Voltage	3.13	3.47	3.13	3.47	3.13	3.47	V
V <sub>IH</sub> <sup>2</sup>	High Level Input Voltage @ V <sub>DDEXT</sub> = max	2.0	V <sub>DDEXT</sub> + 0.5	2.0	V <sub>DDEXT</sub> + 0.5	2.0	V <sub>DDEXT</sub> + 0.5	V
V <sub>IL</sub> <sup>2</sup>	Low Level Input Voltage @ V <sub>DDEXT</sub> = min	-0.5	+0.8	-0.5	+0.8	-0.5	+0.8	V
V <sub>IH_CLKIN</sub> <sup>3</sup>	High Level Input Voltage @ V <sub>DDEXT</sub> = max	1.74	V <sub>DDEXT</sub> + 0.5	1.74	V <sub>DDEXT</sub> + 0.5	1.74	V <sub>DDEXT</sub> + 0.5	V
V <sub>IL_CLKIN</sub>	Low Level Input Voltage @ V <sub>DDEXT</sub> = min	-0.5	+1.19	-0.5	+1.19	-0.5	+1.19	V
T <sub>AMB</sub> <sup>4,5</sup>	Ambient Operating Temperature	0	+70	-40	+85	-40	+105	°C

<sup>1</sup> Specifications subject to change without notice.

<sup>2</sup> Applies to input and bidirectional pins: AD15-0, FLAG3-0, DAI\_Px, SPICLK, MOSI, MISO,  $\overline{\text{SPIDS}}$ ,  $\overline{\text{BOOTCFGx}}$ ,  $\overline{\text{CLKCFGx}}$ ,  $\overline{\text{RESET}}$ , TCK, TMS, TDI,  $\overline{\text{TRST}}$ .

<sup>3</sup> Applies to input pin CLKIN.

<sup>4</sup> See [Thermal Characteristics on Page 37](#) for information on thermal specifications.

<sup>5</sup> See Engineer-to-Engineer Note (No. TBD) for further information.

## ELECTRICAL CHARACTERISTICS

Parameter <sup>1</sup>	Test Conditions	Min	Max	Unit
V <sub>OH</sub> <sup>2</sup>	High Level Output Voltage	2.4		V
V <sub>OL</sub> <sup>2</sup>	Low Level Output Voltage		0.4	V
I <sub>IH</sub> <sup>4,5</sup>	High Level Input Current		10	μA
I <sub>IL</sub> <sup>4</sup>	Low Level Input Current		10	μA
I <sub>ILPU</sub> <sup>5</sup>	Low Level Input Current Pullup		200	μA
I <sub>OZH</sub> <sup>6,7</sup>	Three-State Leakage Current		10	μA
I <sub>OZL</sub> <sup>6</sup>	Three-State Leakage Current		10	μA
I <sub>OZLPU</sub> <sup>7</sup>	Three-State Leakage Current Pullup		200	μA
I <sub>DD-INTYP</sub> <sup>8,9</sup>	Supply Current (Internal)		500	mA
A <sub>IDD</sub> <sup>10</sup>	Supply Current (Analog)		10	mA
C <sub>IN</sub> <sup>11,12</sup>	Input Capacitance		4.7	pF

<sup>1</sup> Specifications subject to change without notice.

<sup>2</sup> Applies to output and bidirectional pins: AD15-0,  $\overline{\text{RD}}$ ,  $\overline{\text{WR}}$ , ALE, FLAG3-0, DAI\_Px, SPICLK, MOSI, MISO,  $\overline{\text{EMU}}$ , TDO, CLKOUT, XTAL.

<sup>3</sup> See [Output Drive Currents on Page 36](#) for typical drive current capabilities.

<sup>4</sup> Applies to input pins:  $\overline{\text{SPIDS}}$ ,  $\overline{\text{BOOTCFGx}}$ ,  $\overline{\text{CLKCFGx}}$ , TCK,  $\overline{\text{RESET}}$ , CLKIN.

<sup>5</sup> Applies to input pins with 22.5 kΩ internal pullups:  $\overline{\text{TRST}}$ , TMS, TDI.

<sup>6</sup> Applies to three-statable pins: FLAG3-0.

<sup>7</sup> Applies to three-statable pins with 22.5 kΩ pullups: AD15-0, DAI\_Px,  $\overline{\text{SPICLK}}$ ,  $\overline{\text{EMU}}$ , MISO, MOSI.

<sup>8</sup> Typical internal current data reflects nominal operating conditions.

<sup>9</sup> See Engineer-to-Engineer Note (No. TBD) for further information.

<sup>10</sup> Characterized, but not tested.

<sup>11</sup> Applies to all signal pins.

<sup>12</sup> Guaranteed, but not tested.

**MAXIMUM POWER DISSIPATION**

The data in this table is based on theta JA ( $\theta_{JA}$ ) established per JEDEC standards JESD51-2 and JESD51-6. See Engineer-to-Engineer note (EE-TBD) for further information. For information on package thermal specifications, see [Thermal Characteristics on Page 37](#).

Max Ambient Temp <sup>1</sup>	144 INT-HS LQFP <sup>2</sup>	144 INT-HS LQFP <sup>3</sup>	136 Mini-BGA <sup>4</sup>	136 Mini-BGA <sup>5</sup>
70°C	3.33W	2.10W	2.44W	2.18W
85°C	2.42W	N/A	1.77W	N/A
105°C	1.21W	N/A	N/A	N/A

<sup>1</sup>Power Dissipation greater than that listed above may cause permanent damage to the device. For more information, see [Thermal Characteristics on Page 37](#).

<sup>2</sup>Heat slug soldered to PCB

<sup>3</sup>Heat slug not soldered to PCB

<sup>4</sup>Thermal vias in PCB

<sup>5</sup>No thermal vias in PCB

**ABSOLUTE MAXIMUM RATINGS**

Parameter	Rating
Internal (Core) Supply Voltage ( $V_{DDINT}$ ) <sup>1</sup>	-0.3 V to +1.5 V
Analog (PLL) Supply Voltage ( $A_{VDD}$ ) <sup>1</sup>	-0.3 V to +1.5 V
External (I/O) Supply Voltage ( $V_{DDEXT}$ ) <sup>1</sup>	-0.3 V to +4.6 V
Input Voltage -0.5 V to $V_{DDEXT}$ <sup>1</sup>	+ 0.5 V
Output Voltage Swing -0.5 V to $V_{DDEXT}$ <sup>1</sup>	+ 0.5 V
Load Capacitance <sup>1</sup>	200 pF
Storage Temperature Range <sup>1</sup>	-65°C to +150°C
Junction Temperature under Bias	125°C

<sup>1</sup>Stresses greater than those listed above may cause permanent damage to the device. These are stress ratings only; functional operation of the device at these or any other conditions greater than those indicated in the operational sections of this specification is not implied. Exposure to absolute maximum rating conditions for extended periods may affect device reliability.

**ESD SENSITIVITY**

**CAUTION**

ESD (electrostatic discharge) sensitive device. Electrostatic charges as high as 4000V readily accumulate on the human body and test equipment and can discharge without detection. Although the ADSP-21363 features proprietary ESD protection circuitry, permanent damage may occur on devices subjected to high-energy electrostatic discharges. Therefore, proper ESD precautions are recommended to avoid performance degradation or loss of functionality.



**TIMING SPECIFICATIONS**

The ADSP-21363’s internal clock (a multiple of CLKIN) provides the clock signal for timing internal memory, processor core, serial ports, and parallel port (as required for read/write strobes in asynchronous access mode). During reset, program the ratio between the processor’s internal clock frequency and external (CLKIN) clock frequency with the CLKCFG1-0 pins.

To determine switching frequencies for the serial ports, divide down the internal clock, using the programmable divider control of each port (DIVx for the serial ports).

The ADSP-21363’s internal clock switches at higher frequencies than the system input clock (CLKIN). To generate the internal clock, the processor uses an internal phase-locked loop (PLL). This PLL-based clocking minimizes the skew between the system clock (CLKIN) signal and the processor’s internal clock (the clock source for the parallel port logic and I/O pads).

Note the definitions of various clock periods that are a function of CLKIN and the appropriate ratio control (Table 8).

**Table 8. ADSP-21363 CLKOUT and CCLK Clock Generation Operation**

Timing Requirements	Description	Calculation
CLKIN	Input Clock	$1/t_{CK}$
CCLK	Core Clock	$1/t_{CCLK}$

**Table 9. Clock Periods**

Timing Requirements	Description <sup>1</sup>
$t_{CK}$	CLKIN Clock Period
$t_{CCLK}$	(Processor) Core Clock Period
$t_{PCLK}$	(Peripheral) Clock Period = $2 \times t_{CCLK}$
$t_{SCLK}$	Serial Port Clock Period = $(t_{PCLK}) \times SR$
$t_{SPICLK}$	SPI Clock Period = $(t_{PCLK}) \times SPIR$

<sup>1</sup> where:

- SR = serial port-to-core clock ratio (wide range, determined by SPORT CLKDIV)
- SPIR = SPI-to-Core Clock Ratio (wide range, determined by SPIBAUD register)
- DAI\_Px = Serial Port Clock
- SPICLK = SPI Clock

Figure 5 shows Core to CLKIN ratios of 6:1, 16:1 and 32:1 with external oscillator or crystal. Note that more ratios are possible and can be set through software using the power management control register (PMCTL). For more information, see the ADSP-2136x SHARC Processor Programming Reference.

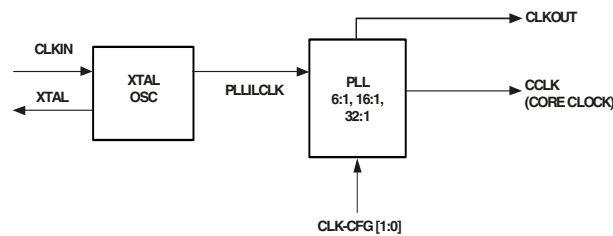

Figure 5. Core Clock and System Clock Relationship to CLKIN

Use the exact timing information given. Do not attempt to derive parameters from the addition or subtraction of others. While addition or subtraction would yield meaningful results for an individual device, the values given in this data sheet reflect statistical variations and worst cases. Consequently, it is not meaningful to add parameters to derive longer times. See Figure 30 on page 36 under Test Conditions for voltage reference levels.

Switching characteristics specify how the processor changes its signals. Circuitry external to the processor must be designed for compatibility with these signal characteristics. Switching characteristics describe what the processor will do in a given circumstance. Use switching characteristics to ensure that any timing requirement of a device connected to the processor (such as memory) is satisfied.

Timing requirements apply to signals that are controlled by circuitry external to the processor, such as the data input for a read operation. Timing requirements guarantee that the processor operates correctly with other devices.

**Power-Up Sequencing**

The timing requirements for processor startup are given in [Table 10](#).

**Table 10. Power-Up Sequencing Timing Requirements (Processor Startup)**

Parameter		Min	Max	Unit
<i>Timing Requirements</i>				
t <sub>RSTVDD</sub>	$\overline{\text{RESET}}$ Low Before V <sub>DDINT</sub> /V <sub>DDEXT</sub> on	0		ns
t <sub>IVDDEVDD</sub>	V <sub>DDINT</sub> on Before V <sub>DDEXT</sub>	-50	200	ms
t <sub>CLKVDD</sub> <sup>1</sup>	CLKIN Valid After V <sub>DDINT</sub> /V <sub>DDEXT</sub> Valid	0	200	ms
t <sub>CLKRST</sub>	CLKIN Valid Before $\overline{\text{RESET}}$ Deasserted	10 <sup>2</sup>		μs
t <sub>PLLST</sub>	PLL Control Setup Before $\overline{\text{RESET}}$ Deasserted	20 <sup>3</sup>		μs
<i>Switching Characteristic</i>				
t <sub>CORERST</sub>	Core Reset Deasserted After $\overline{\text{RESET}}$ Deasserted	4096t <sub>CK</sub> + 2 t <sub>CCLK</sub> <sup>4,5</sup>		

<sup>1</sup> Valid V<sub>DDINT</sub>/V<sub>DDEXT</sub> assumes that the supplies are fully ramped to their 1.2 and 3.3 volt rails. Voltage ramp rates can vary from microseconds to hundreds of milliseconds depending on the design of the power supply subsystem.

<sup>2</sup> Assumes a stable CLKIN signal, after meeting worst-case startup timing of crystal oscillators. Refer to your crystal oscillator manufacturer's datasheet for startup time. Assume a 25 ms maximum oscillator startup time if using the XTAL pin and internal oscillator circuit in conjunction with an external crystal.

<sup>3</sup> Based on CLKIN cycles

<sup>4</sup> Applies after the power-up sequence is complete. Subsequent resets require a minimum of 4 CLKIN cycles for  $\overline{\text{RESET}}$  to be held low in order to properly initialize and propagate default states at all I/O pins.

<sup>5</sup> The 4096 cycle count depends on t<sub>RST</sub> specification in [Table 12](#). If setup time is not met, 1 additional CLKIN cycle may be added to the core reset time, resulting in 4097 cycles maximum.

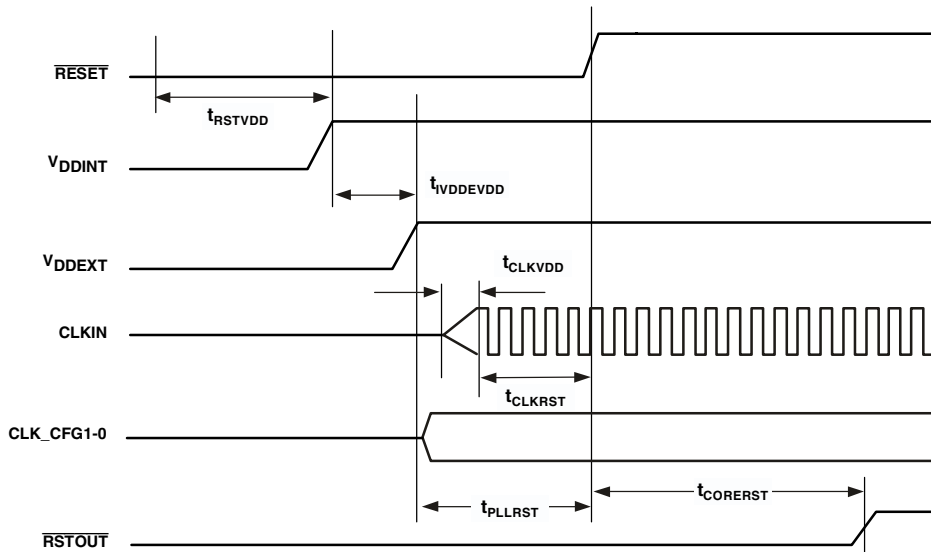

Figure 6. Power Up Sequencing

## Clock Input

Table 11. Clock Input

Parameter	333 MHz		Unit	
	Min	Max		
<i>Timing Requirements</i>				
t <sub>CK</sub>	CLKIN Period	18 <sup>1</sup>	TBD <sup>2</sup>	ns
t <sub>CKL</sub>	CLKIN Width Low	7.5 <sup>1</sup>	TBD <sup>2</sup>	ns
t <sub>CKH</sub>	CLKIN Width High	7.5 <sup>1</sup>	TBD <sup>2</sup>	ns
t <sub>CKRF</sub>	CLKIN Rise/Fall (0.4V–2.0V)		TBD	ns
t <sub>CCLK</sub> <sup>3</sup>	CCLK Period	3.0 <sup>1</sup>	TBD	ns

<sup>1</sup>Applies only for CLKCFG1-0 = 00 and default values for PLL control bits in PMCTL.

<sup>2</sup>Applies only for CLKCFG1-0 = 01 and default values for PLL control bits in PMCTL.

<sup>3</sup>Any changes to PLL control bits in the PMCTL register must meet core clock timing specification t<sub>CCLK</sub>.

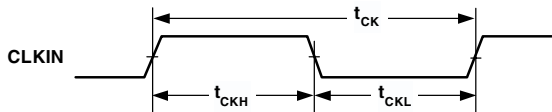
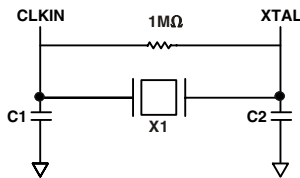

Figure 7. Clock Input

## Clock Signals

The ADSP-21363 can use an external clock or a crystal. See CLKIN pin description in [Table 3 on Page 10](#). The programmer can configure the ADSP-21363 to use its internal clock generator by connecting the necessary components to CLKIN and XTAL. [Figure 8](#) shows the component connections used for a crystal operating in fundamental mode. Note that the clock rate is achieved using a 16.67 MHz crystal and a PLL multiplier ratio 16:1 (CCLK:CLKIN achieves a clock speed of 266 MHz). To achieve the full core clock rate, programs need to configure the multiplier bits in the PMCTL register.



NOTE: C1 AND C2 ARE SPECIFIC TO CRYSTAL SPECIFIED FOR X1. CONTACT CRYSTAL MANUFACTURER FOR DETAILS. CRYSTAL SELECTION MUST COMPLY WITH CLKCFG1-0 = 10 OR = 01.

Figure 8. 333 MHz Operation (Fundamental Mode Crystal)

**Reset**

**Table 12. Reset**

Parameter	Min	Max	Unit
<i>Timing Requirements</i>			
$t_{WRST}^1$ $\overline{RESET}$ Pulse Width Low	$4t_{CK}$		ns
$t_{SRST}$ $\overline{RESET}$ Setup Before CLKIN Low	8		ns

<sup>1</sup> Applies after the power-up sequence is complete. At power-up, the processor's internal phase-locked loop requires no more than 100  $\mu$ s while  $\overline{RESET}$  is low, assuming stable VDD and CLKIN (not including start-up time of external clock oscillator).

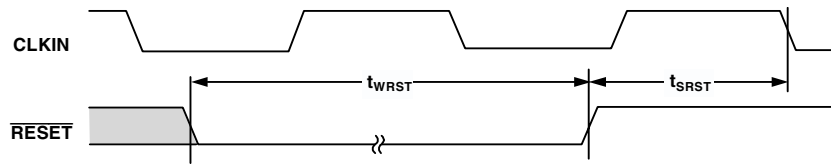

Figure 9. Reset

**Interrupts**

The following timing specification applies to the FLAG0, FLAG1, and FLAG2 pins when they are configured as  $\overline{IRQ0}$ ,  $\overline{IRQ1}$ , and  $\overline{IRQ2}$  interrupts. Also applies to DAI\_P20-1 pins when configured as interrupts

**Table 13. Interrupts**

Parameter	Min	Max	Unit
<i>Timing Requirement</i>			
$t_{IPW}$ $\overline{IRQx}$ Pulse Width	$2 \times t_{pCLK} + 2$		ns

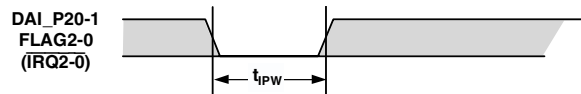

Figure 10. Interrupts

**Core Timer**

The following timing specification applies to FLAG3 when it is configured as the core timer (CTIMER).

**Table 14. Core Timer**

Parameter	Min	Max	Unit
<i>Switching Characteristic</i>			
$t_{WCTIM}$ CTIMER Pulse Width	$4 \times t_{PCLK} - 1$		ns

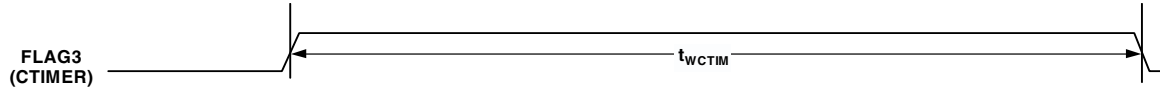

Figure 11. Core Timer

**Timer PWM\_OUT Cycle Timing**

The following timing specification applies to Timer0, Timer1, and Timer2 in PWM\_OUT (pulse width modulation) mode. Timer signals are routed to the DAI\_P20-1 pins through the SRU. Therefore, the timing specifications provided below are valid at the DAI\_P20-1 pins.

**Table 15. Timer PWM\_OUT Timing**

Parameter	Min	Max	Unit
<i>Switching Characteristic</i>			
$t_{PWMO}$ Timer Pulse Width Output	$2 t_{PCLK} - 1$	$2(2^{31} - 1) t_{PCLK}$	ns

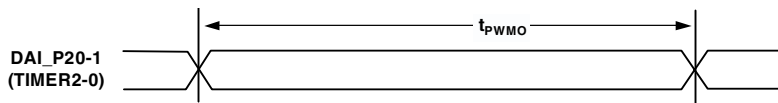

Figure 12. Timer PWM\_OUT Timing

**Timer WDT<sub>H</sub>\_CAP Timing**

The following timing specification applies to Timer0, Timer1, and Timer2 in WDT<sub>H</sub>\_CAP (pulse width count and capture) mode. Timer signals are routed to the DAI\_P20-1 pins through the SRU. Therefore, the timing specifications provided below are valid at the DAI\_P20-1 pins.

**Table 16. Timer Width Capture Timing**

Parameter	Min	Max	Unit
<i>Timing Requirement</i>			
t <sub>PWI</sub> Timer Pulse Width	2 t <sub>PCLK</sub>	2(2 <sup>31</sup> - 1) t <sub>PCLK</sub>	ns

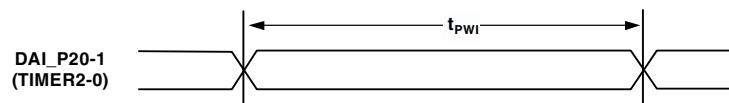

Figure 13. Timer Width Capture Timing

**DAI Pin to Pin Direct Routing**

For direct pin connections only (for example DAI\_PB01\_I to DAI\_PB02\_O).

**Table 17. DAI Pin to Pin Routing**

Parameter	Min	Max	Unit
<i>Timing Requirement</i>			
t <sub>DPIO</sub> Delay DAI Pin Input Valid to DAI Output Valid	1.5	10	ns

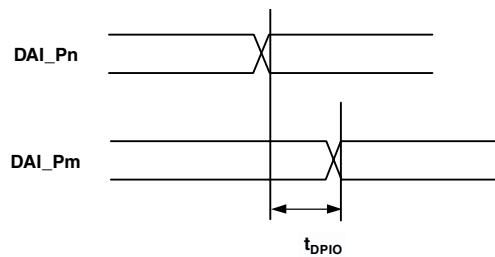

Figure 14. DAI Pin to PIN Direct Routing

**Precision Clock Generator (Direct Pin Routing)**

This timing is only valid when the SRU is configured such that the Precision Clock Generator (PCG) takes its inputs directly from the DAI pins (via pin buffers) and sends its outputs directly to the DAI pins. For the other cases, where the PCG's

inputs and outputs are not directly routed to/from DAI pins (via pin buffers) there is not timing data available. All Timing Parameters and Switching Characteristics apply to external DAI pins (DAI\_P07 – DAI\_P20).

**Table 18. Precision Clock Generator (Direct Pin Routing)**

Parameter		Min	Max	Unit
<i>Timing Requirements</i>				
$t_{PCGIW}$	Input Clock Period	24		
$t_{STRIG}$	PCG Trigger Setup Before Falling Edge of PCG Input Clock	2		ns
$t_{HTRIG}$	PCG Trigger Hold After Falling Edge of PCG Input Clock	2		ns
<i>Switching Characteristics</i>				
$t_{DPCGIO}$	PCG Output Clock and Frame Sync Active Edge Delay After PCG Input Clock	2.5	10	ns
$t_{DTRIG}$	PCG Output Clock and Frame Sync Delay After PCG Trigger	$2.5 + 2.5 \times t_{PCGOW}$	$10 + 2.5 \times t_{PCGOW}$	ns
$t_{PCGOW}$	Output Clock Period	48		

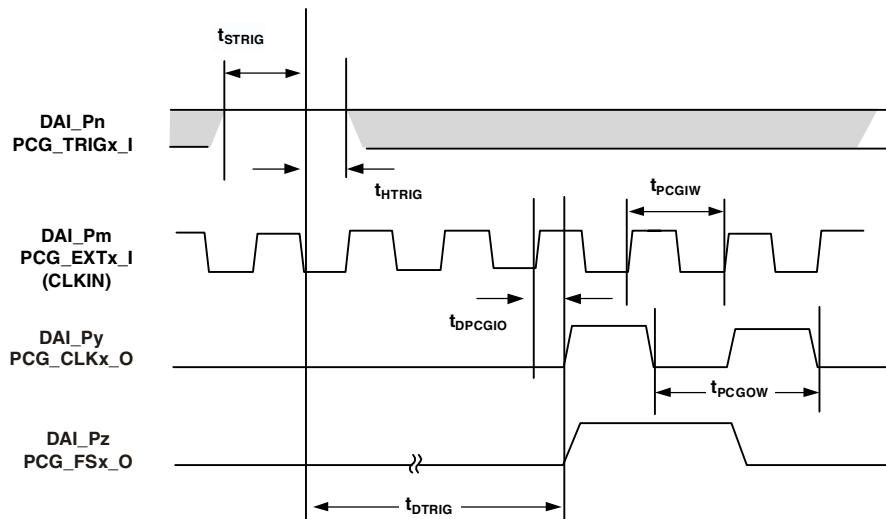

Figure 15. Precision Clock Generator (Direct Pin Routing)

**Flags**

The timing specifications provided below apply to the FLAG3-0 and DAI\_P20-1 pins, the parallel port and the serial peripheral interface (SPI). See [Table 3, “Pin Descriptions,” on page 10](#) for more information on flag use.

**Table 19. Flags**

Parameter	Min	Max	Unit
<i>Timing Requirement</i>			
$t_{FIPW}$ FLAG3-0 IN Pulse Width	$2 \times t_{PCLK} + 3$		ns
<i>Switching Characteristic</i>			
$t_{FOPW}$ FLAG3-0 OUT Pulse Width	$2 \times t_{PCLK} - 1$		ns

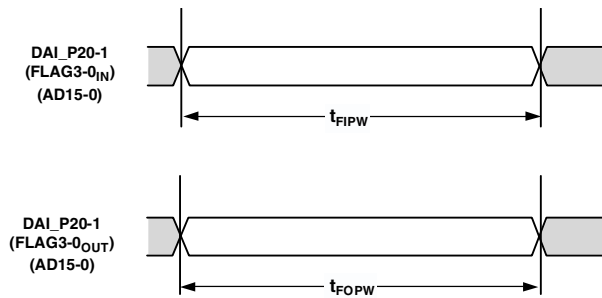

Figure 16. Flags

**Memory Read—Parallel Port**

Use these specifications for asynchronous interfacing to memories (and memory-mapped peripherals) when the ADSP-21363 is accessing external memory space.

**Table 20. 8-Bit Memory Read Cycle**

Parameter		Min	Max	Unit
<i>Timing Requirements</i>				
t <sub>DRS</sub>	Address/Data 7–0 Setup Before $\overline{RD}$ High	3.3		ns
t <sub>DRH</sub>	Address/Data 7–0 Hold After $\overline{RD}$ High	0		ns
t <sub>DAD</sub>	Address 15–8 to Data Valid		D + t <sub>pCLK</sub> – 5	ns
<i>Switching Characteristics</i>				
t <sub>ALEW</sub>	ALE Pulse Width	2 × t <sub>pCLK</sub> – 2.0		ns
t <sub>ADAS</sub> <sup>1</sup>	Address/Data 15–0 Setup Before ALE Deasserted	t <sub>pCLK</sub> – 2.5		ns
t <sub>RRH</sub>	Delay Between $\overline{RD}$ Rising Edge to Next Falling Edge.	H + t <sub>pCLK</sub> – 1		ns
t <sub>ALERW</sub>	ALE Deasserted to Read Asserted	2 × t <sub>pCLK</sub> – 2		ns
t <sub>rwALE</sub>	Read Deasserted to ALE Asserted	F + H + 0.5		ns
t <sub>ADAH</sub> <sup>1</sup>	Address/Data 15–0 Hold After ALE Deasserted	t <sub>pCLK</sub> – 0.8		ns
t <sub>ALEHZ</sub> <sup>1</sup>	ALE Deasserted to Address/Data 7–0 in High Z	t <sub>pCLK</sub> – 0.8	t <sub>pCLK</sub>	ns
t <sub>rw</sub>	$\overline{RD}$ Pulse Width	D – 2		ns
t <sub>RDDRv</sub>	$\overline{RD}$ Address Drive After Read High	F + H + t <sub>pCLK</sub> – 1		ns
t <sub>ADRH</sub>	Address/Data 15–8 Hold After $\overline{RD}$ High	H		ns

D = (Data Cycle Duration = the value set by the PPDUR bits (5–1) in the PPCTL register) × t<sub>pCLK</sub>

H = t<sub>pCLK</sub> (if a hold cycle is specified, else H = 0)

F = 7 × t<sub>pCLK</sub> (if FLASH\_MODE is set else F = 0)

t<sub>pCLK</sub> = (Peripheral) Clock Period = 2 × t<sub>cCLK</sub>

<sup>1</sup> On reset, ALE is an active high cycle. However, it can be configured by software to be active low.

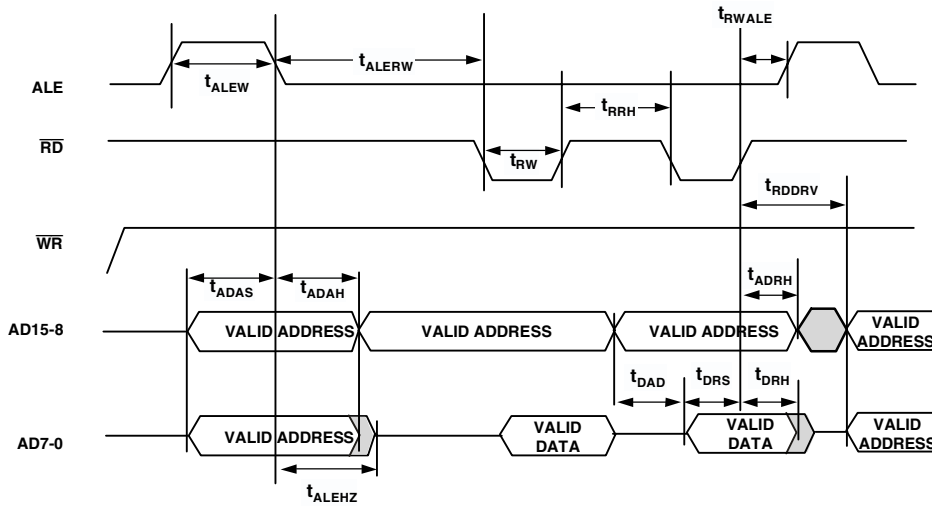

Figure 17. Read Cycle For 8-Bit Memory Timing

Table 21. 16-bit Memory Read Cycle

Parameter		Min	Max	Unit
<i>Timing Requirements</i>				
$t_{DRS}$	Address/Data 15-0 Setup Before $\overline{RD}$ High	3.3		ns
$t_{DRH}$	Address/Data 15-0 Hold After $\overline{RD}$ High	0		ns
<i>Switching Characteristics</i>				
$t_{ALEW}$	ALE Pulse Width	$2 \times t_{PCLK} - 2$		ns
$t_{ADAS}^1$	Address/Data 15-0 Setup Before ALE Deasserted	$t_{PCLK} - 2.5$		ns
$t_{ALERW}$	ALE Deasserted to Read Asserted	$2 \times t_{PCLK} - 2$		ns
$t_{RRH}$	Delay Between $\overline{RD}$ Rising Edge to Next Falling Edge.	$H + t_{PCLK} - 1$		ns
$t_{RWALE}$	Read Deasserted to ALE Asserted	$F + H + 0.5$		ns
$t_{RDDR}$	$\overline{RD}$ Address Drive After Read High	$F + H + t_{PCLK} - 1$		ns
$t_{ADAH}^1$	Address/Data 15-0 Hold After ALE Deasserted	$t_{PCLK} - 0.8$		ns
$t_{ALEHZ}^1$	ALE Deasserted to Address/Data 15-0 in High Z	$t_{PCLK} - 0.8$		ns
$t_{RW}$	$\overline{RD}$ Pulse Width	$D - 2$		ns

D = (Data Cycle Duration = the value set by the PPDUR bits (5-1) in the PPCTL register)  $\times t_{PCLK}$

H =  $t_{PCLK}$  (if a hold cycle is specified, else H = 0)

F =  $7 \times t_{PCLK}$  (if FLASH\_MODE is set else F = 0)

<sup>1</sup> On reset, ALE is an active high cycle. However, it can be configured by software to be active low.

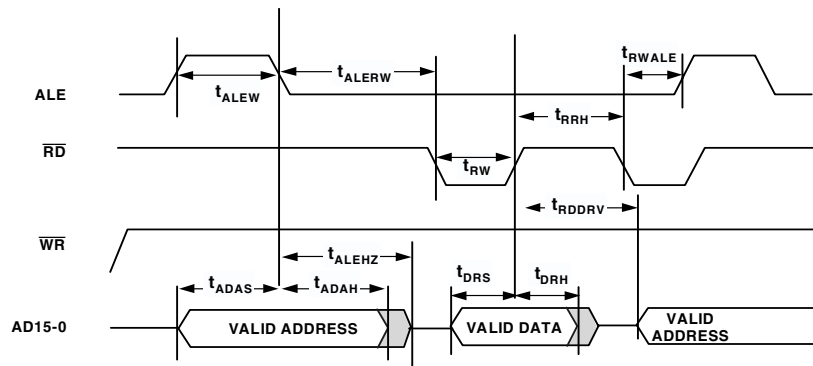

Figure 18. Read Cycle For 16-Bit Memory Timing

**Memory Write—Parallel Port**

Use these specifications for asynchronous interfacing to memories (and memory-mapped peripherals) when the ADSP-21363 is accessing external memory space.

**Table 22. 8-bit Memory Write Cycle**

Parameter		Min	Max	Unit
<i>Switching Characteristics:</i>				
$t_{ALEW}$	ALE Pulse Width	$2 \times t_{PCLK} - 2$		ns
$t_{ADAS}^1$	Address/Data 15–0 Setup Before ALE Deasserted	$t_{PCLK} - 2.5$		ns
$t_{ALERW}$	ALE Deasserted to Read/Write Asserted	$2 \times t_{PCLK} - 2$		ns
$t_{RWALE}$	Write Deasserted to ALE Asserted	$H + 0.5$		ns
$t_{WRH}$	Delay Between $\overline{WR}$ Rising Edge to next $\overline{WR}$ Falling Edge	$F + H + t_{PCLK} - 2$		ns
$t_{ADAH}^1$	Address/Data 15–0 Hold After ALE Deasserted	$t_{PCLK} - 0.5$		ns
$t_{WW}$	$\overline{WR}$ Pulse Width	$D - F - 2$		ns
$t_{ADWL}$	Address/Data 15–8 to $\overline{WR}$ Low	$t_{PCLK} - 1.5$		ns
$t_{ADWH}$	Address/Data 15–8 Hold After $\overline{WR}$ High	$H$		ns
$t_{DWS}$	Address/Data 7–0 Setup Before $\overline{WR}$ High	$D - F + t_{PCLK} - 4$		ns
$t_{DWH}$	Address/Data 7–0 Hold After $\overline{WR}$ High	$H$		ns
$t_{DAWH}$	Address/Data to $\overline{WR}$ High	$D - F + t_{PCLK} - 4$		ns

D = (Data Cycle Duration = the value set by the PPDUR bits (5–1) in the PPCTL register)  $\times t_{PCLK}$

H =  $t_{PCLK}$  (if a hold cycle is specified, else H = 0)

F =  $7 \times t_{PCLK}$  (if FLASH\_MODE is set else F = 0)

<sup>1</sup>On reset, ALE is an active high cycle. However, it can be configured by software to be active low.

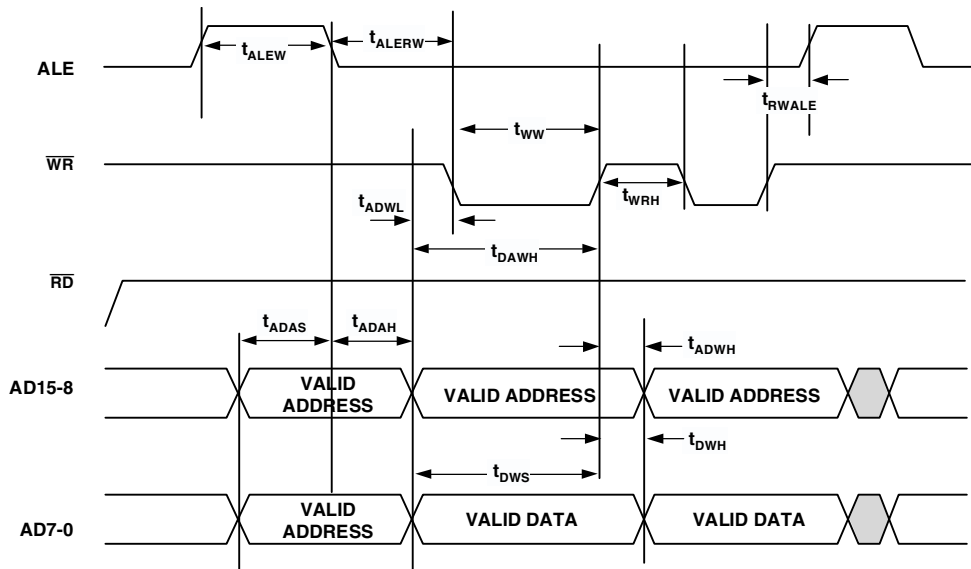

Figure 19. Write Cycle For 8-Bit Memory Timing

Table 23. 16-bit Memory Write Cycle

Parameter	Min	Max	Unit
<i>Switching Characteristics</i>			
$t_{ALEW}$	ALE Pulse Width	$2 \times t_{PCLK} - 2$	ns
$t_{ADAS}^1$	Address/Data 15-0 Setup Before ALE Deasserted	$t_{PCLK} - 2.5$	ns
$t_{ALERW}$	ALE Deasserted to Write Asserted	$2 \times t_{PCLK} - 2$	ns
$t_{RWALE}$	Write Deasserted to ALE Asserted	$H + 0.5$	ns
$t_{WRH}$	Delay Between $\overline{WR}$ Rising Edge to next $\overline{WR}$ Falling Edge	$F + H + t_{PCLK} - 2$	ns
$t_{ADAH}^1$	Address/Data 15-0 Hold After ALE Deasserted	$t_{PCLK} - 0.5$	ns
$t_{WW}$	$\overline{WR}$ Pulse Width	$D - F - 2$	ns
$t_{ALEHZ}^1$	ALE Deasserted to Address/Data 15-0 in High Z	$t_{PCLK} - 1.5$	ns
$t_{DWS}$	Address/Data 15-0 Setup Before $\overline{WR}$ High	$D - F + t_{PCLK} - 4$	ns
$t_{DWH}$	Address/Data 15-0 Hold After $\overline{WR}$ High	H	ns

D = (Data Cycle Duration = the value set by the PPDUR bits (5-1) in the PPCTL register)  $\times t_{PCLK}$

H =  $t_{PCLK}$  (if a hold cycle is specified, else H = 0)

F =  $7 \times t_{PCLK}$  (if FLASH\_MODE is set else F = 0)

<sup>1</sup> On reset, ALE is an active high cycle. However, it can be configured by software to be active low.

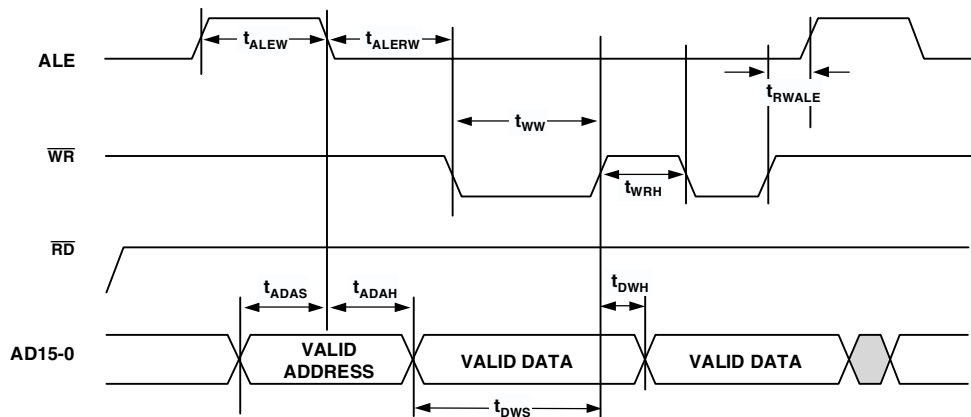

Figure 20. Write Cycle For 16-Bit Memory Timing

## Serial Ports

To determine whether communication is possible between two devices at clock speed  $n$ , the following specifications must be confirmed: 1) frame sync delay and frame sync setup and hold, 2) data delay and data setup and hold, and 3) SCLK width.

Serial port signals (SCLK, FS, DxA,/DxB) are routed to the DAI\_P20–1 pins using the SRU. Therefore, the timing specifications provided below are valid at the DAI\_P20–1 pins.

**Table 24. Serial Ports—External Clock**

Parameter	Min	Max	Unit
<i>Timing Requirements</i>			
$t_{SFSE}^1$ FS Setup Before SCLK (Externally Generated FS in either Transmit or Receive Mode)	2.5		ns
$t_{HFSE}^1$ FS Hold After SCLK (Externally Generated FS in either Transmit or Receive Mode)	2.5		ns
$t_{SDRE}^1$ Receive Data Setup Before Receive SCLK	2.5		ns
$t_{HDRE}^1$ Receive Data Hold After SCLK	2.5		ns
$t_{SCLKW}$ SCLK Width	24		ns
$t_{SCLK}$ SCLK Period	48		ns
<i>Switching Characteristics</i>			
$t_{DFSE}^2$ FS Delay After SCLK (Internally Generated FS in either Transmit or Receive Mode)		7	ns
$t_{HOFSE}^2$ FS Hold After SCLK (Internally Generated FS in either Transmit or Receive Mode)	2		ns
$t_{DDTE}^2$ Transmit Data Delay After Transmit SCLK		7	ns
$t_{HDTE}^2$ Transmit Data Hold After Transmit SCLK	2		ns

<sup>1</sup>Referenced to sample edge.

<sup>2</sup>Referenced to drive edge.

**Table 25. Serial Ports—Internal Clock**

Parameter	Min	Max	Unit
<i>Timing Requirements</i>			
$t_{SFSI}^1$ FS Setup Before SCLK (Externally Generated FS in either Transmit or Receive Mode)	7		ns
$t_{HFSI}^1$ FS Hold After SCLK (Externally Generated FS in either Transmit or Receive Mode)	2.5		ns
$t_{SDRI}^1$ Receive Data Setup Before SCLK	7		ns
$t_{HDRI}^1$ Receive Data Hold After SCLK	2.5		ns
<i>Switching Characteristics</i>			
$t_{DFSI}^2$ FS Delay After SCLK (Internally Generated FS in Transmit Mode)		3	ns
$t_{HOFSI}^2$ FS Hold After SCLK (Internally Generated FS in Transmit Mode)	-1.0		ns
$t_{DFSI}^2$ FS Delay After SCLK (Internally Generated FS in Receive Mode)		3	ns
$t_{HOFSI}^2$ FS Hold After SCLK (Internally Generated FS in Receive Mode)	-1.0		ns
$t_{DDTI}^2$ Transmit Data Delay After SCLK		3	ns
$t_{HDTI}^2$ Transmit Data Hold After SCLK	-1.0		ns
$t_{SCLKIW}$ Transmit or Receive SCLK Width	$0.5t_{SCLK} - 2$	$0.5t_{SCLK} + 2$	ns

<sup>1</sup>Referenced to the sample edge.

<sup>2</sup>Referenced to drive edge.

Table 26. Serial Ports—Enable and Three-State

Parameter	Min	Max	Unit
<i>Switching Characteristics</i>			
$t_{DDTEN}^1$ Data Enable from External Transmit SCLK	2		ns
$t_{DDTTE}^1$ Data Disable from External Transmit SCLK		7	ns
$t_{DDTIN}^1$ Data Enable from Internal Transmit SCLK	-1		ns

<sup>1</sup>Referenced to drive edge.

Table 27. Serial Ports—External Late Frame Sync

Parameter	Min	Max	Unit
<i>Switching Characteristics</i>			
$t_{DDTLFSE}^1$ Data Delay from Late External Transmit FS or External Receive FS with MCE = 1, MFD = 0		7	ns
$t_{DDTENFS}^1$ Data Enable for MCE = 1, MFD = 0	0.5		ns

<sup>1</sup>The  $t_{DDTLFSE}$  and  $t_{DDTENFS}$  parameters apply to Left-justified Sample Pair as well as DSP serial mode, and MCE = 1, MFD = 0.

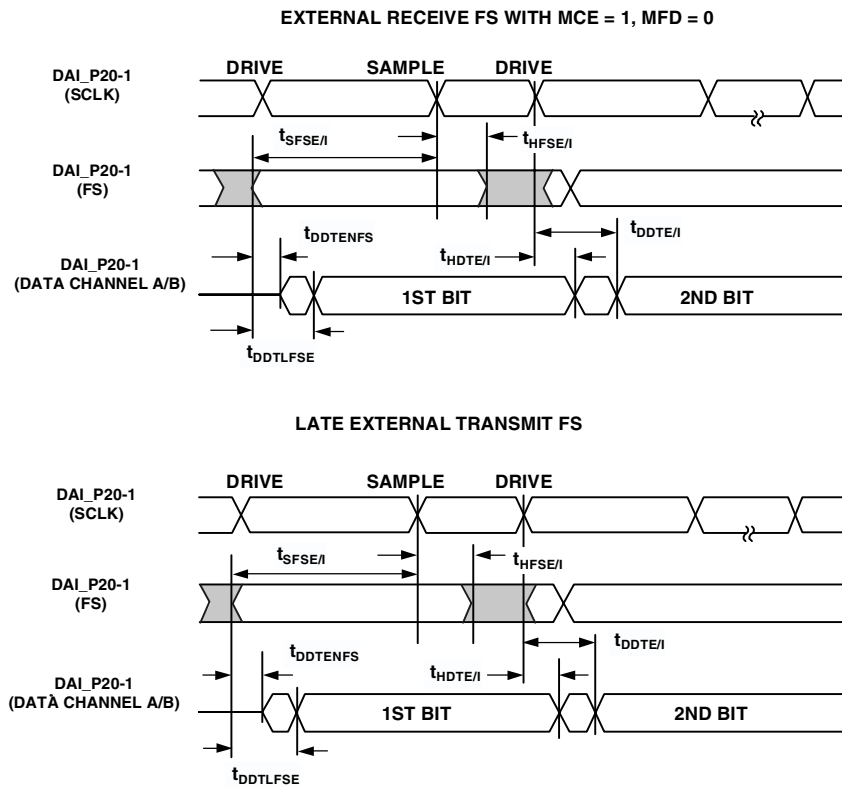

NOTE  
SERIAL PORT SIGNALS (SCLK, FS, DATA CHANNEL A/B) ARE ROUTED TO THE DAI\_P20-1 PINS USING THE SRU. THE TIMING SPECIFICATIONS PROVIDED HERE ARE VALID AT THE DAI\_P20-1 PINS.

Figure 21. External Late Frame Sync<sup>1</sup>

<sup>1</sup>This figure reflects changes made to support Left-justified Sample Pair mode.

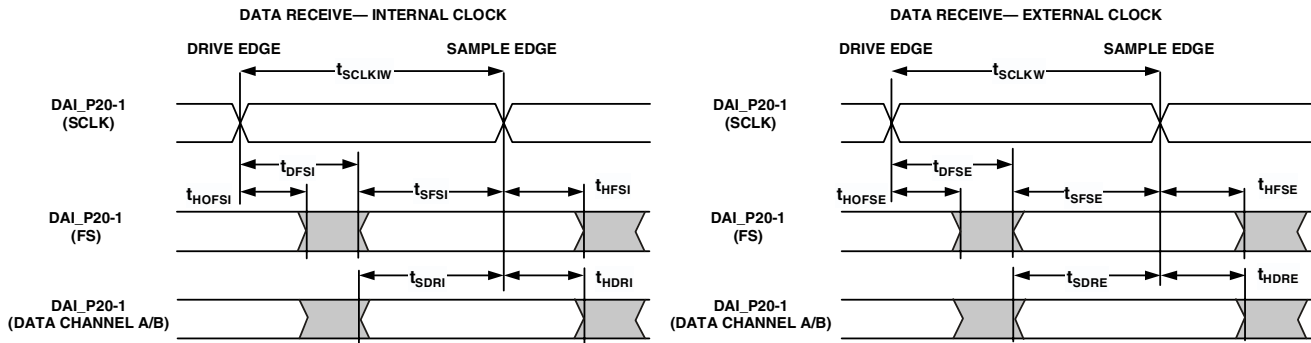

NOTE: EITHER THE RISING EDGE OR FALLING EDGE OF SCLK (EXTERNAL), SCLK (INTERNAL) CAN BE USED AS THE ACTIVE SAMPLING EDGE.

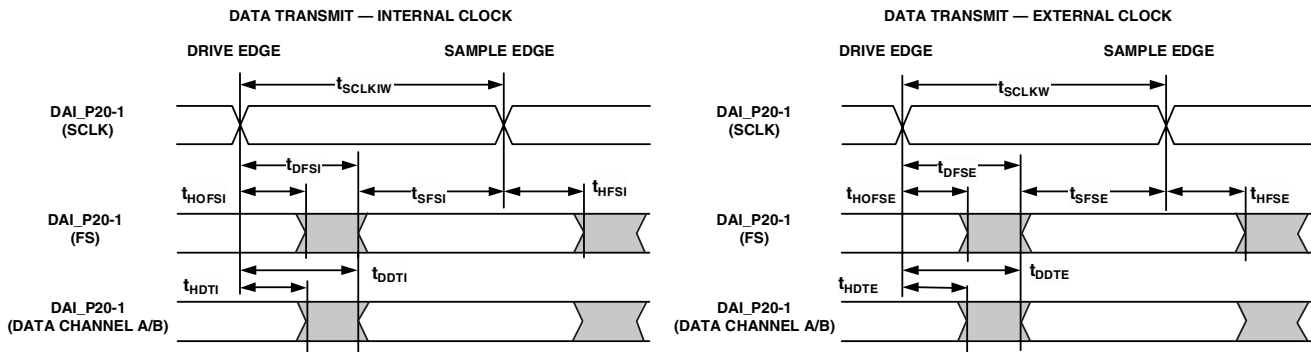

NOTE: EITHER THE RISING EDGE OR FALLING EDGE OF SCLK (EXTERNAL), SCLK (INTERNAL) CAN BE USED AS THE ACTIVE SAMPLING EDGE.

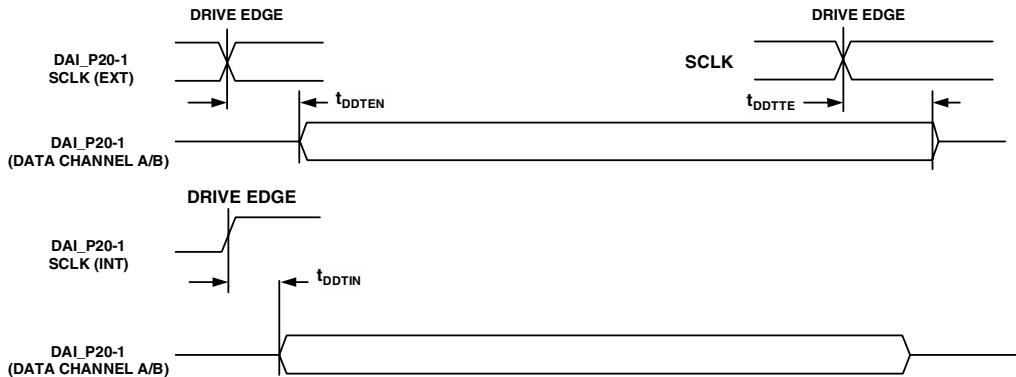

Figure 22. Serial Ports

**Input Data Port (IDP)**

The timing requirements for the IDP are given in Table 28. IDP Signals (SCLK, FS, SDATA) are routed to the DAI\_P20-1 pins using the SRU. Therefore, the timing specifications provided below are valid at the DAI\_P20-1 pins.

**Table 28. IDP**

Parameter		Min	Max	Unit
<i>Timing Requirements</i>				
$t_{SIFS}^1$	FS Setup Before SCLK Rising Edge	2.5		ns
$t_{SIHFS}^1$	FS Hold After SCLK Rising Edge	2.5		ns
$t_{SISD}^1$	SData Setup Before SCLK Rising Edge	2.5		ns
$t_{SIHD}^1$	SData Hold After SCLK Rising Edge	2.5		ns
$t_{DPCLKW}$	Clock Width	9		ns
$t_{DPCLK}$	Clock Period	24		ns

<sup>1</sup> DATA, SCLK, FS can come from any of the DAI pins. SCLK and FS can also come via PCG or SPORTs. PCG's input can be either CLKIN or any of the DAI pins.

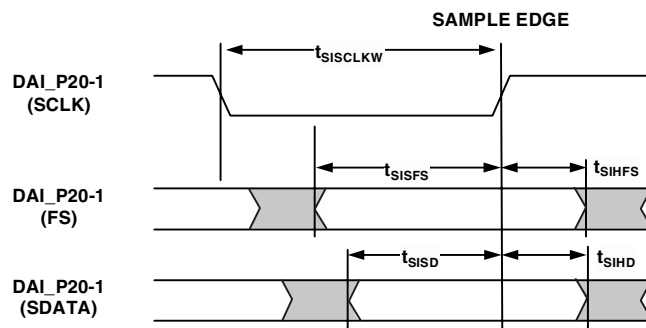

Figure 23. IDP Master Timing

## Parallel Data Acquisition Port (PDAP)

The timing requirements for the PDAP are provided in [Table 29](#). PDAP is the parallel mode operation of channel 0 of the IDP. For details on the operation of the IDP, see the IDP chapter of the *ADSP-2136x SHARC Processor Hardware Refer-*

*ence*. Note that the most significant 16 bits of external PDAP data can be provided through either the parallel port AD15-0 or the DAI\_P20-5 pins. The remaining 4 bits can only be sourced through DAI\_P4-1. The timing below is valid at the DAI\_P20-1 pins or at the AD15-0 pins.

**Table 29. Parallel Data Acquisition Port (PDAP)**

Parameter	Min	Max	Unit
<i>Timing Requirements</i>			
$t_{SPCLKEN}^1$ PDAP_CLKEN Setup Before PDAP_CLK Sample Edge	2.5		ns
$t_{HPCLKEN}^1$ PDAP_CLKEN Hold After PDAP_CLK Sample Edge	2.5		ns
$t_{PDS}^1$ PDAP_DAT Setup Before SCLK PDAP_CLK Sample Edge	2.5		ns
$t_{PDHD}^1$ PDAP_DAT Hold After SCLK PDAP_CLK Sample Edge	2.5		ns
$t_{PDCLKW}$ Clock Width	7		ns
$t_{PDCLK}$ Clock Period	24		ns
<i>Switching Characteristics</i>			
$t_{PDHLDD}$ Delay of PDAP Strobe After Last PDAP_CLK Capture Edge for a Word	$2 \times t_{CCLK}$		ns
$t_{PDSTRB}$ PDAP Strobe Pulse Width	$1 \times t_{CCLK} - 1$		ns

<sup>1</sup> Source pins of DATA are ADDR7-0, DATA7-0, or DAI pins. Source pins for SCLK and FS are: 1) DAI pins, 2) CLKIN through PCG, or 3) DAI pins through PCG.

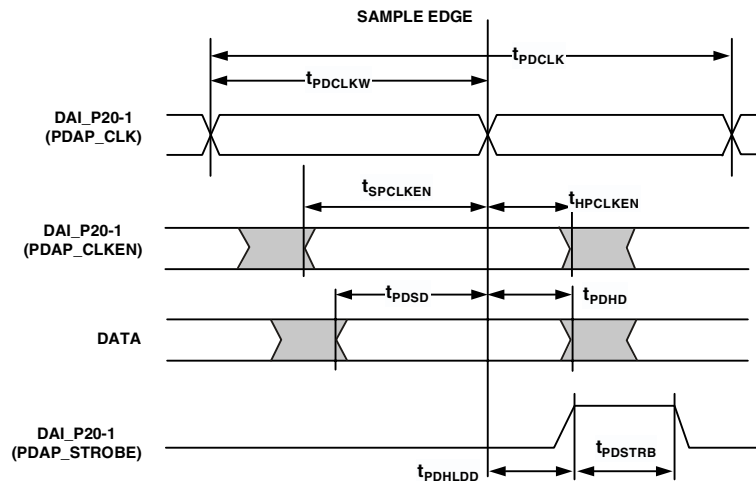

Figure 24. PDAP Timing

**SPI Interface—Master**

The ADSP-21363 contains two SPI ports. The primary has dedicated pins and the secondary is available through the DAI. The timing provided in Table 30 and Table 31 applies to both.

**Table 30. SPI Interface Protocol — Master Switching and Timing Specifications**

Parameter		Min	Max	Unit
<i>Timing Requirements</i>				
$t_{SSPIDM}$	Data Input Valid to SPICLK edge (Data Input Set-up Time)	8		ns
$t_{HSPIDM}$	SPICLK Last Sampling Edge to Data Input Not Valid	2		ns
<i>Switching Characteristics</i>				
$t_{SPICLKM}$	Serial Clock Cycle	$8 \times t_{PCLK}$		ns
$t_{SPICHM}$	Serial Clock High Period	$4 \times t_{PCLK}$		ns
$t_{SPICLM}$	Serial Clock Low Period	$4 \times t_{PCLK} - 2$		ns
$t_{DDSPIDM}$	SPICLK Edge to Data Out Valid (Data Out Delay Time)		0	
$t_{HDSPIDM}$	SPICLK Edge to Data Out Not Valid (Data Out Hold Time)	2		ns
$t_{SDSCIM}$	FLAG3-0IN (SPI Device Select) Low to First SPICLK Edge	$4 \times t_{PCLK} - 2$		ns
$t_{HDSM}$	Last SPICLK edge to FLAG3-0IN high	$4 \times t_{PCLK} - 1$		ns
$t_{SPITDM}$	Sequential Transfer Delay	$4 \times t_{PCLK} - 1$		ns

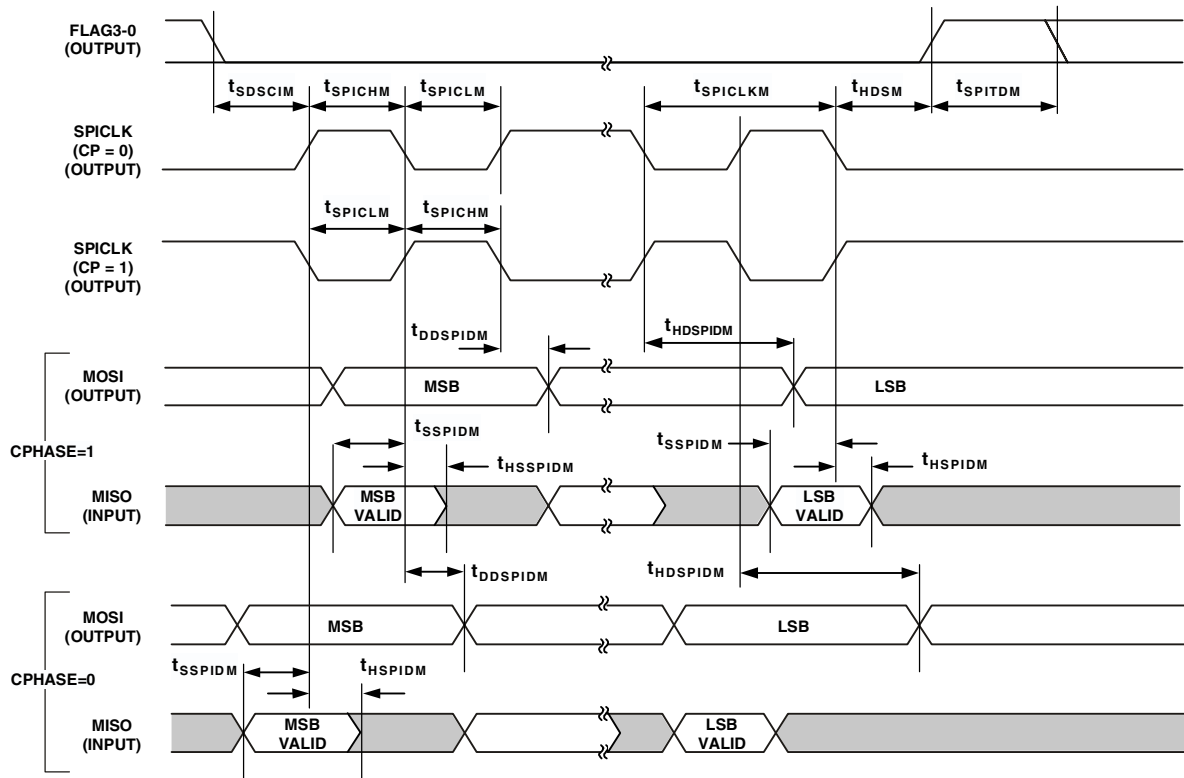

Figure 25. SPI Master Timing

SPI Interface—Slave

Table 31. SPI Interface Protocol —Slave Switching and Timing Specifications

Parameter		Min	Max	Unit
<i>Timing Requirements</i>				
$t_{SPICLK}$	Serial Clock Cycle	$4 \times t_{PCLK}$		ns
$t_{SPICHS}$	Serial Clock High Period	$2 \times t_{PCLK}$		ns
$t_{SPICLS}$	Serial Clock Low Period	$2 \times t_{PCLK} - 2$		ns
$t_{SDSCO}$	$\overline{SPIDS}$ Assertion to First SPICLK Edge			ns
	CPHASE = 0	$2 \times t_{PCLK}$		
	CPHASE = 1	$2 \times t_{PCLK}$		
$t_{HDS}$	Last SPICLK Edge to $\overline{SPIDS}$ Not Asserted, CPHASE = 0	$2 \times t_{PCLK}$		ns
$t_{SSPIDS}$	Data Input Valid to SPICLK edge (Data Input Set-up Time)	2		ns
$t_{HSPIDS}$	SPICLK Last Sampling Edge to Data Input Not Valid	2		ns
$t_{SDPPW}$	$\overline{SPIDS}$ Deassertion Pulse Width (CPHASE=0)	$2 \times t_{PCLK}$		ns
<i>Switching Characteristics</i>				
$t_{DSOE}$	$\overline{SPIDS}$ Assertion to Data Out Active	0	4	ns
$t_{DSDHI}$	$\overline{SPIDS}$ Deassertion to Data High Impedance	0	4	ns
$t_{DDSPIDS}$	SPICLK Edge to Data Out Valid (Data Out Delay Time)		9.4	ns
$t_{HDSPIDS}$	SPICLK Edge to Data Out Not Valid (Data Out Hold Time)	$2 \times t_{PCLK}$		ns
$t_{DSOV}$	$\overline{SPIDS}$ Assertion to Data Out Valid (CPHASE=0)		$5 \times t_{PCLK}$	ns

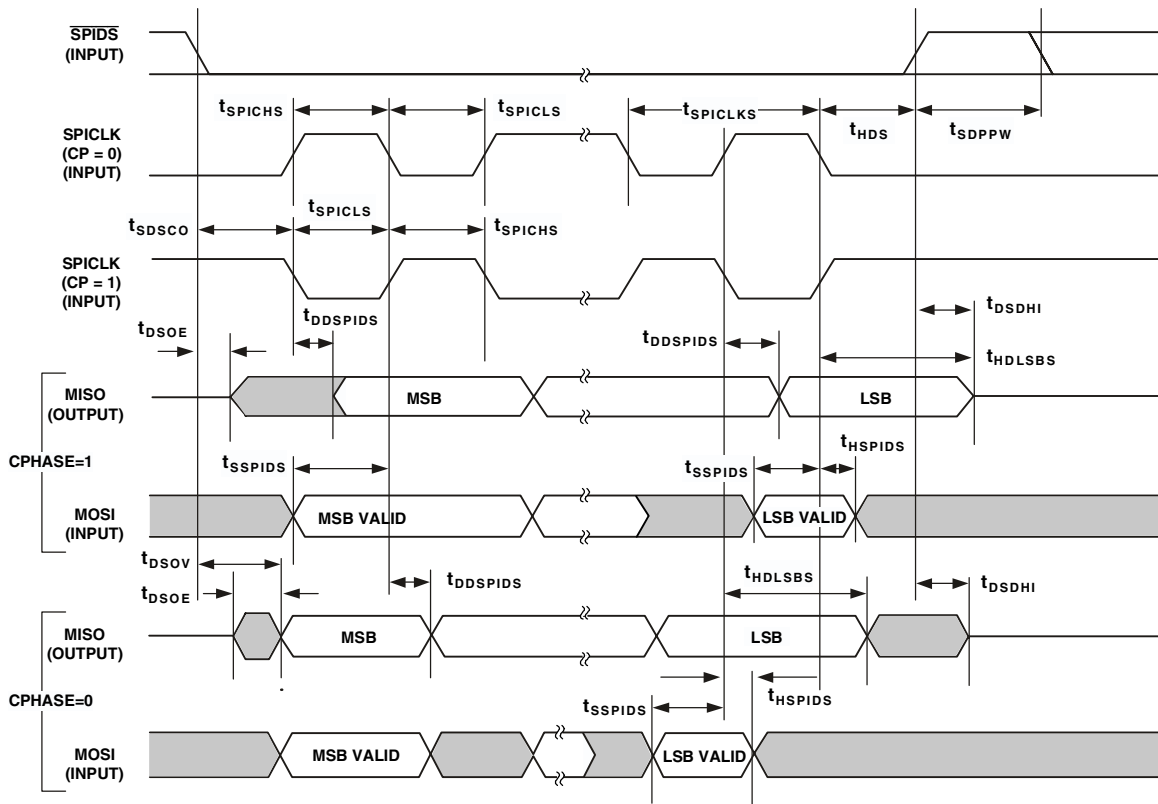

Figure 26. SPI Slave Timing

JTAG Test Access Port and Emulation

Table 32. JTAG Test Access Port and Emulation

Parameter		Min	Max	Unit
<i>Timing Requirements</i>				
$t_{TCK}$	TCK Period	$t_{CK}$		ns
$t_{STAP}$	TDI, TMS Setup Before TCK High	5		ns
$t_{HTAP}$	TDI, TMS Hold After TCK High	6		ns
$t_{SSYS}^1$	System Inputs Setup Before TCK Low	7		ns
$t_{HSYS}^1$	System Inputs Hold After TCK Low	18		ns
$t_{TRSTW}$	$\overline{TRST}$ Pulse Width	$4t_{CK}$		ns
<i>Switching Characteristics</i>				
$t_{DTDO}$	TDO Delay From TCK Low		7	ns
$t_{DSYS}^2$	System Outputs Delay After TCK Low		10	ns

<sup>1</sup>System Inputs = AD15-0,  $\overline{SPIDS}$ , CLKCFG1-0,  $\overline{RESET}$ , BOOTCFG1-0, MISO, MOSI, SPICLK, DAI\_Px, FLAG3-0.

<sup>2</sup>System Outputs = MISO, MOSI, SPICLK, DAI\_Px, AD15-0,  $\overline{RD}$ ,  $\overline{WR}$ , FLAG3-0, CLKOUT,  $\overline{EMU}$ , ALE.

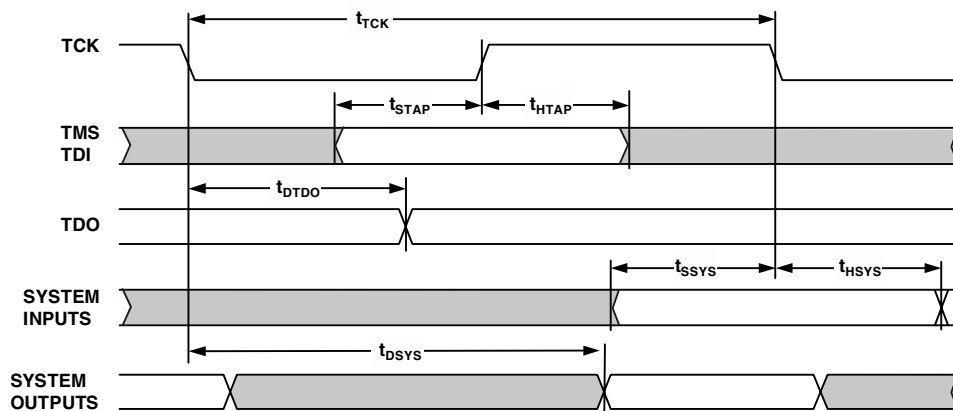

Figure 27. IEEE 1149.1 JTAG Test Access Port

## OUTPUT DRIVE CURRENTS

Figure 28 shows typical I-V characteristics for the output drivers of the ADSP-21363. The curves represent the current drive capability of the output drivers as a function of output voltage.

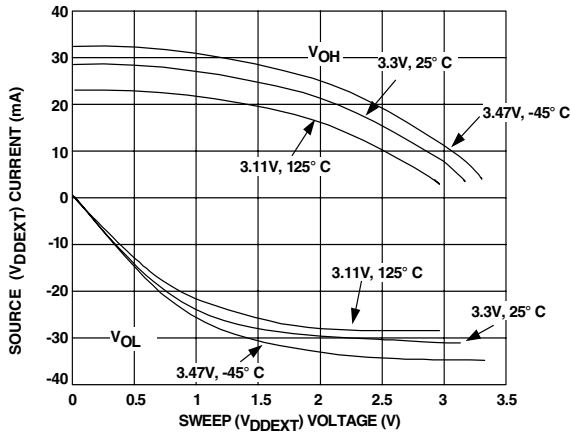

Figure 28. ADSP-21363 Typical Drive

## TEST CONDITIONS

The ac signal specifications (timing parameters) appear Table 12 on Page 19 through Table 32 on Page 35. These include output disable time, output enable time, and capacitive loading. The timing specifications for the SHARC apply for the voltage reference levels in Figure 29.

Timing is measured on signals when they cross the 1.5 V level as described in Figure 30 on Page 36. All delays (in nanoseconds) are measured between the point that the first signal reaches 1.5 V and the point that the second signal reaches 1.5 V.

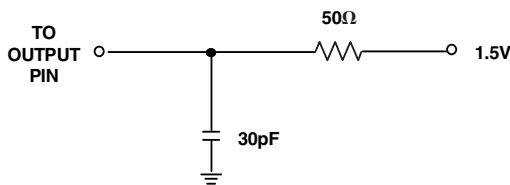

Figure 29. Equivalent Device Loading for AC Measurements (Includes All Fixtures)



Figure 30. Voltage Reference Levels for AC Measurements

## CAPACITIVE LOADING

Output delays and holds are based on standard capacitive loads: 30 pF on all pins (see Figure 29). Figure 33 shows graphically how output delays and holds vary with load capacitance. The graphs of Figure 31, Figure 32, and Figure 33 may not be linear outside the ranges shown for Typical Output Delay vs. Load Capacitance and Typical Output Rise Time (20%-80%, V=Min) vs. Load Capacitance.

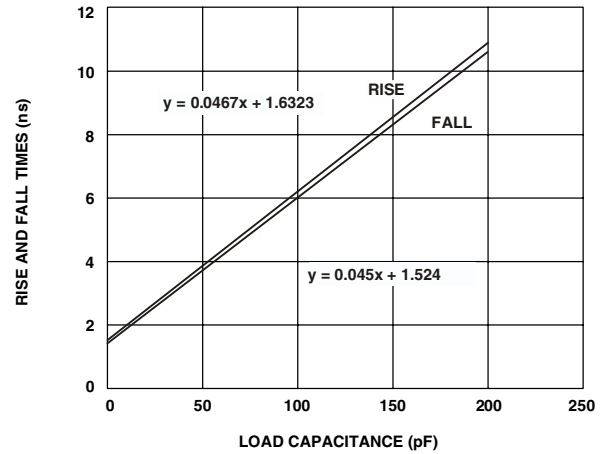

Figure 31. Typical Output Rise/Fall Time (20%-80%,  $V_{DDEXT} = Max$ )

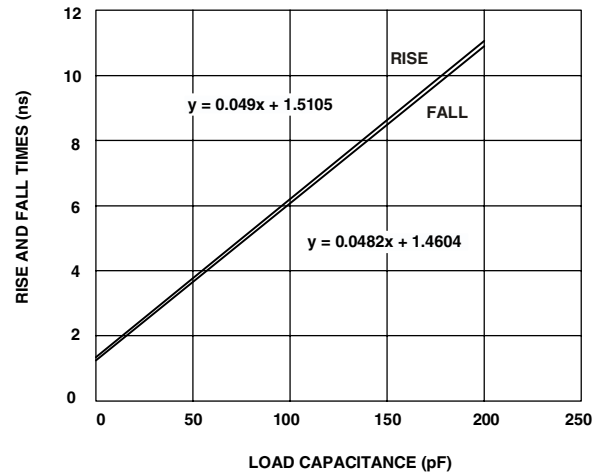

Figure 32. Typical Output Rise/Fall Time (20%-80%,  $V_{DDEXT} = Min$ )

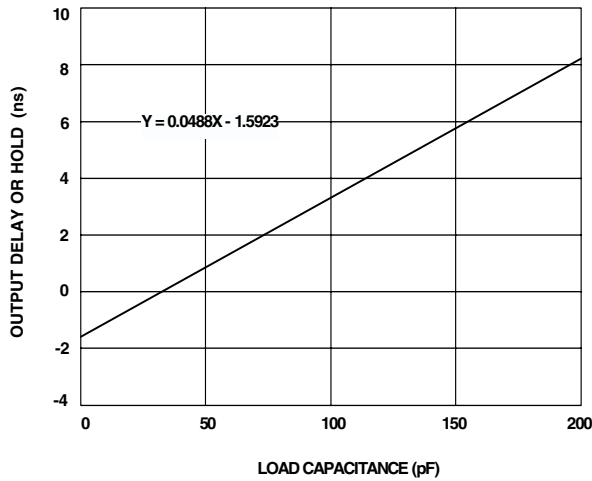

Figure 33. Typical Output Delay or Hold vs. Load Capacitance (at Ambient Temperature)

**THERMAL CHARACTERISTICS**

The ADSP-21363 processor is rated for performance to a maximum junction temperature of 125°C.

Table 33 through Table 36 airflow measurements comply with JEDEC standards JESD51-2 and JESD51-6 and the junction-to-board measurement complies with JESD51-8. Test board and thermal via design comply with JEDEC standards JESD51-9 (Mini-BGA) and JESD51-5 (Integrated Heatsink LQFP). The junction-to-case measurement complies with MIL-STD-883. All measurements use a 2S2P JEDEC test board.

Industrial applications using the Mini-BGA package require thermal vias, to an embedded ground plane, in the PCB. Refer to JEDEC Standard JESD51-9 for printed circuit board thermal ball land and thermal via design information. Industrial applications using the LQFP package require thermal trace squares and thermal vias, to an embedded ground plane, in the PCB. The bottom side heat slug must be soldered to the thermal trace squares. Refer to JEDEC Standard JESD51-5 for more information.

To determine the Junction Temperature of the device while on the application PCB, use:

$$T_J = T_{CASE} + (\Psi_{JT} \times P_D)$$

where:

$T_J$  = Junction temperature (°C)

$T_{CASE}$  = Case temperature (°C) measured at the top center of the package

$\Psi_{JT}$  = Junction-to-Top (of package) characterization parameter is the Typical value from Table 33 through Table 36.

$P_D$  = Power dissipation (see EE Note #TBD)

Values of  $\theta_{JA}$  are provided for package comparison and PCB design considerations.  $\theta_{JA}$  can be used for a first order approximation of  $T_J$  by the equation:

$$T_J = T_A + (\theta_{JA} \times P_D)$$

where:

$T_A$  = Ambient Temperature (°C)

Values of  $\theta_{JC}$  are provided for package comparison and PCB design considerations when an external heatsink is required.

Values of  $\theta_{JB}$  are provided for package comparison and PCB design considerations. Note that the thermal characteristics values provided in tables 33 through 36 are modeled values.

Table 33. Thermal Characteristics for 136 Ball Mini-BGA (No thermal vias in PCB)

Parameter	Condition	Typical	Unit
$\theta_{JA}$	Airflow = 0 m/s	25.20	°C/W
$\theta_{JMA}$	Airflow = 1 m/s	21.70	°C/W
$\theta_{JMA}$	Airflow = 2 m/s	20.80	°C/W
$\theta_{JC}$		5.00	°C/W
$\Psi_{JT}$	Airflow = 0 m/s	0.140	°C/W
$\Psi_{JMT}$	Airflow = 1 m/s	0.330	°C/W
$\Psi_{JMT}$	Airflow = 2 m/s	0.410	°C/W

Table 34. Thermal Characteristics for 136 Ball Mini-BGA (Thermal vias in PCB)

Parameter	Condition	Typical	Unit
$\theta_{JA}$	Airflow = 0 m/s	22.50	°C/W
$\theta_{JMA}$	Airflow = 1 m/s	19.30	°C/W
$\theta_{JMA}$	Airflow = 2 m/s	18.40	°C/W
$\theta_{JC}$		5.00	°C/W
$\Psi_{JT}$	Airflow = 0 m/s	0.130	°C/W
$\Psi_{JMT}$	Airflow = 1 m/s	0.300	°C/W
$\Psi_{JMT}$	Airflow = 2 m/s	0.360	°C/W

Table 35. Thermal Characteristics for 144-Lead Integrated Heatsink (INT-HS) LQFP (With heat slug not soldered to PCB)

Parameter	Condition	Typical	Unit
$\theta_{JA}$	Airflow = 0 m/s	26.08	°C/W
$\theta_{JMA}$	Airflow = 1 m/s	24.59	°C/W
$\theta_{JMA}$	Airflow = 2 m/s	23.77	°C/W
$\theta_{JC}$		6.83	°C/W
$\Psi_{JT}$	Airflow = 0 m/s	0.236	°C/W
$\Psi_{JMT}$	Airflow = 1 m/s	0.427	°C/W
$\Psi_{JMT}$	Airflow = 2 m/s	0.441	°C/W

**Table 36. Thermal Characteristics for 144-Lead Integrated Heatsink (INT-HS) LQFP (With heat slug soldered to PCB)<sup>1</sup>**

Parameter	Condition	Typical	Unit
$\theta_{JA}$	Airflow = 0 m/s	16.50	°C/W
$\theta_{JMA}$	Airflow = 1 m/s	15.14	°C/W
$\theta_{JMA}$	Airflow = 2 m/s	14.35	°C/W
$\theta_{JC}$		6.83	°C/W
$\Psi_{JT}$	Airflow = 0 m/s	0.129	°C/W
$\Psi_{JMT}$	Airflow = 1 m/s	0.255	°C/W
$\Psi_{JMT}$	Airflow = 2 m/s	0.261	°C/W

<sup>1</sup>The thermal characteristics values provided in these tables are modeled values.

### 136-BALL BGA PIN CONFIGURATIONS

Table 37. 136-Ball Mini-BGA Pin Assignments

Pin Name	BGA Pin#	Pin Name	BGA Pin#	Pin Name	BGA Pin#	Pin Name	BGA Pin#
CLKCFG0	A01	CLKCFG1	B01	BOOTCFG1	C01	V <sub>DDINT</sub>	D01
XTAL	A02	GND	B02	BOOTCFG0	C02	GND	D02
TMS	A03	V <sub>DDEXT</sub>	B03	GND	C03	GND	D04
TCK	A04	CLKIN	B04	GND	C12	GND	D05
TDI	A05	TRST	B05	GND	C13	GND	D06
CLKOUT	A06	A <sub>VSS</sub>	B06	V <sub>DDINT</sub>	C14	GND	D09
TDO	A07	A <sub>VDD</sub>	B07			GND	D10
EMU	A08	V <sub>DDEXT</sub>	B08			GND	D11
MOSI	A09	SPICLK	B09			GND	D13
MISO	A10	RESET	B10			V <sub>DDINT</sub>	D14
SPIDS	A11	V <sub>DDINT</sub>	B11				
V <sub>DDINT</sub>	A12	GND	B12				
GND	A13	GND	B13				
GND	A14	GND	B14				
V <sub>DDINT</sub>	E01	FLAG1	F01	AD7	G01	AD6	H01
GND	E02	FLAG0	F02	V <sub>DDINT</sub>	G02	V <sub>DDEXT</sub>	H02
GND	E04	GND	F04	V <sub>DDEXT</sub>	G13	DAI_P18 (SD5B)	H13
GND	E05	GND	F05	DAI_P19 (SCLK45)	G14	DAI_P17 (SD5A)	H14
GND	E06	GND	F06				
GND	E09	GND	F09				
GND	E10	GND	F10				
GND	E11	GND	F11				
GND	E13	FLAG2	F13				
FLAG3	E14	DAI_P20 (SFS45)	F14				

Table 37. 136-Ball Mini-BGA Pin Assignments (Continued)

Pin Name	BGA Pin#	Pin Name	BGA Pin#	Pin Name	BGA Pin#	Pin Name	BGA Pin#
AD5	J01	AD3	K01	AD2	L01	AD0	M01
AD4	J02	V <sub>DDINT</sub>	K02	AD1	L02	$\overline{WR}$	M02
GND	J04	GND	K04	GND	L04	GND	M03
GND	J05	GND	K05	GND	L05	GND	M12
GND	J06	GND	K06	GND	L06	DAI_P12 (SD3B)	M13
GND	J09	GND	K09	GND	L09	DAI_P13 (SCLK23)	M14
GND	J10	GND	K10	GND	L10		
GND	J11	GND	K11	GND	L11		
V <sub>DDINT</sub>	J13	GND	K13	GND	L13		
DAI_P16 (SD4B)	J14	DAI_P15 (SD4A)	K14	DAI_P14 (SFS23)	L14		
AD15	N01	AD14	P01				
ALE	N02	AD13	P02				
$\overline{RD}$	N03	AD12	P03				
V <sub>DDINT</sub>	N04	AD11	P04				
V <sub>DDEXT</sub>	N05	AD10	P05				
AD8	N06	AD9	P06				
V <sub>DDINT</sub>	N07	DAI_P1 (SD0A)	P07				
DAI_P2 (SD0B)	N08	DAI_P3 (SCLK0)	P08				
V <sub>DDEXT</sub>	N09	DAI_P5 (SD1A)	P09				
DAI_P4 (SFS0)	N10	DAI_P6 (SD1B)	P10				
V <sub>DDINT</sub>	N11	DAI_P7 (SCLK1)	P11				
V <sub>DDINT</sub>	N12	DAI_P8 (SFS1)	P12				
GND	N13	DAI_P9 (SD2A)	P13				
DAI_P10 (SD2B)	N14	DAI_P11 (SD3A)	P14				

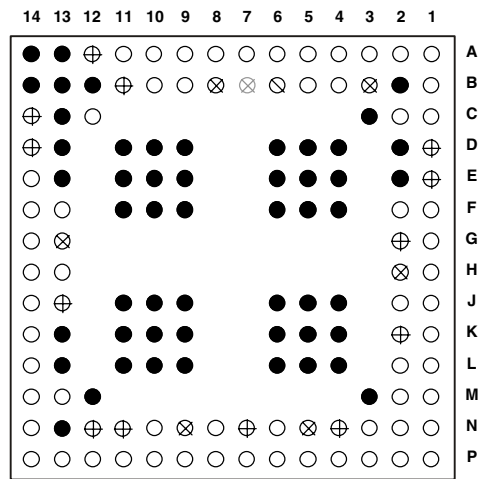

KEY

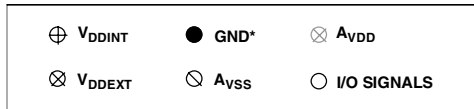

\*USE THE CENTER BLOCK OF GROUND PINS TO PROVIDE THERMAL PATHWAYS TO YOUR PRINTED CIRCUIT BOARD'S GROUND PLANE.

Figure 34. 136-Ball Mini-BGA Pin Assignments (Bottom View, Summary)

## 144-LEAD LQFP PIN CONFIGURATIONS

The following table shows the ADSP-21363's pin names and their default function after reset (in parentheses).

Table 38. 144-Lead LQFP Pin Assignments

Pin Name	LQFP Pin No.	Pin Name	LQFP Pin No.	Pin Name	LQFP Pin No.	Pin Name	LQFP Pin No.
V <sub>DDINT</sub>	1	V <sub>DDINT</sub>	37	V <sub>DDEXT</sub>	73	GND	109
CLKCFG0	2	GND	38	GND	74	V <sub>DDINT</sub>	110
CLKCFG1	3	$\overline{\text{RD}}$	39	V <sub>DDINT</sub>	75	GND	111
BOOTCFG0	4	ALE	40	GND	76	V <sub>DDINT</sub>	112
BOOTCFG1	5	AD15	41	DAI_P10 (SD2B)	77	GND	113
GND	6	AD14	42	DAI_P11 (SD3A)	78	V <sub>DDINT</sub>	114
V <sub>DDEXT</sub>	7	AD13	43	DAI_P12 (SD3B)	79	GND	115
GND	8	GND	44	DAI_P13 (SCLK23)	80	V <sub>DDEXT</sub>	116
V <sub>DDINT</sub>	9	V <sub>DDEXT</sub>	45	DAI_P14 (SFS23)	81	GND	117
GND	10	AD12	46	DAI_P15 (SD4A)	82	V <sub>DDINT</sub>	118
V <sub>DDINT</sub>	11	V <sub>DDINT</sub>	47	V <sub>DDINT</sub>	83	GND	119
GND	12	GND	48	GND	84	V <sub>DDINT</sub>	120
V <sub>DDINT</sub>	13	AD11	49	GND	85	$\overline{\text{RESET}}$	121
GND	14	AD10	50	DAI_P16 (SD4B)	86	$\overline{\text{SPIDS}}$	122
FLAG0	15	AD9	51	DAI_P17 (SD5A)	87	GND	123
FLAG1	16	AD8	52	DAI_P18 (SD5B)	88	V <sub>DDINT</sub>	124
AD7	17	DAI_P1 (SD0A)	53	DAI_P19 (SCLK45)	89	SPICK	125
GND	18	V <sub>DDINT</sub>	54	V <sub>DDINT</sub>	90	MISO	126
V <sub>DDINT</sub>	19	GND	55	GND	91	MOSI	127
GND	20	DAI_P2 (SD0B)	56	GND	92	GND	128
V <sub>DDEXT</sub>	21	DAI_P3 (SCLK0)	57	V <sub>DDEXT</sub>	93	V <sub>DDINT</sub>	129
GND	22	GND	58	DAI_P20 (SFS45)	94	V <sub>DDEXT</sub>	130
V <sub>DDINT</sub>	23	V <sub>DDEXT</sub>	59	GND	95	A <sub>VDD</sub>	131
AD6	24	V <sub>DDINT</sub>	60	V <sub>DDINT</sub>	96	A <sub>VSS</sub>	132
AD5	25	GND	61	FLAG2	97	GND	133
AD4	26	DAI_P4 (SFS0)	62	FLAG3	98	CLKOUT	134
V <sub>DDINT</sub>	27	DAI_P5 (SD1A)	63	V <sub>DDINT</sub>	99	EMU	135
GND	28	DAI_P6 (SD1B)	64	GND	100	TDO	136
AD3	29	DAI_P7 (SCLK1)	65	V <sub>DDINT</sub>	101	TDI	137
AD2	30	V <sub>DDINT</sub>	66	GND	102	TRST	138
V <sub>DDEXT</sub>	31	GND	67	V <sub>DDINT</sub>	103	TCK	139
GND	32	V <sub>DDINT</sub>	68	GND	104	TMS	140
AD1	33	GND	69	V <sub>DDINT</sub>	105	GND	141
AD0	34	DAI_P8 (SFS1)	70	GND	106	CLKIN	142
$\overline{\text{WR}}$	35	DAI_P9 (SD2A)	71	V <sub>DDINT</sub>	107	XTAL	143
V <sub>DDINT</sub>	36	V <sub>DDINT</sub>	72	V <sub>DDINT</sub>	108	V <sub>DDEXT</sub>	144

### PACKAGE DIMENSIONS

The ADSP-21363 is available in a 136-ball Mini-BGA package and a 144-lead integrated heatsink LQFP package.

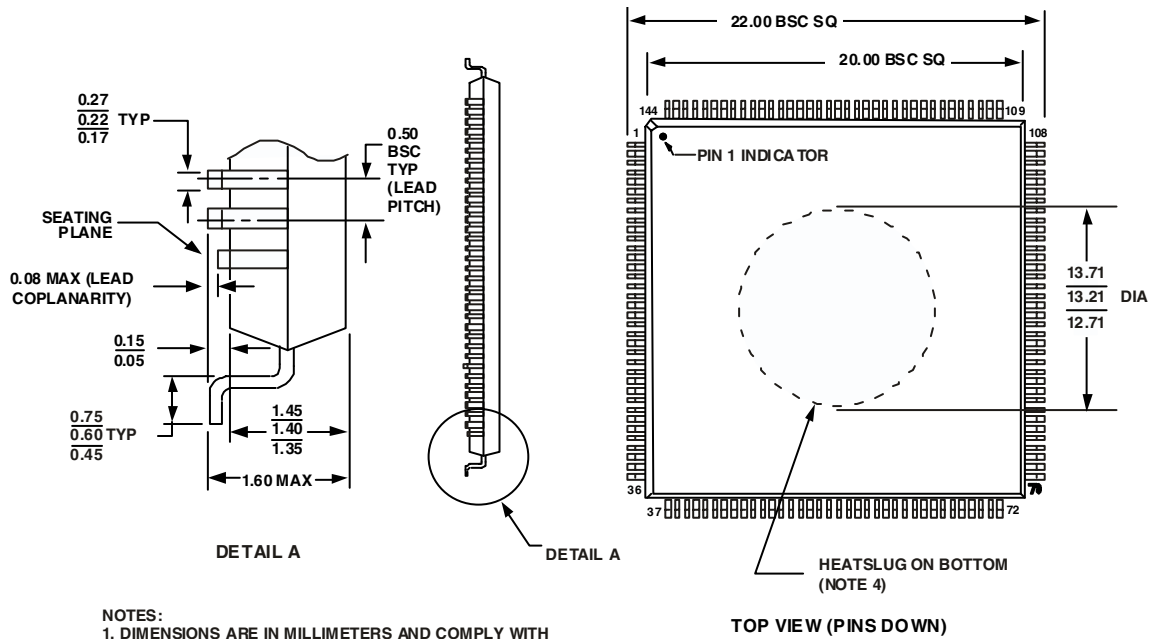

Figure 35. 144-Lead Integrated Heatsink LQFP (SQ-144-3)

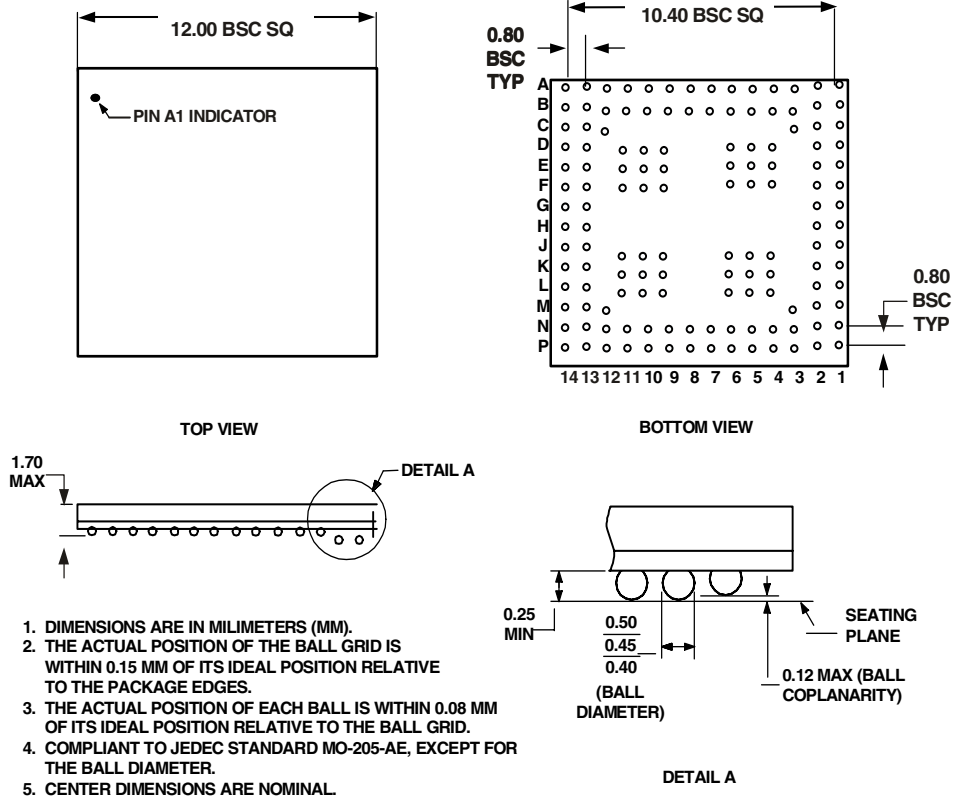

Figure 36. 136-Ball Mini-BGA (BC-136-2)

ORDERING GUIDE

Part Number <sup>1, 2, 3</sup>	Ambient Temperature Range °C	Instruction Rate	On-Chip SRAM	ROM	Operating Voltage Internal/External Volts	Package
ADSP-21363SKBCZENG	0 to 70	333MHz	3M bit	4M bit	1.2/3.3	136 Mini-BGA Pb-free
ADSP-21363SKBC-ENG	0 to 70	333MHz	3M bit	4M bit	1.2/3.3	136 Mini-BGA
ADSP-21363SKSQZENG	0 to 70	333MHz	3M bit	4M bit	1.2/3.3	144 INT-HS LQFP Pb-free
ADSP-21363SKSQ-ENG	0 to 70	333MHz	3M bit	4M bit	1.2/3.3	144 INT-HS LQFP
ADSP-21363SBBCZENG <sup>4</sup>	-40 to 85	333MHz	3M bit	4M bit	1.2/3.3	136 Mini-BGA Pb-free
ADSP-21363SBBC-ENG <sup>4</sup>	-40 to 85	333MHz	3M bit	4M bit	1.2/3.3	136 Mini-BGA
ADSP-21363SBSQZENG <sup>5</sup>	-40 to 85	333MHz	3M bit	4M bit	1.2/3.3	144 INT-HS LQFP Pb-free
ADSP-21363SBSQ-ENG <sup>5</sup>	-40 to 85	333MHz	3M bit	4M bit	1.2/3.3	144 INT-HS LQFP
ADSP-21363SCSQZENG <sup>5</sup>	-40 to 105	200MHz	3M bit	4M bit	1.0/3.3	144 INT-HS LQFP Pb-free
ADSP-21363SCSQ-ENG <sup>5</sup>	-40 to 105	200MHz	3M bit	4M bit	1.0/3.3	144 INT-HS LQFP

<sup>1</sup>Z indicates Lead Free package. For more information about lead free package offerings, please visit [www.analog.com](http://www.analog.com).

<sup>2</sup>See [Thermal Characteristics on Page 37](#) for information on package thermal specifications.

<sup>3</sup>See Engineer-to-Engineer Note TBD for further information.

<sup>4</sup>PCB must have thermal vias. See [Thermal Characteristics on Page 37](#). For more information see JEDEC Standard JESD51-9.

<sup>5</sup>Heat slug must be soldered to the PCB. See [Thermal Characteristics on Page 37](#). For more information see JEDEC Standard JESD51-5.

This datasheet has been download from:

[www.datasheetcatalog.com](http://www.datasheetcatalog.com)

Datasheets for electronics components.