

Precision Rotative Transducers (ROT)

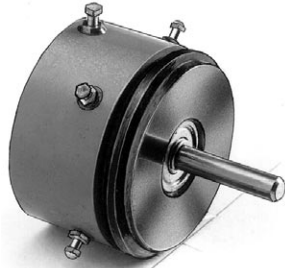

A comprehensive range of rotational motion transducers with trigonometric laws for industrial applications.

FEATURES

- Laws: sine and cosine/sine only/cosine only
- Size 11 - 20
- Continuous Measure on 360°
- Long Life up to 40.10⁶ cycles
- Conformity from ± 1% down to ± 0.35%
- Bushing or Servo Mounting
- Following MIL-R-39023 Requirements

SIZE	11		20	
MODEL	116 SF/Z - S - C	116 BF/Z - S - C	200 SF/Z - S - C	200 BF/Z - S - C
LAW	Z: sine and cosine / S: sine (only) / C: cosine (only)			

ELECTRICAL SPECIFICATIONS	
Theoretical electrical angle (TEA) = 360°	actual electrical angle (AEA) = TEA
Conformity peak to peak	A ≤ ±1% B ≤ ±0.5% down to ≤ ± 0.35%
Number of cups	up to 2
Ohmic values (R _T per quadrant)	1 kΩ - 5 kΩ - 10 kΩ - on request other values
Ohmic value tolerances at 20°C	± 20%
Output smoothness	≤ 0.05%
Maximum power rating at 70°C	0.4W 1.2W
Wiper current	recommended: a few μA - 1mA max. (continuous)
Ground taps	on request
Resistance load on wiper	minimum 10 ³ x R _T
Resolution	essentially infinite
Insulation resistance	≥ 1000MΩ, 500VDC
Dielectric strength	≥ 500VRMS, 50Hz

MECHANICAL SPECIFICATIONS	
Mechanical angle (MA)	360° continuous
Mounting type	servo bushing servo bushing
Shaft guiding	ball bearings sleeve bearings ball bearings sleeve bearings
Shaft	stainless steel
Housing	plastic moulding
Termination	turrets
Wiper	precious metal multi-finger contact
Starting torque (N.cm)	1 cup ≤ 0.3 ≤ 0.5 ≤ 0.4 ≤ 0.6
	2 cups ≤ 0.5 ≤ 0.8 ≤ 0.6 ≤ 0.9
Weight (g)	30 ± 2 (1 cup) + 17 ± 2 (2 cups) 100 ± 3 (1 cup) + 26 ± 3 (2 cups)

PERFORMANCE		
Life (10 ⁶ cycles)	≥ 25 (Servo)	≥ 15 (Bushing)
Temperature range	- 55°C, + 125°C	
Climatic category	55 / 125 / 04	
Speed rotation (RPM)	600 (Servo)	150 (Bushing)
Sine vibration on 3 axes	1.5 mm or 20g from 10Hz to 2000Hz	
Mechanical shocks on 3 axes	50g - 11ms - half sine	

TRIGONOMETRIC FUNCTIONS		
<p>Sine/cosine over 360°</p> <p>LAW Z</p>		$\frac{e_s}{E} \quad \frac{e_c}{E}$ $0^\circ \leq \alpha \leq 360^\circ$ $\beta = \alpha + 90^\circ$
<p>Sine over 360°</p> <p>LAW S</p>		$\frac{e}{E} = \sin \alpha$ $0^\circ \leq \alpha \leq 360^\circ$
<p>Cosine over 360°</p> <p>LAW C</p>		$\frac{e}{E}$ $0^\circ \leq \alpha \leq 360^\circ$

DIMENSIONS in millimeters, general tolerance $\pm 0.5\text{mm}$

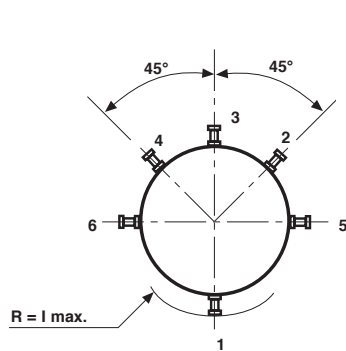

116 SF Z

SIZE 11

116 BF Z

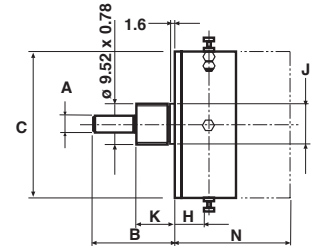
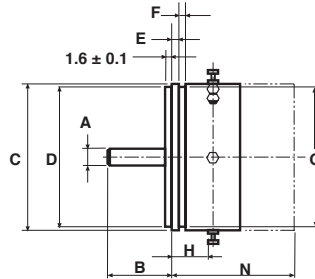

- 1: Power supply (+)
- 2: Power supply (-)
- 3: Wiper (sine)
- 4: Wiper (cosine)
- 5: Ground tap (on request)
- 6: Ground tap (on request)

200 SF Z

SIZE 20

200 BF Z

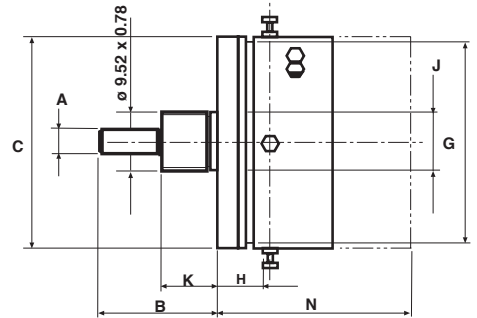
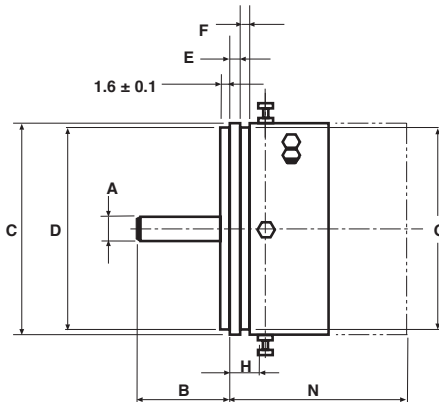
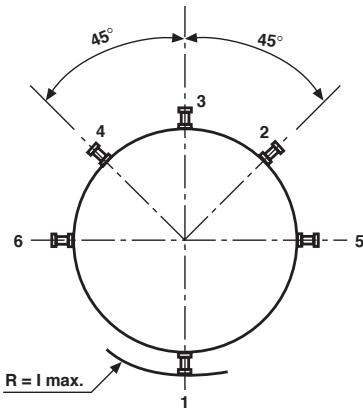

DIMENSIONS mm	A +0 -0.013	B MAX.	C MAX.	D +0 -0.013	E ± 0.1	F MIN.	G MAX.	H MIN.	I MAX.	J +0 -0.02	K MAX.	N MAX. (1 cup)	N MAX. (2 cups)
116 SF Z	3.175	16.6	27.05	24.608	1.6	1.5	24.8	4.5	17.3	-	-	18.5	35
116 BF Z		20	27.05	-	-	-	-	3	-	10.3	9.6	16.5	33
200 SF Z	6.345	16.6	51	47.625	2.4	2.2	47.6	7	29.7	-	-	23.1	41.5
200 BF Z		20	47.6	-	-	-	-	13	-	10.3	9.6	29.5	48

ORDERING INFORMATION

ROT	116	S	F	Z	1	A	502	W...
SERIES	MODEL	MOUNTING TYPE	CONDUCTOR	LAW	NUMBER OF CUPS	CONFORMITY	OHMIC VALUE	MODIFICATIONS
		S: Servo B: Bushing	F: Plastic	Z: Sine/Cosine S: Sine C: Cosine	2 max.	A $\pm 1\%$ B $\pm 0.5\%$	First 2 digits are significant numbers 3rd digit indicates number of zeros	Special feature code number

Special characteristics and designs on request.

This datasheet has been download from:

www.datasheetcatalog.com

Datasheets for electronics components.