



PCM1710U

Sound PLUS Stereo Audio DIGITAL-TO-ANALOG CONVERTER

FEATURES

- **COMPLETE STEREO DAC:**
8X Oversampling Digital Filter
Multi-Level Delta-Sigma DAC
Analog Low Pass Filter
Output Amplifier
- **HIGH PERFORMANCE:**
-92dB THD+N
98dB Dynamic Range
110dB SNR
- **ACCEPTS 16 OR 20 BITS INPUT DATA**
- **SYSTEM CLOCK: 256fs or 384fs**
- **SINGLE +5V POWER SUPPLY**
- **ON-CHIP DIGITAL FILTER:**
Soft Mute and Attenuator
Digital De-emphasis
Double-Speed Dubbing Mode
- **SMALL 28-PIN SOIC PACKAGE**

DESCRIPTION

The PCM1710 is a complete stereo audio digital-to-analog converter, including digital interpolation filter, delta-sigma DAC, and analog voltage output. PCM1710 can accept either 16-bit normal or 20-bit normal input data (MSB first, right justified), or 16-bit IIS data (32-bits per word, continuous clock).

The digital filter performs an 8X interpolation function, as well as special functions such as soft mute, digital attenuation, de-emphasis and double-speed dubbing. Performance of the digital feature is excellent, featuring -62dB stop band attenuation and ± 0.008 dB ripple in the pass band.

PCM1710 is suitable for a wide variety of consumer applications where good performance is required. Its low cost, small size and single +5V power supply make it ideal for automotive CD players, bookshelf CD players, BS tuners, keyboards, MPEG audio, MIDI applications, set-top boxes, CD-ROM drives, CD-Interactive and CD-Karaoke systems.

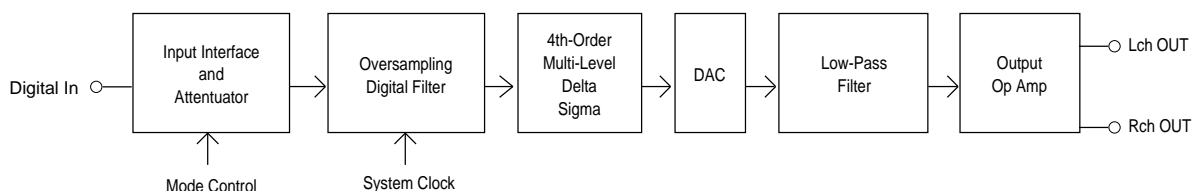

International Airport Industrial Park • Mailing Address: PO Box 11400 • Tucson, AZ 85734 • Street Address: 6730 S. Tucson Blvd. • Tucson, AZ 85706
Tel: (520) 746-1111 • Twx: 910-952-1111 • Cable: BBRCORP • Telex: 066-6491 • FAX: (520) 889-1510 • Immediate Product Info: (800) 548-6132

SPECIFICATIONS

All specifications at +25°C, +V_{CC} = +V_{DD} = +5V, f_S = 44.1kHz, f_{SYS} = 384/256fs, and 16-bit data, unless otherwise noted.

PARAMETER	CONDITIONS	PCM1710U			UNITS
		MIN	TYP	MAX	
RESOLUTION		16		20	Bits
DIGITAL INPUT					
Logic Family					
Input Logic Level (except XTI)					
V _{IH}		2.0			VDC
V _{IL}				0.8	VDC
Input Logic Current (except XTI)				-200	μA
Input Logic Level (XTI)					
V _{IH}		3.2			VDC
V _{IL}				1.4	VDC
Input Logic Current (XTI)				±50	μA
Output Logic Level (CLKO):					
V _{OH}		4.5			VDC
V _{OL}				0.5	VDC
Output Logic Current (CLKO)		±10			mA
Data Format	Normal (16/20-bit)/IIS (16-bit) selectable				
Sampling Frequency		32	44.1	48	kHz
System Clock Frequency	384f _S	12.288	16.934	18.432	MHz
System Clock Frequency	256f _S	8.192	11.2894	12.288	MHz
DC ACCURACY					
Gain Error			±1.0	±5.0	% of FSR
Gain Mis-Match Channel-To-Channel			±1.0	±5.0	% of FSR
Bipolar Zero Error	V _O = 1/2V _{CC} at Bipolar Zero		±20.0		mV
Gain Drift			±50		ppm of FSR/°C
Bipolar Gain Drift			±20		ppm of FSR/°C
DYNAMIC PERFORMANCE⁽¹⁾					
THD+N at F/S (0dB) ⁽²⁾	f _{IN} = 991kHz		-92	-88	dB
THD+N at -60dB ⁽²⁾	f _{IN} = 991kHz		-36	-32	dB
Dynamic Range	EIAJ A-weighted		98		dB
S/N Ratio	EIAJ A-weighted	104	110		dB
Channel Separation		90	94		dB
DIGITAL FILTER PERFORMANCE					
Pass Band Ripple	Normal Mode			±0.008	dB
Pass Band Ripple	Double Speed Mode			±0.018	dB
Stop Band Attenuation	Normal Mode	-62			dB
Stop Band Attenuation	Double Speed Mode	-58			dB
Pass Band	Normal Mode			0.4535	fs
Pass Band	Double Speed Mode			0.4535	fs
Stop Band	Normal Mode			0.5465	fs
Stop Band	Double Speed Mode			0.5465	fs
De-emphasis Error	(f _S 32kHz ~ 48kHz)	-0.05		+0.03	dB
ANALOG OUTPUT					
Voltage Range			3.2		V _{p-p}
Load Impedance		5			kΩ
Center Voltage			+1/2V _{CC}		V
POWER SUPPLY REQUIREMENTS					
Voltage Range: +V _{CC}		+4.5	+5.0	+5.5	VDC
+V _{DD}		+4.5	+5.0	+5.5	VDC
Supply Current (+I _{CC}) + (+I _{DD})			45	70	mA
TEMPERATURE RANGE					
Operation		-25		+85	°C
Storage		-55		+100	°C

NOTE: (1) Dynamic performance specs are tested with external 20kHz low pass filter. (2) 30kHz LPF, 400Hz HPF, Average Mode. Shibusoku #725 THD Meter.

The information provided herein is believed to be reliable; however, BURR-BROWN assumes no responsibility for inaccuracies or omissions. BURR-BROWN assumes no responsibility for the use of this information, and all use of such information shall be entirely at the user's own risk. Prices and specifications are subject to change without notice. No patent rights or licenses to any of the circuits described herein are implied or granted to any third party. BURR-BROWN does not authorize or warrant any BURR-BROWN product for use in life support devices and/or systems.

PIN ASSIGNMENTS

PIN NAME	NUMBER	FUNCTION
Input Interface Pins		
LRCIN	1	Sample Rate Clock Input. Controls the update rate (fs).
DIN	2	Serial Data Input. MSB first, right justified format contains a frame of 16-bit or 20-bit data.
BCKIN	3	Bit Clock Input. Clocks in the data present on DIN input.
Mode Controls and Clock Signals		
CLKO	4	Buffered Output of Oscillator. Equivalent to fs.
XTI	5	Oscillator Input (External Clock Input). For an internal clock, tie XTI to one side of the crystal oscillator. For an external clock, tie XTI to the output of the chosen external clock.
XTO	6	Oscillator Output. When using the internal clock, tie to the opposite side (from pin 5) of the crystal oscillator. When using an external clock, leave XTO open.
CKSL	23	System Clock Select. For 384fs, tie CKSL "High". For 256fs, tie CKSL "Low".
MODE	24	Operation Mode Select. For serial mode, tie MODE "High". For parallel mode, tie MODE "Low".
MUTE	25	Mute Control. To disable soft mute, tie MUTE "High". To enable soft mute, tie MUTE "Low".
MD/DM1	26	Mode Control for Data/De-emphasis. See "Mode Control Functions" on page 11.
MC/DM2	27	Mode Control for BCKIN/De-emphasis. See "Mode Control Functions" on page 11.
ML/DSD	28	Mode Control for WDCK/Double speed dubbing. See "Mode Control Functions" on page 11.
Analog Functions		
V _{OUTR}	13	Right Channel Analog Output.
V _{OUTL}	16	Left Channel Analog Output.
Power Supply Connections		
DGND	7, 22	Digital Ground.
V _{DD}	8, 21	Digital Power Supply (+5V).
V _{CC2R}	9	Analog Power Supply (+5V), Right Channel DAC.
AGND2R	10	Analog Ground (DAC), Right Channel.
EXT1R	11	Output Amplifier Common, Right Channel. Bypass to ground with a 10µF capacitor.
EXT2R	12	Output Amplifier Bias, Right Channel. Connect to EXT1R.
AGND	14	Analog Ground.
V _{CC}	15	Analog Power Supply (+5V).
EXT2L	17	Output Amplifier Bias, Left Channel. Connect to EXT1L.
EXT1L	18	Output Amplifier Common, Left Channel. Bypass to ground with a 10µF capacitor.
AGND2L	19	Analog Ground (DAC), Left Channel.
V _{CC2L}	20	Analog Power Supply (+5V), Left Channel DAC.

ABSOLUTE MAXIMUM RATINGS

Power Supply Voltages	±6.5VDC
+V _{CC} to V _{DD} Voltage	±0.1V
Input Logic Voltage	-0.3V to V _{DD} +0.3V
Power Dissipation	400mW
Operating Temperature Range	-25°C to +85°C
Storage Temperature Range	-55°C to +125°C
Lead Temperature (soldering, 5s)	+260°C

PACKAGE INFORMATION

MODEL	PACKAGE	PACKAGE DRAWING NUMBER ⁽¹⁾
PCM1710U	28-Pin SOIC	217

NOTE: (1) For detailed drawing and dimension table, please see end of data sheet, or Appendix D of Burr-Brown IC Data Book.

PIN CONFIGURATION

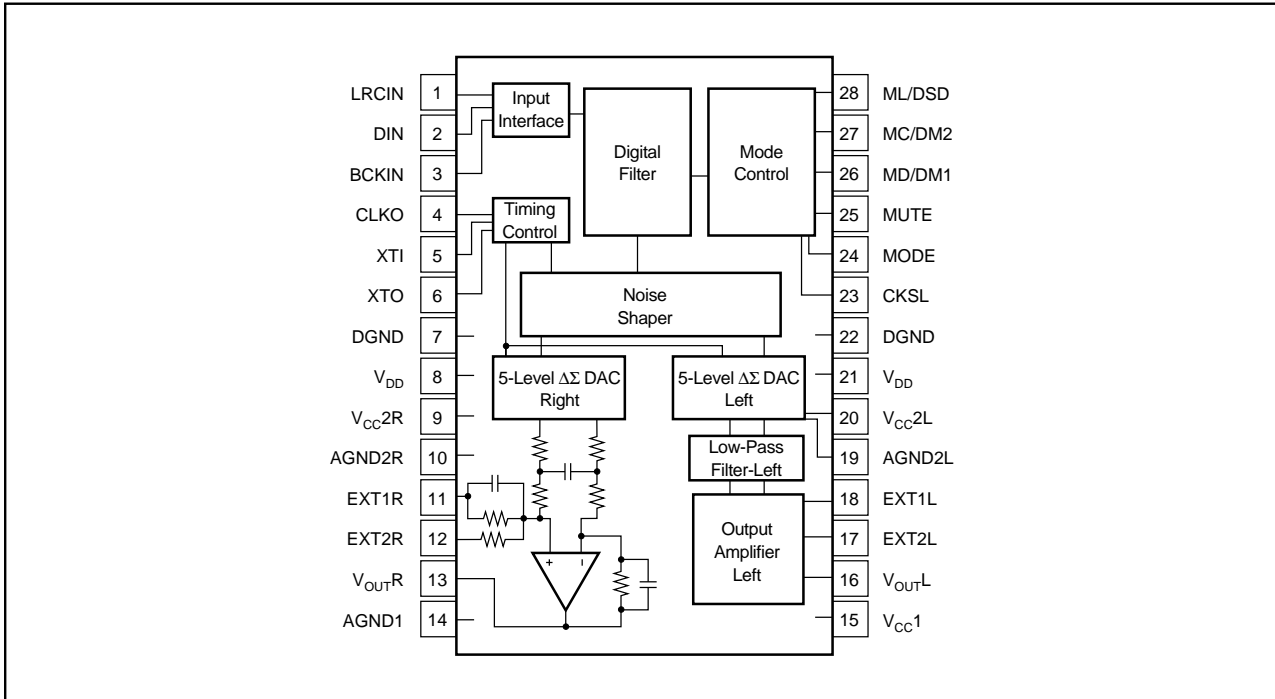

CONNECTION DIAGRAM

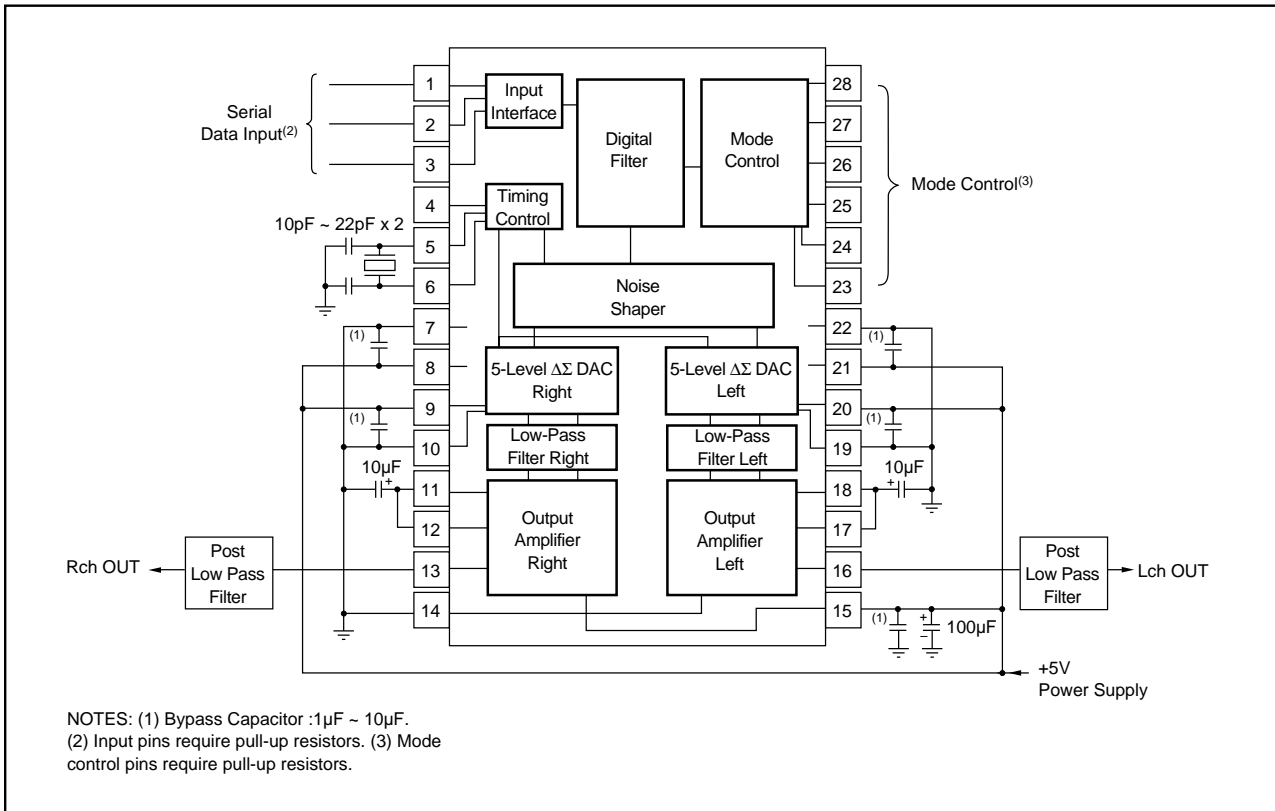

DATA INPUT TIMING

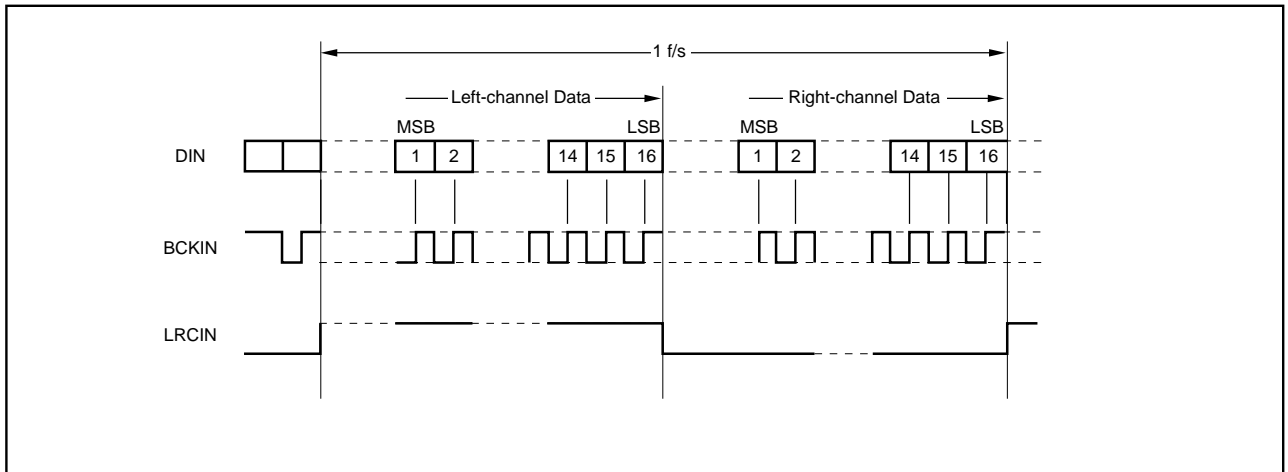

FIGURE 1. Normal Format, 16-Bit (LRCIN H: Lch).

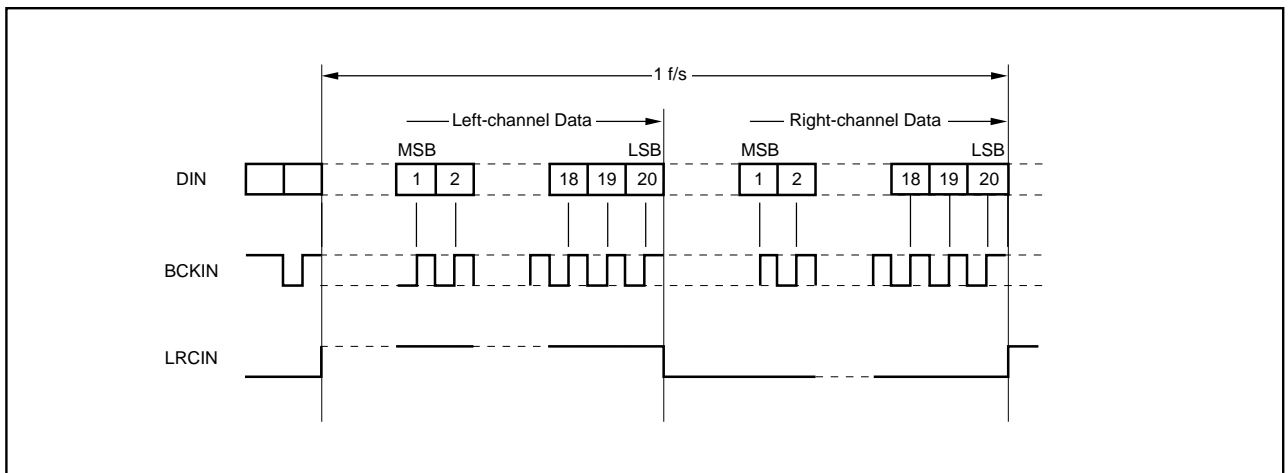

FIGURE 2. Normal Format, 20-Bit (LRCIN H: Lch).

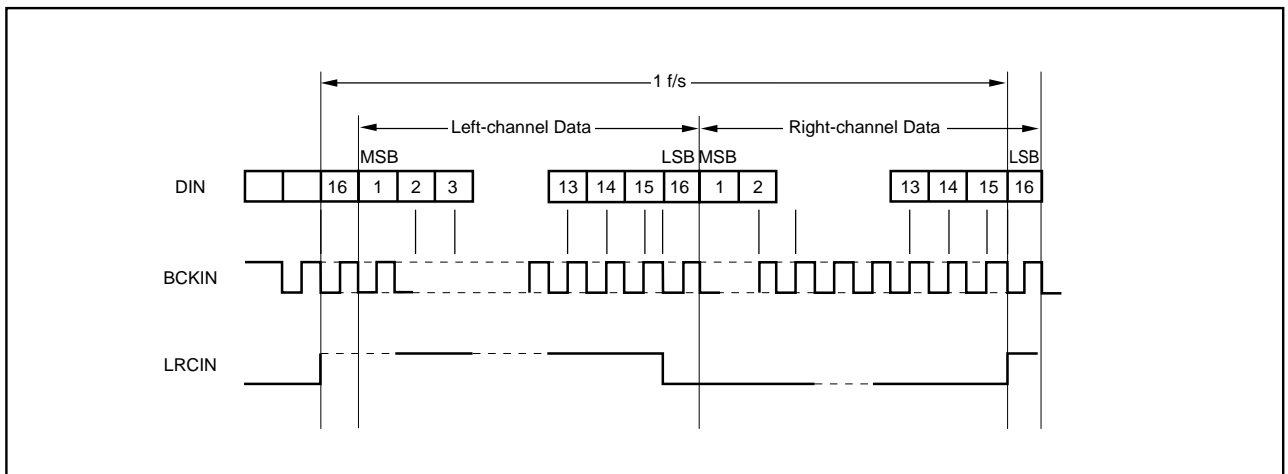

FIGURE 3. IIS Format, (16-Bit, 32 BCKIN Clock Cycles Per fs Interval).

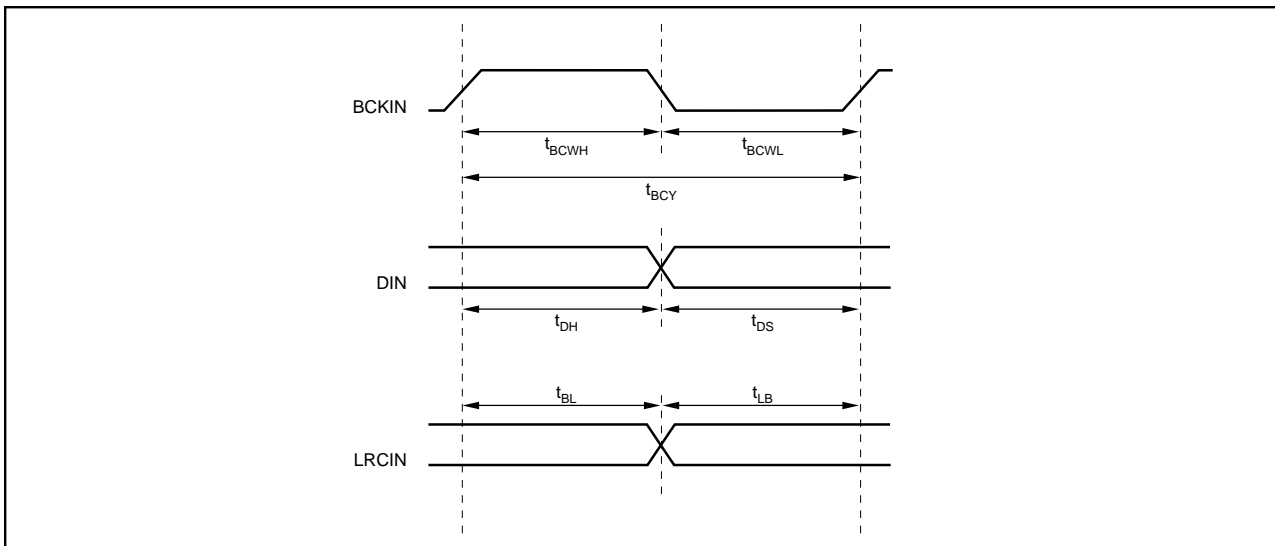

FIGURE 4. Data Input Timing.

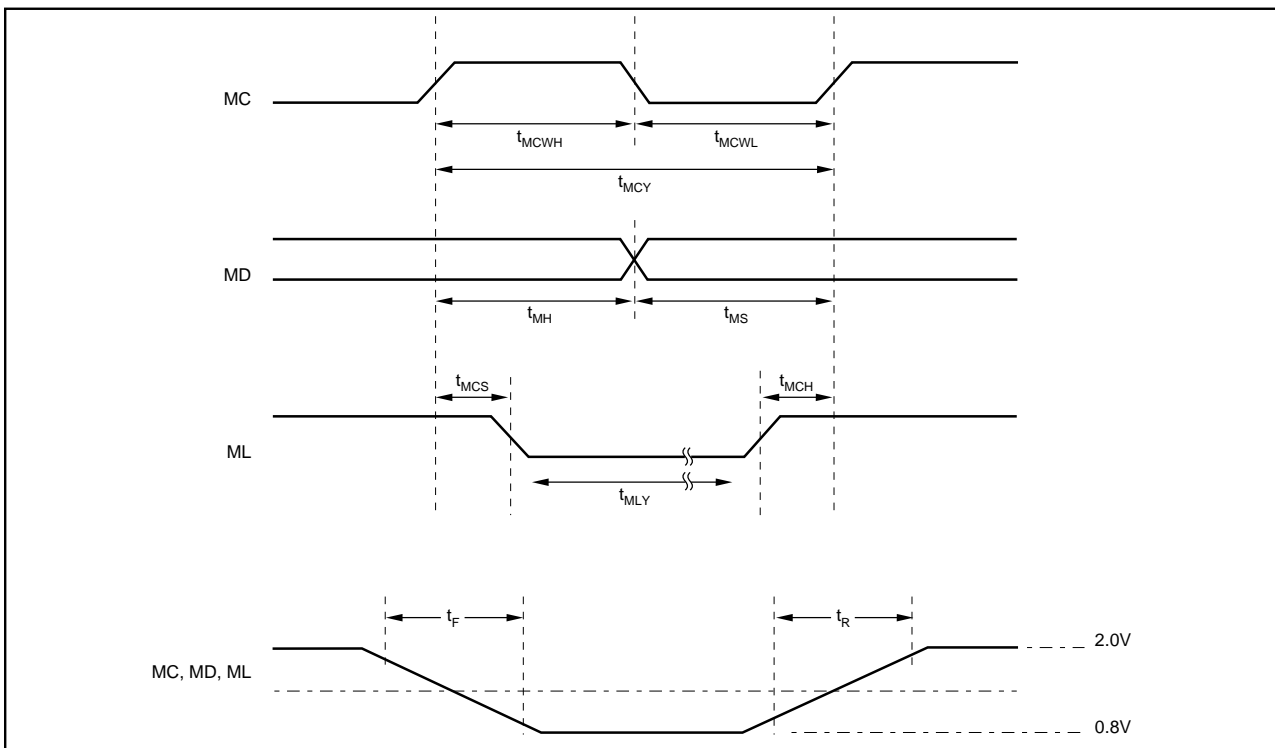

FIGURE 5. Serial Mode Control Timing.

BCK Pulsewidth (H Level)	t_{BCWH}	70ns (min)
BCK Pulsewidth (L Level)	t_{BCWL}	70ns (min)
BCK Pulse Cycle Time	t_{BCY}	140ns (min)
DIN Setup Time	t_{DS}	30ns (min)
DIN Hold Time	t_{DH}	30ns (min)
BCK Rising Edge → LRCI Edge	t_{BL}	30ns (min)
LRC I Edge → BCK Rising Edge	t_{LB}	30ns (min)

TABLE I. Data Input Timing Specifications (Refer to Figure 4).

MC Pulsewidth (H Level)	t_{MCWH}	50ns (min)
MC Pulsewidth (L Level)	t_{MCWL}	50ns (min)
MC Pulse Cycle Time	t_{MCY}	100ns (min)
MD Setup Time	t_{MS}	30ns (min)
MD Hold Time	t_{MH}	30ns (min)
ML Setup Time	t_{MCS}	30ns (min)
ML Hold Time	t_{MCH}	30ns (min)
ML Low-Level Time	t_{MLY}	$1/\text{sysclk} + 20\text{ns (min)}$
MC, MD, ML Rise Time	t_R	15ns (max)
MC, MD, ML Fall Time	t_F	15ns (max)

TABLE II. Serial Mode Control Timing Specifications (Refer to Figure 5).

TYPICAL PERFORMANCE CURVES

All specifications at +25°C, +V_{CC} = +V_{DD} + 5V, f_s = 44.1kHz, f_{sys} = 384/256fs, and 16-bit data, unless otherwise noted.

DIGITAL FILTER

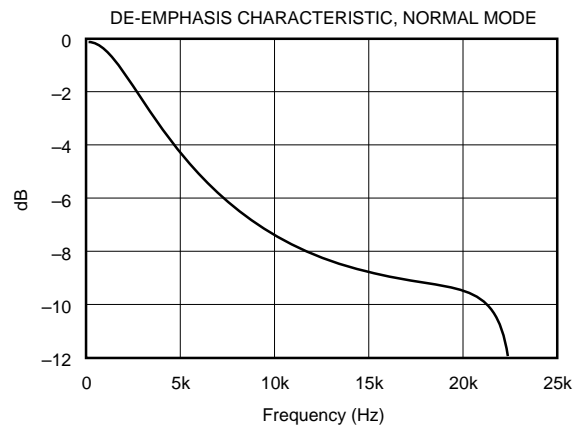
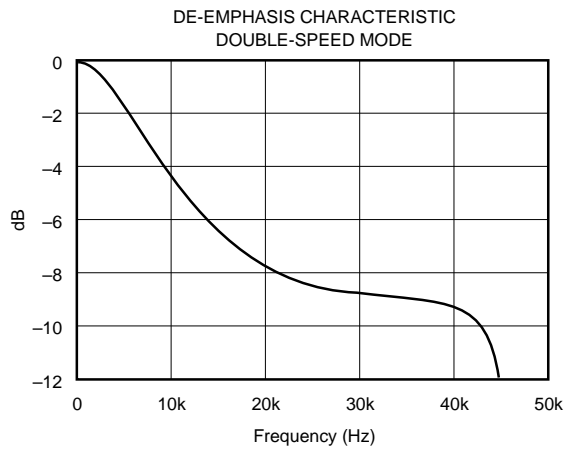
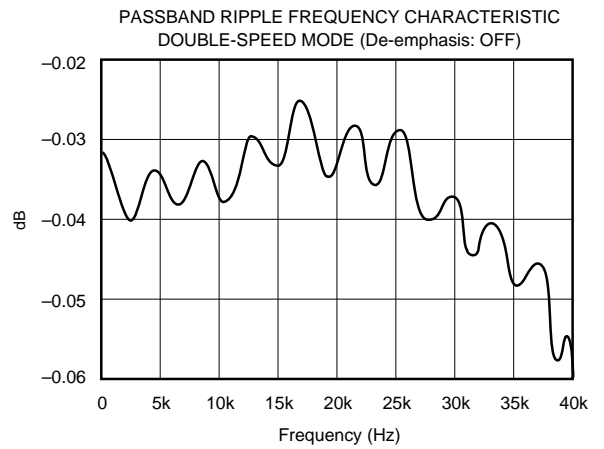
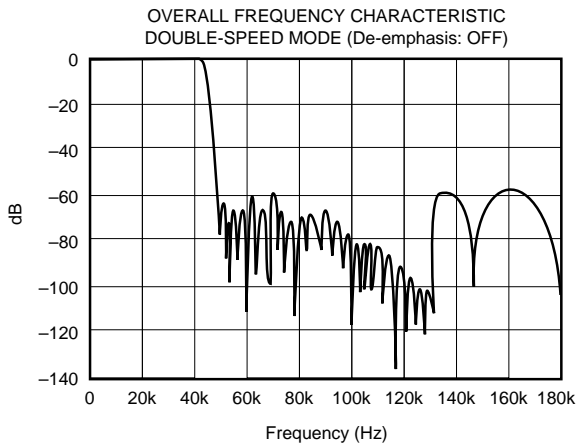
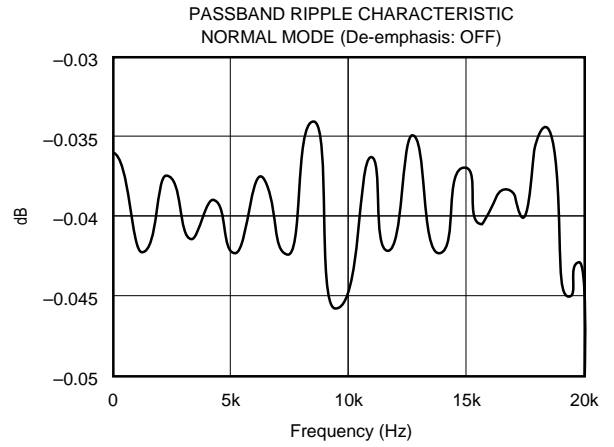
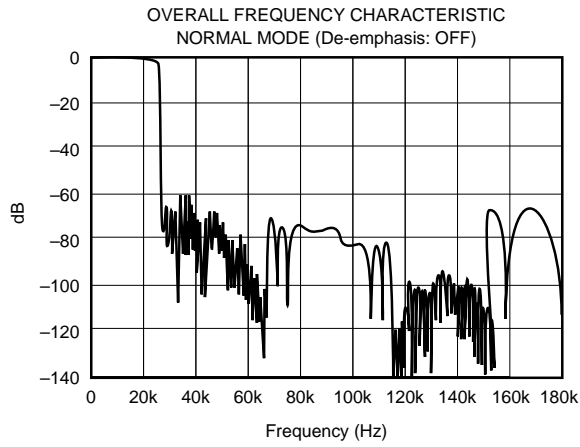

TYPICAL PERFORMANCE CURVES (CONT)

At $T_A = +25^\circ\text{C}$, $V_S = \pm 5\text{V}$, $R_L = 100\Omega$, $C_L = 2\text{pF}$, and $R_{FB} = 402\Omega$, unless otherwise noted. Based on 200 piece sample from 3 diffusion runs.

DYNAMIC PERFORMANCE

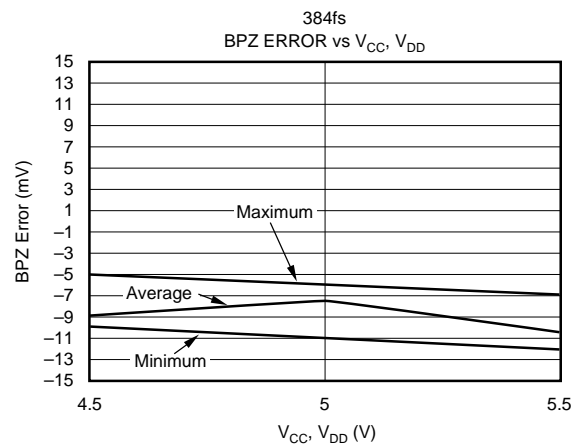
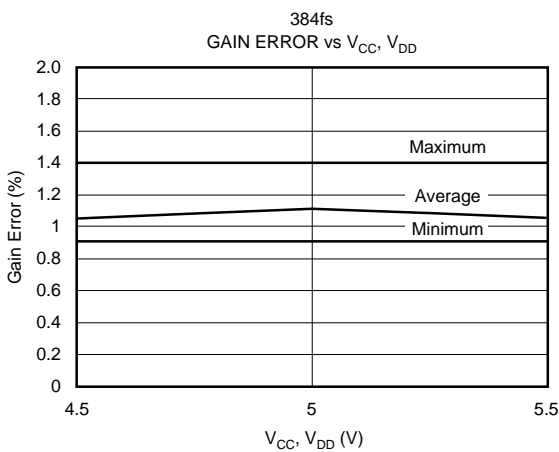
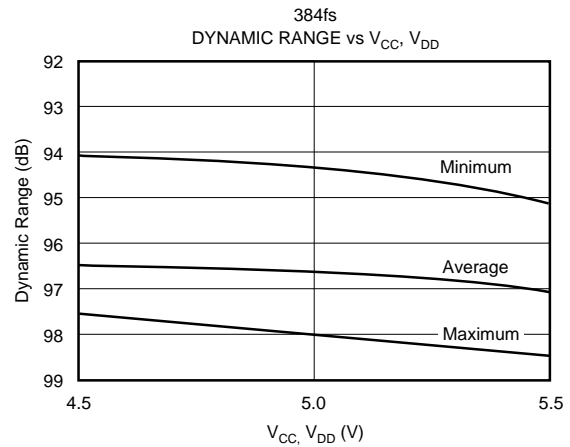
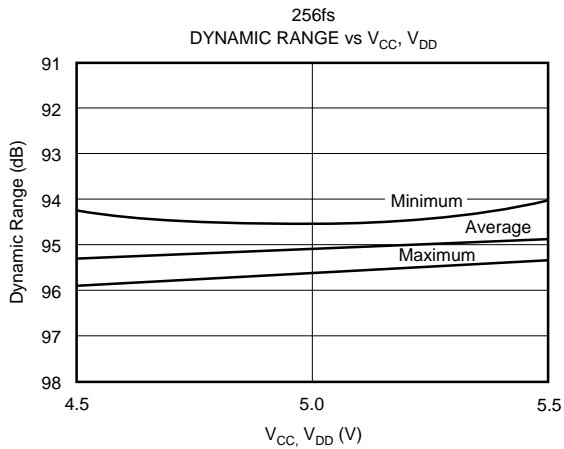
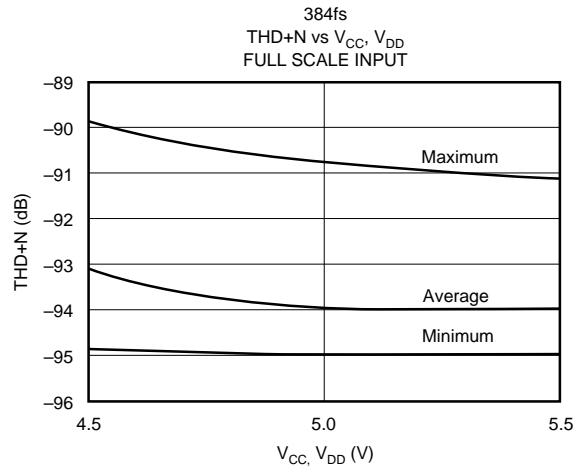
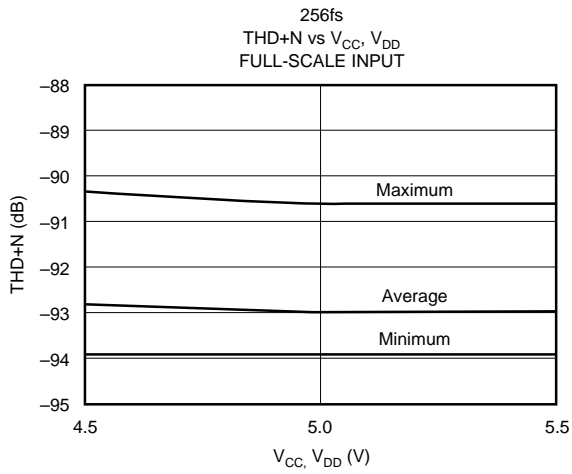

TYPICAL PERFORMANCE CURVES (CONT)

At $T_A = +25^\circ\text{C}$, $V_S = \pm 5\text{V}$, $R_L = 100\Omega$, $C_L = 2\text{pF}$, and $R_{FB} = 402\Omega$, unless otherwise noted. Based on 200 piece sample from 3 diffusion runs.

DYNAMIC PERFORMANCE

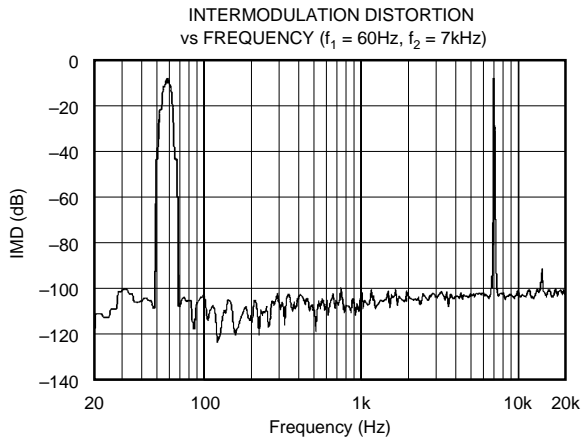
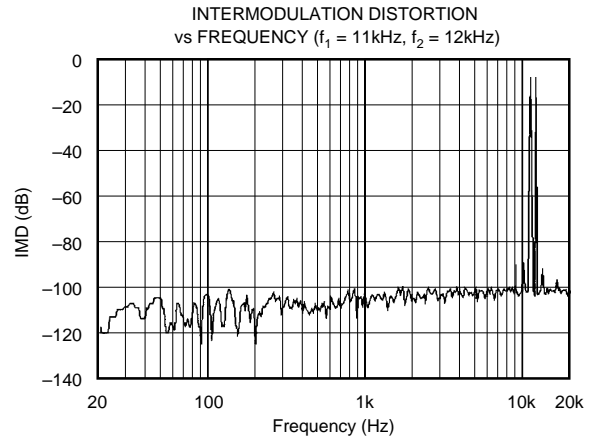
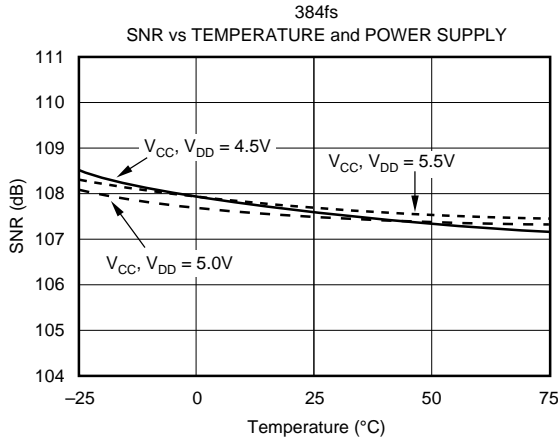

CAUTION: Minimum and maximum values on typical performance curves are not meant to imply a guarantee. Curves should be used for reference only. Refer to specification for guaranteed performances.

FUNCTIONAL DESCRIPTION

PCM1710 has several built-in functions including digital attenuation, digital de-emphasis and soft mute. These functions are software controlled. PCM1710 can be operated in two different modes, **Serial** or **Parallel**. Serial Mode is a three-wire interface using pin 26 (MD), pin 27 (MC), and pin 28 (ML). Data on these pins are used to control de-emphasis mode, mute, double-speed dubbing, input resolution and input format. PCM1710 can also be operated in parallel mode, where static control signals are used on pin 26 (DM1), pin 27 (DM2), and pin 28 (DSD). Operation of both of these modes are covered in detail in the next sections.

CAUTION: Mode control signals operate on level triggered logic. The minimum timing conditions detailed in Figures 5 and 6 **MUST** be observed.

MODE CONTROL: SERIAL/PARALLEL SELECTION

MODE = H	Serial Mode
MODE = L	Parallel Mode

TABLE III. Serial and Parallel Mode are Selectable by MODE Pin (Pin 24).

MODE CONTROL: SELECTABLE FUNCTIONS

FUNCTION	SERIAL MODE (MODE = H)	PARALLEL MODE (MODE = L)
Input Data Format Selection	0	X(Normal Mode Fixed)
Input Data Bit Selection	0	X(16-bit Fixed)
Input LRCI Polarity Selection	0	X
De-emphasis Control	0	0
Mute	0	0
Attenuation	0	X
Double Speed Dubbing	0	0

NOTE: 0: Selectable, X: Not Selectable.

TABLE IV. Selectable Functions in Serial Mode and Parallel Mode.

Table IV indicates which functions are selectable within the user's chosen mode. All of the functions shown are selectable within the serial mode, but only de-emphasis control, mute and double-speed dubbing may be selected when using PCM1710 in the parallel mode.

PARALLEL-MODE: DE-EMPHASIS CONTROL (PIN 24 [MODE] = L)

DM1 (Pin 26)	DM2 (Pin 27)	De-emphasis
L	L	OFF
H	L	32kHz
L	H	48kHz
H	H	44.1kHz

TABLE V. De-emphasis (Pins 26 and 27).

In the parallel mode, de-emphasis conditions are controlled by the logic levels on pin 26 (DM1) and pin 27 (DM2). For PCM1710, de-emphasis can operate at 32kHz, 44.1kHz, 48kHz, or disabled.

PARALLEL-MODE: DOUBLE-SPEED DUBBING CONTROL (PIN 24 [MODE] = L)

DSD = H	Normal Mode
DSD = L	Double-Speed Dubbing Mode

NOTE: When the Double-Speed Dubbing Mode is selected, the System Clock must be 384fs (CKSL: Pin 23 = H).

TABLE VI. DSD (Pin 28).

In the parallel mode, double-speed dubbing can be enabled by holding pin 28 (DSD) at a logic "low".

CAUTION: Double-speed dubbing cannot operate if the system clock is set at 256fs.

SERIAL MODE CONTROL

In order to use all of PCM1710's functionality, the **serial mode control** should be used. PCM1710 must be addressed three separate times to set all of the various registers and flags that control these functions.

Table VII together with Figure 6 details the control of the PCM1710 in the serial mode. Internal latches are used to hold this serial data until the PCM1710 is enabled to use the data. The serial mode is used by applying clocked data to the following pins:

NAME	PIN	FUNCTION
MC	27	Clock for Strobing in Data
ML	28	Latches Data into the Registers
MD	26	8-bit Data Word Defining Operation

	B0	B1	B2	BIT NO.	MODE FLAG	FUNCTION MODE SELECTION				MODE BY DEFAULT	
						MODE	BIT VALUE	SELECTED FUNCTION			
Mode 1	H	L	L	B3	DEEM2	Sampling Frequency for De-emphasis		DEEM2		OFF	
				B4	DEEM1			0	1		
					DEEM1			0	48kHz		
					1			32kHz	44.1kHz		
				B5	IIR	De-emphasis	0	De-emphasis OFF			OFF
							1	De-emphasis ON			
				B6	MUTE	Mute	0	Mute OFF			OFF
			1	Mute ON							
B7	DSD	Double-Speed	0	Double-speed OFF		OFF					
			1	Double-speed ON							
Mode 2	H	L	H	B3		Not Assigned					
				B4	TST	Test Mode	0	Infinite Zero Detection OFF		ON	
							1	Infinite Zero Detection ON			
				B5	IW	Input Resolution	0	16-Bit		16-Bit	
							1	20-Bit			
				B6	LRPL	Polarity for LRCL	0	Lch:high/Rch:low		Lch:high Rch:low	
							1	Lch:low/Rch:high			
B7	IIS	Input Format	0	Normal		Normal					
			1	IIS							

TABLE VII. Serial-Mode Control Input Format (Pin 24 [MODE] = H)—Refer to Figure 6 for Timing Diagram.

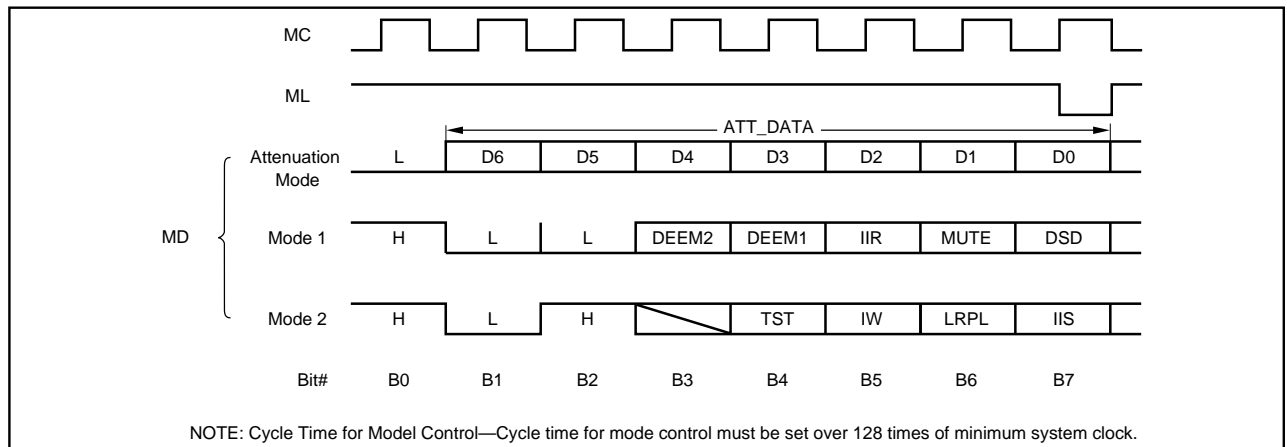

FIGURE 6. Mode Control Input Format, Serial Mode.

DIGITAL ATTENUATION

One of the functions which can be implemented through use of the serial mode control is attenuation. This function allows the user to control the level of the output, independent of the of the input level set by the actual input data supplied to the DAC.

Referring to Figure 6, when the first data bit (B0) on MD (pin 26) is low, the attenuation function is enabled. The next seven bits (B1 - B6) define a binary value, ATT_DATA, that indicates the desired level of attenuation. The attenuation level is given by:

$$\text{Level} = 20\log_{10} (1 - \text{ATT_DATA}/127) \text{ dB}$$

When all 7 bits of the ATT_DATA word are high (ATT_DATA = 127), attenuation is infinite and the output of PCM1710 will be zero.

MODE 1 CONTROLS

This mode can be enabled with the sequence of 1, 0, 0 as the first three bits on MD (pin 26). This mode allows for the following functions:

De-emphasis	On/Off
De-emphasis Frequency	32kHz, 44.1kHz, 48kHz
Soft Mute	On/Off
Double-Speed Dubbing	On/Off

DIGITAL DE-EMPHASIS

PCM1710 allows three different sampling rates for digital de-emphasis. B3 and B4 are used for binary control of the de-emphasis frequency:

B3	B4	Frequency
0	0	OFF
0	1	48kHz
1	0	32kHz
1	1	44.1kHz

Once the reset has been established on pin 27 (MC), the de-emphasis frequency defaults to 44.1kHz. B5 is a master control for de-emphasis. A high level on B5 enables de-emphasis (frequency controlled by B3 and B4), and a low level on B5 disables de-emphasis.

SOFT MUTE

Soft mute is enabled when B6 is high. The soft mute occurs gradually, unlike the forced infinite zero detection. When the mute data bit is high, complete muting will occur in $127/f_s$ seconds. For $f_s = 44.1\text{kHz}$, complete mute will occur in 2.88ms.

DOUBLE-SPEED DUBBING

Double-speed dubbing is used when the application allows for the CD to be copied at twice the normal playback rate. Double-speed dubbing is enabled when B7 is high. This mode can only operate when the system clock is set at 384fs. Double-speed dubbing can only occur when the sample rate is 44.1kHz. Since f_s is set at 44.1kHz, the system clock in double-speed mode is at 192fs.

MODE 2 CONTROLS

Mode 2 is enabled when B0 is high, B1 is low, and B2 is high. This mode controls infinite zero detection, input resolution, LRCI polarity and input format.

INFINITE ZERO DETECTION

B4 is used to enable or disable infinite zero detection. PCM1710 monitors both data input (DIN) and bit clock (BCKIN). When the data input is continuously zero or one for 65,536 cycles of the bit clock, infinite zero detection occurs, which forces the output of the PCM1710 to one-half of V_{CC} (typically 2.5V). Once this happens, only the output amplifier is connected. This is done to avoid having the noise shaped output spectrum of the DAC appear at the output of the PCM1710. This function is especially useful for CD applications when the player is between tracks. An inherent attribute of all delta-sigma architectures is the presence of quantization noise when the input is constant (all 1s or 0s). When the zero detect circuit disconnects the DAC from the output amplifier, a very low level “click” noise may be audible. The click noise occurs at approximately -76dB , and in many cases is inaudible.

INPUT RESOLUTION

PCM1710 is capable of accepting either 16-bit or 20-bit input data. Specifications for PCM1710 are tested and guaranteed using 16-bit data. When 20 bits are used, dynamic performance is improved by approximately 2dB. Refer to “Typical Performance Curves” for a comparison of 16-bit and 20-bit data. A low on B5 places PCM1710 in 16-bit mode, and a high on B5 sets PCM1710 to 20-bit mode.

SAMPLE RATE CLOCK POLARITY

B6 controls the polarity of the sample rate clock (LRCIN) polarity. When B6 is low, data will be accepted on the left channel when LRCIN is high, and on the right channel when LRCIN is low. When B6 is high, data will be accepted on the right channel when LRCIN is high, and on the left channel when LRCIN is low.

INPUT FORMAT

Normal input mode for PCM1710 is MSB first, right justified. PCM1710 may also be operated with IIS (32 continuous clock cycles per word) input format. When B7 is low, the input format is “normal”. When B7 is high, the input format is “IIS”. However, PCM1710 can only accept IIS input format when it is in 16-bit mode. 20-bit data must be entered in normal mode.

DEFAULT MODE

At initial power-on, default settings for PCM1710 are 44.1kHz f_s , de-emphasis off, mute off, double-speed off, infinite zero detect on, 16-bit input LRCIN left channel high, and normal input mode.

SYSTEM CLOCK

SAMPLING FREQUENCY	SYSTEM CLOCK FREQUENCY
32kHz	256fs 8.1920MHz
32kHz	384fs 12.2880MHz
44.1kHz	256fs 11.2896MHz
44.1kHz	384fs 16.9344MHz
48kHz	256fs 12.2880MHz
48kHz	384fs 18.4320MHz

TABLE VIII. Relationship of f_s and System Clock.

NORMAL/DOUBLE-SPEED DUBBING

For most CD playback applications operating at 384fs, the system clock frequency must be 16.9344MHz, in both the normal mode and double-speed dubbing mode. Table VIII illustrates the relationship between f_s and output clock frequency in both modes.

PARAMETER	ML/DSD (PIN 28)	
	H (Normal)	L (Double Speed)
XTI Input Clock Frequency	384fs	192fs
XTI Frequency	16.9344MHz ($f_s = 44.1\text{kHz}$)	16.9344MHz ($f_s = 88.2\text{kHz}$)
CLKO Output Clock Frequency	384fs	192fs

TABLE IX. Relationship Between Normal/Double Speed and f_s .

EXTERNAL SYSTEM CLOCK

Figure 7 is a diagram showing the internal clock in conjunction with an external crystal oscillator.

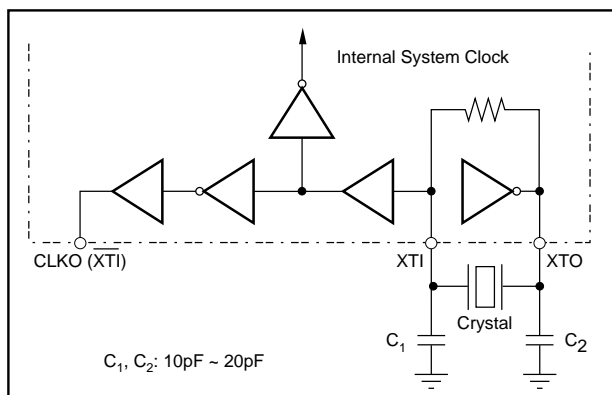

FIGURE 7. External Crystal Oscillator.

Figure 8 is a diagram showing the internal clock with an external clock source, instead of an oscillator. An external system clock (input to XTI) must meet the following conditions:

HIGH LEVEL	$V_{IH} > 0.64V_{DD}$	$T_H > 10ns$
LOW LEVEL	$V_{IL} > 0.28V_{DD}$	$T_L > 10ns$

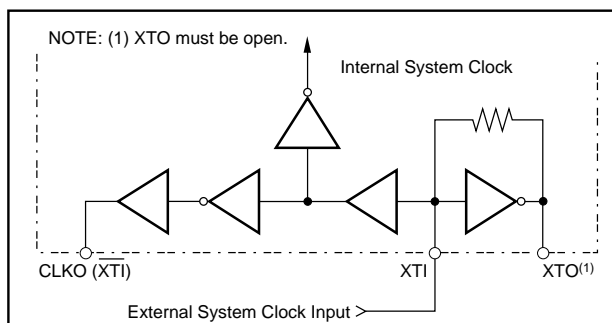

FIGURE 8. External System Clock.

POWER SUPPLY CONNECTIONS

PCM1710 has two power supply connections: digital (V_{DD}) and analog (V_{CC}). Each connection also has a separate ground. If the power supplies turn on at different times, there is a possibility of a latch-up condition. To avoid this condition, it is recommended to have a common connection between the digital and analog power supplies. If separate supplies are used without a common connection, the delta between the two supplies during ramp-up time must be less than 0.6V.

An application circuit to avoid a latch-up condition is shown in Figure 9.

BYPASSING POWER SUPPLIES

The power supplies should be bypassed as close as possible to the unit. Refer to Figure 19 for optimal values of bypass capacitors. For applications which require very high perfor-

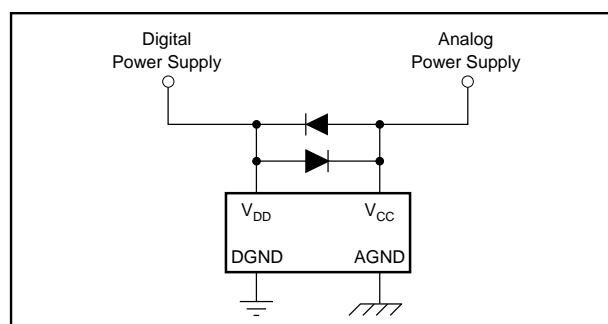

FIGURE 9. Latch-up Prevention Circuit.

mance at low levels (such as keyboards, synthesizers, etc.) it may be beneficial to provide additional bypassing on pin 15 (V_{CC1}) with a low ESR 100 μ F capacitor. This will eliminate stray tones which may be above the noise floor.

THEORY OF OPERATION

PCM1710 is an oversampling delta-sigma D/A converter, consisting of an input interface/attenuator, a 4th-order multi-level delta-sigma modulator, a low pass filter and an output amplifier (see Figure 10).



MODULATOR

The delta-sigma section of the PCM1710 is based on a 5-level amplitude quantizer and a 4th-order filter. This converts oversampled 16- or 20-bit input data to 5-level delta-sigma format. A block diagram of the 5-level modulator is shown in Figure 11.

This 5-level delta-sigma modulator has the advantage of improved stability and jitter sensitivity over the typical one bit (2-level) delta-sigma modulator.

The combined oversampling rate of the delta-sigma modulator and the internal 8X oversampling digital filter is 48fs at a system clock of 384fs and 32fs at a system clock of 256fs.

A block diagram of the 4th-order filter section $H_f(z)$ in the delta-sigma modulator is shown in Figure 12.

In general, high order one-bit delta-sigma modulators have disadvantages due to loop instability (multiple integration stages). The five level delta-sigma modulator of the PCM1710 uses phase compensation techniques to obtain stable operation. In Figure 12, the coefficients B1 to B4 give the basic form of the filter, and A2 to A4 are used for phase compensation of the feedback loop.

The theoretical quantization noise performance of five level delta-sigma modulator is shown in Figure 13 and 14. In the audio band, the quantization noise floor level of the PCM1710 is less than 130dB (at a system clock of 384fs).

APPLICATION CONSIDERATIONS

16-BIT vs 20-BIT OPERATION

In the serial mode, PCM1710 can be configured to accept either 16-bit or 20-bit data. The specifications listed in this data sheet are the 16-bit data. Some improvements in dynamic performance can be realized by using 20-bit data. Internally, the PCM1710's digital filter uses only 20-bit data. If the input data is 16-bit, the filter adds four zeros to complete the 20-bit input word. Typical performance differences between 16-bit and 20-bit data are shown in Tables X and XI.

DATA	256fs	384fs
16-bit	-91dB	-93dB
20-bit	-94dB	-96dB

TABLE X. THD+N Performance at Full Scale.

DATA	256fs	384fs
16-bit	94dB	96dB
20-bit	96dB	98dB

TABLE XI. Dynamic Range.

DELAY TIME

There is a finite delay time in delta-sigma converters. In A/D converters, this is commonly referred to as latency. For a delta-sigma D/A converter, delay time is determined by the order number of the FIR filter stage, and the chosen sampling rate. The following equation expresses the delay time of PCM1710:

$$T_D = 22.625 \times 1/f_s$$

$$\text{For } f_s = 44.1\text{kHz}, T_D = 22.625/44.1\text{kHz} = 513.04\mu\text{s}$$

Applications using data from a disc or tape source, such as CD audio, CD-Interactive, Video CD, DAT, Minidisc, etc., generally are not affected by delay time. For some professional applications such as broadcast audio for studios, it is important for total delay time to be less than 2ms.

INTERNAL RESET

If the sample rate clock (LRCIN) is stopped during operation, the infinite zero detect circuit will cause the output to go to $V_{CC}/2$ after 65,536 cycles of the bit clock (BCKIN). Once a new system clock has been applied, there will be a delay until output data is correlated to the input. This is due to the digital delay of the filter.

When power is first applied to PCM1710, an automatic reset function occurs after 64 cycles of LRCIN.

CHANGING SAMPLING RATE

For normal operation, LRCIN and XTI should be synchronized at either 256fs or 384fs. When the sampling rate is

changed during operation, output data is invalid during the delay period (T_D) and for two subsequent cycles of LRCIN. After two cycles of LRCIN, the output is a valid representation of the input data.

OUTPUT FILTERING

For testing purposes all dynamic tests are done on the PCM1710 using a 20kHz low pass filter. This filter limits the measured bandwidth for THD+N, etc. to 20kHz. Failure to use such a filter will result in higher THD+N and lower SNR and Dynamic Range readings than are found in the specifications. The low pass filter removes out of band noise. Although it is not audible, it may affect dynamic specification numbers.

The performance of the internal low pass filter from DC to 24kHz is shown in Figure 15. The higher frequency rolloff of the filter is shown in Figure 16. If the user's application has the PCM1710 driving a wideband amplifier, it is recommended to use an external low pass filter. A simple 3rd-order filter is shown in Figure 17. For some applications, a passive RC filter or 2nd-order filter may be adequate.

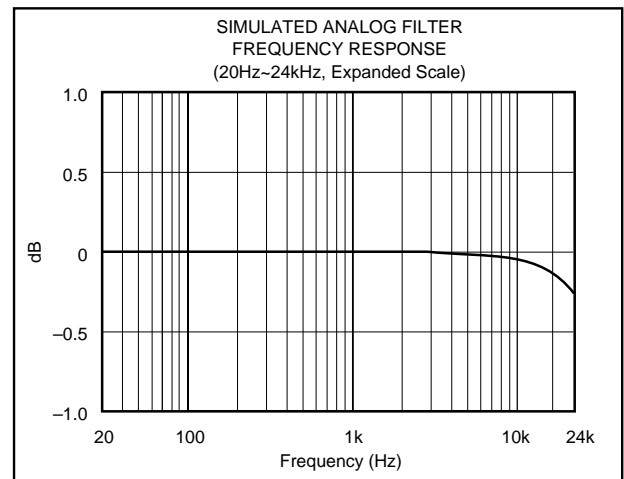

FIGURE 15. Low Pass Filter Frequency Response.

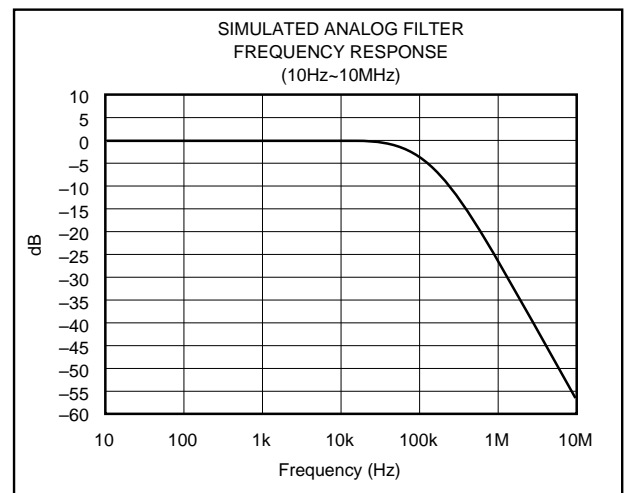

FIGURE 16. Low Pass Filter Frequency Response.

TEST CONDITIONS

Figure 18 illustrates the actual test conditions applied to PCM1710 in production. The 11th-order filter is necessary in the production environment for the removal of noise, resulting from the relatively long physical distance between the unit and the test analyzer. In most actual applications, the third-order filter shown in Figure 17 is adequate. Under normal conditions, THD+N typical performance is -70dB with a 30kHz low pass filter (shown here on the THD meter), improving to -92dB when the external 20kHz second-order filter is used.

EVALUATION FIXTURES

Two different evaluation fixtures are available for PCM1710.

DEM-PCM1710

This evaluation fixture is primarily intended for quick evaluation of the PCM1710's performance. DEM-PCM1710 can accept either an external clock or a user-installed crystal

oscillator. All of the functions can be controlled by on-board switches. DEM-PCM1710 does not contain a receiver chip or an external low pass filter. DEM-PCM1710 requires a single $+5\text{V}$ power supply.

DEM-DAI1710

This fixture is more complete than DEM-PCM1710; it includes a Digital Audio Interface (DAI) receiver chip for easy use and to provide a low-jitter 256fs system clock to the PCM1710. Also included are dual second-order low pass filters using Burr-Brown's OPA2604 dual FET-input op amp. The output of the DEM-DAI1710 is 2V_{rms} , using standard BNC-type connectors.

All of the functions of PCM1710 can be evaluated by using the DEM-DAI1710 jumper selections. DEM-DAI1710 requires $+5\text{V}$ and $\pm 5\text{V}$ to $\pm 15\text{V}$ power supplies. The schematic diagram for DEM-DAI1710 is shown in Figure 19. For more detailed information on the evaluation fixtures, contact your local Burr-Brown representative.

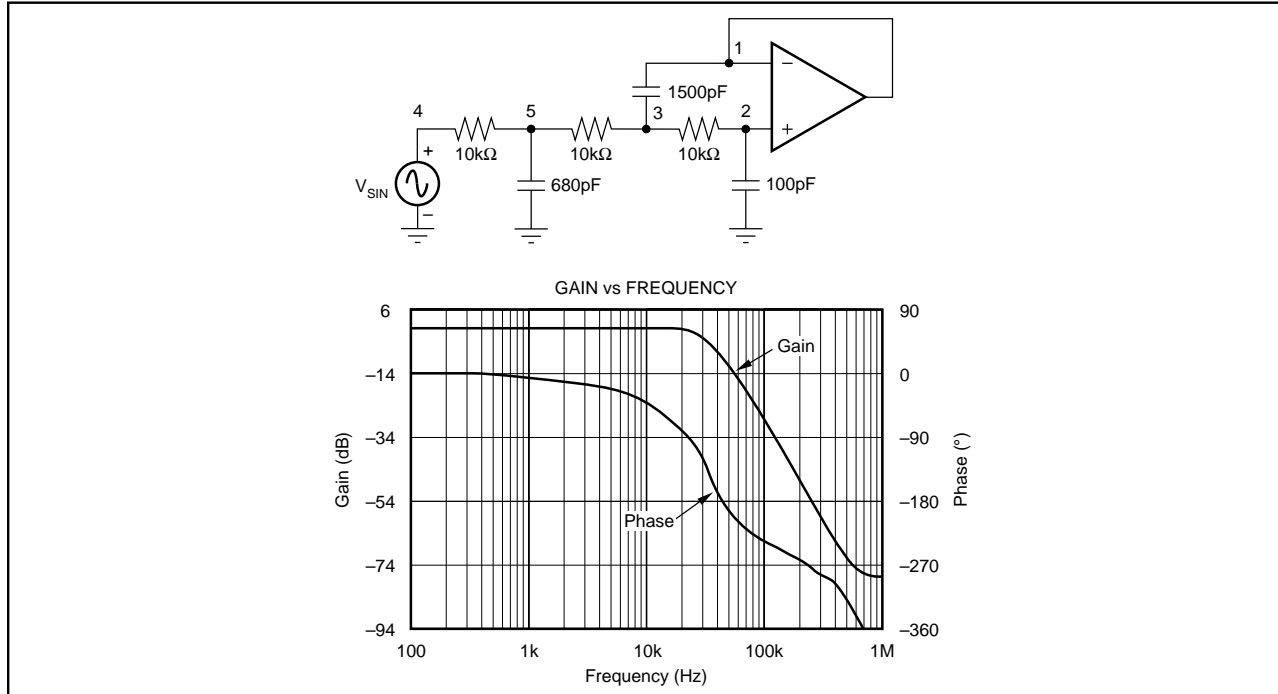

FIGURE 17. 3rd-Order LPF.

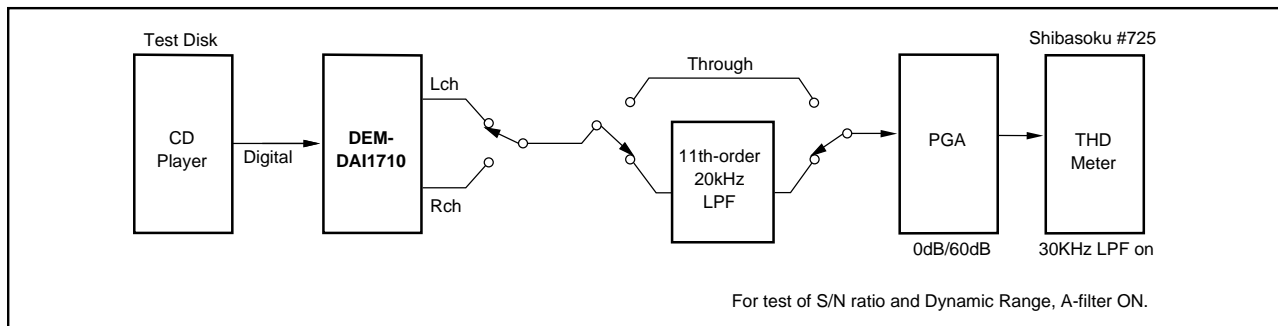

FIGURE 18. Test Block Diagram.

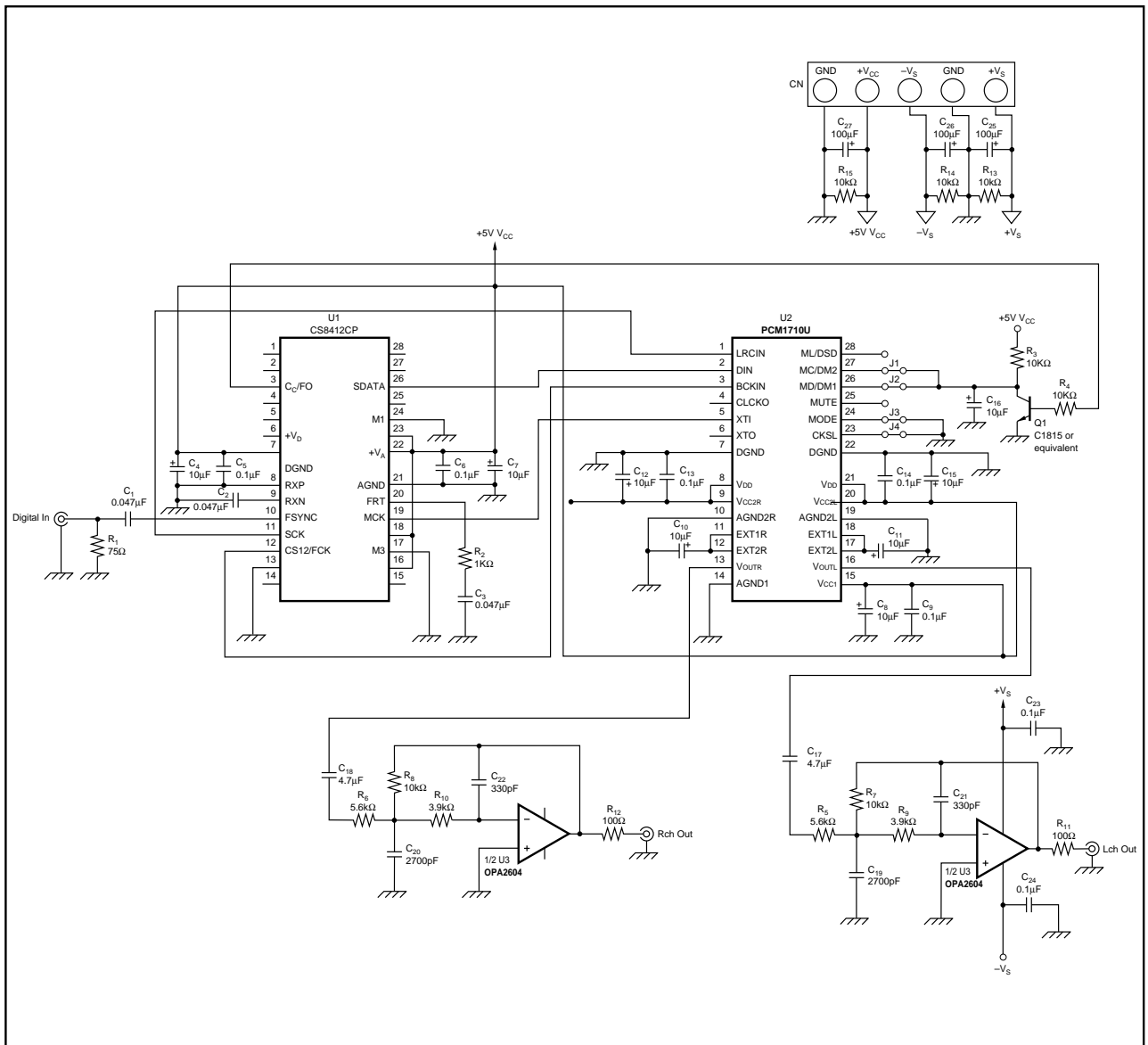

FIGURE 19. DEM-DAI1710 Schematic Circuit Diagram.

IMPORTANT NOTICE

Texas Instruments and its subsidiaries (TI) reserve the right to make changes to their products or to discontinue any product or service without notice, and advise customers to obtain the latest version of relevant information to verify, before placing orders, that information being relied on is current and complete. All products are sold subject to the terms and conditions of sale supplied at the time of order acknowledgment, including those pertaining to warranty, patent infringement, and limitation of liability.

TI warrants performance of its semiconductor products to the specifications applicable at the time of sale in accordance with TI's standard warranty. Testing and other quality control techniques are utilized to the extent TI deems necessary to support this warranty. Specific testing of all parameters of each device is not necessarily performed, except those mandated by government requirements.

Customers are responsible for their applications using TI components.

In order to minimize risks associated with the customer's applications, adequate design and operating safeguards must be provided by the customer to minimize inherent or procedural hazards.

TI assumes no liability for applications assistance or customer product design. TI does not warrant or represent that any license, either express or implied, is granted under any patent right, copyright, mask work right, or other intellectual property right of TI covering or relating to any combination, machine, or process in which such semiconductor products or services might be or are used. TI's publication of information regarding any third party's products or services does not constitute TI's approval, warranty or endorsement thereof.

This datasheet has been download from:

www.datasheetcatalog.com

Datasheets for electronics components.