

DATA SHEET

TDA7010T FM radio circuit

Product specification
File under Integrated Circuits, IC01

September 1983

FM radio circuit**TDA7010T****GENERAL DESCRIPTION**

The TDA7010T is a monolithic integrated circuit for mono FM portable radios, where a minimum on peripheral components is important (small dimensions and low costs).

The IC has an FLL (Frequency-Locked-Loop) system with an intermediate frequency of 70 kHz. The i.f. selectivity is obtained by active RC filters. The only function which needs alignment is the resonant circuit for the oscillator, thus selecting the reception frequency. Spurious reception is avoided by means of a mute circuit, which also eliminates too noisy input signals. Special precautions are taken to meet the radiation requirements.

The TDA7010T includes the following functions:

- R.F. input stage
- Mixer
- Local oscillator
- I.F. amplifier/limiter
- Phase demodulator
- Mute detector
- Mute switch

QUICK REFERENCE DATA

Supply voltage range (pin 4)	V_P	2,7 to 10 V
Supply current at $V_P = 4,5$ V	I_P	typ. 8 mA
R.F. input frequency range	f_{if}	1,5 to 110 MHz
Sensitivity for -3 dB limiting (e.m.f. voltage) (source impedance: 75 Ω ; mute disabled)	EMF	typ. 1,5 μ V
Signal handling (e.m.f. voltage) (source impedance: 75 Ω)	EMF	typ. 200 mV
A.F. output voltage at $R_L = 22$ k Ω	V_o	typ. 75 mV

PACKAGE OUTLINE

16-lead mini-pack; plastic (SO16; SOT109A); SOT109-1; 1996 July 24.

FM radio circuit

TDA7010T

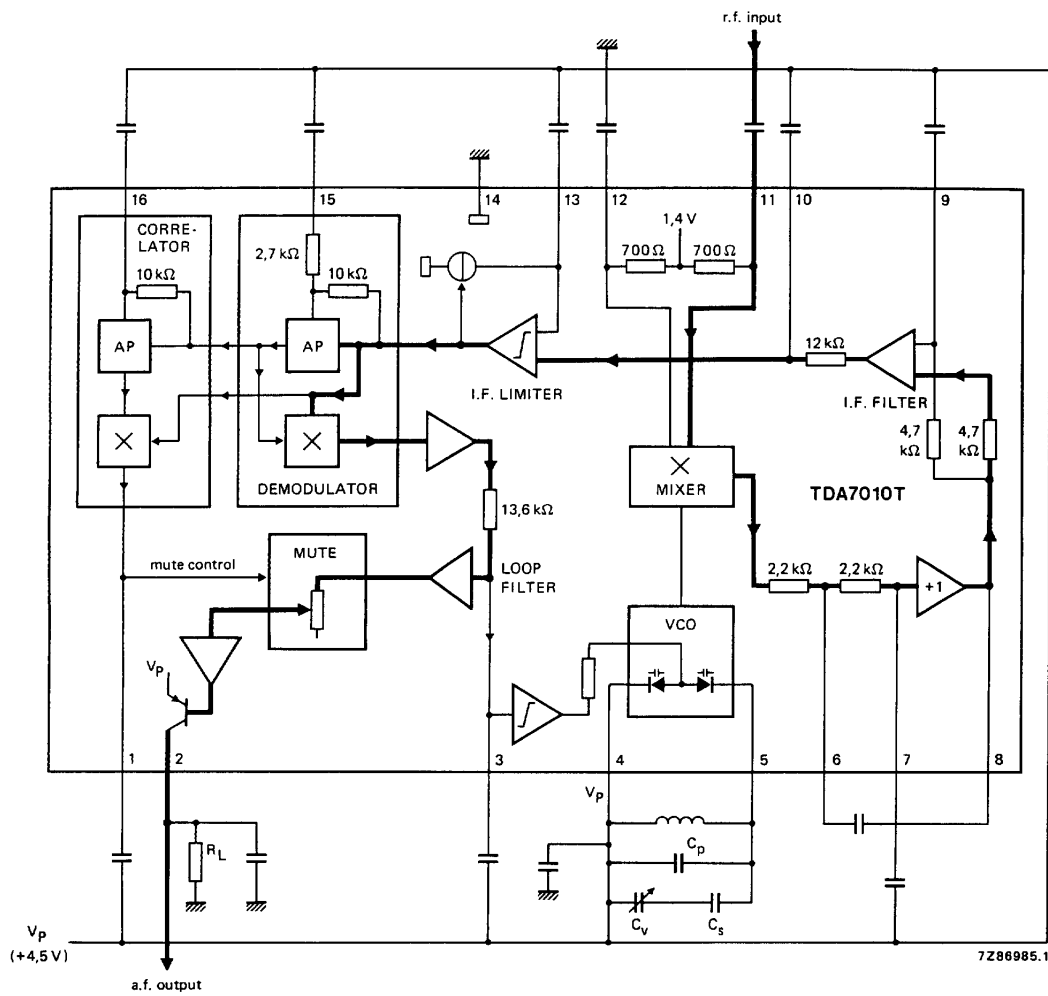

Fig.1 Block diagram.

FM radio circuit

TDA7010T

RATINGS

Limiting values in accordance with the Absolute Maximum System (IEC 134)

Supply voltage (pin 4)	V_P	max.	12 V
Oscillator voltage (pin 5)	V_{6-5}	$V_P - 0,5$ to $V_P + 0,5$ V	
Total power dissipation			see derating curve Fig.2
Storage temperature range	T_{stg}		-55 to + 150 °C
Operating ambient temperature range	T_{amb}		0 to + 60 °C

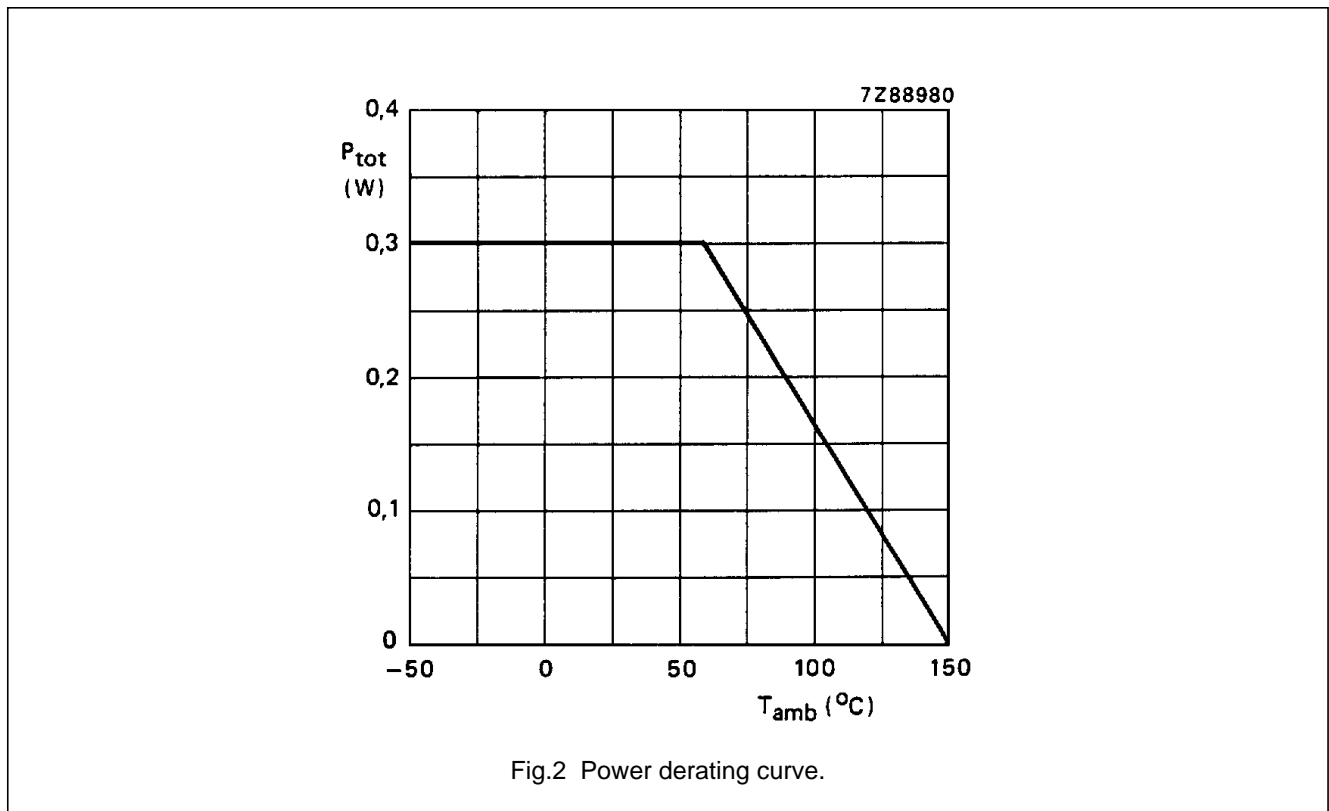

Fig.2 Power derating curve.

D.C. CHARACTERISTICS

$V_P = 4,5$ V; $T_{amb} 25$ °C; measured in Fig.4; unless otherwise specified

PARAMETER	SYMBOL	MIN.	TYP.	MAX.	UNIT
Supply voltage (pin 4)	V_P	2,7	4,5	10	V
Supply current at $V_P = 4,5$ V	I_P	—	8	—	mA
Oscillator current (pin 5)	I_5	—	280	—	μ A
Voltage at pin 12	V_{12-14}	—	1,35	—	V
Output current at pin 2	I_2	—	60	—	μ A
Voltage at pin 2; $R_L = 22$ k Ω	V_{2-14}	—	1,3	—	V

FM radio circuit

TDA7010T

A.C. CHARACTERISTICS

$V_p = 4,5$ V; $T_{amb} = 25$ °C; measured in Fig.4 (mute switch open, enabled); $f_{rf} = 96$ MHz (tuned to max. signal at 5μ V e.m.f.) modulated with $\Delta f = \pm 22,5$ kHz; $f_m = 1$ kHz; EMF = 0,2 mV (e.m.f. voltage at a source impedance of 75 Ω); r.m.s. noise voltage measured unweighted ($f = 300$ Hz to 20 kHz); unless otherwise specified.

PARAMETER	SYMBOL	MIN.	TYP.	MAX.	UNIT
Sensitivity (see Fig.3) (e.m.f. voltage) for -3 dB limiting; muting disabled	EMF	-	1,5	-	μ V
for -3 dB muting	EMF	-	6	-	μ V
for S/N = 26 dB	EMF	-	5,5	-	μ V
Signal handling (e.m.f. voltage) for THD < 10%; $\Delta f = \pm 75$ kHz	EMF	-	200	-	mV
Signal-to-noise ratio	S/N	-	60	-	dB
Total harmonic distortion at $\Delta f = \pm 22,5$ kHz	THD	-	0,7	-	%
at $\Delta f = \pm 75$ kHz	THD	-	2,3	-	%
AM suppression of output voltage (ratio of the AM output signal referred to the FM output signal) FM signal: $f_m = 1$ kHz; $\Delta f = \pm 75$ kHz AM signal: $f_m = 1$ kHz; $m = 80\%$	AMS	-	50	-	dB
Ripple rejection ($\Delta V_p = 100$ mV; $f = 1$ kHz)	RR	-	10	-	dB
Oscillator voltage (r.m.s. value) at pin 5	$V_{5-4(rms)}$	-	250	-	mV
Variation of oscillator frequency with supply voltage ($\Delta V_p = 1$ V)	Δf_{osc}	-	60	-	kHz/V
Selectivity	S_{+300}	-	43	-	dB
	S_{-300}	-	28	-	dB
A.F.C. range	Δf_{rf}	-	± 300	-	kHz
Audio bandwidth at $\Delta V_o = 3$ dB measured with pre-emphasis ($t = 50 \mu$ s)	B	-	10	-	kHz
A.F. output voltage (r.m.s. value) at $R_L = 22$ k Ω	$V_{o(rms)}$	-	75	-	mV
Load resistance at $V_p = 4,5$ V	R_L	-	-	22	k Ω
at $V_p = 9,0$ V	R_L	-	-	47	k Ω

FM radio circuit

TDA7010T

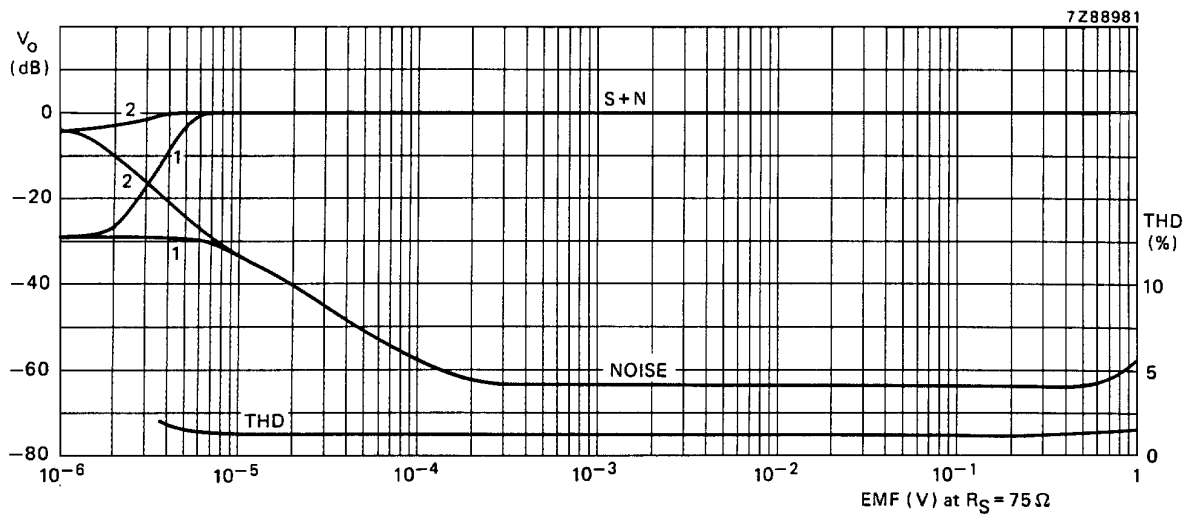

Fig.3 A.F. output voltage (V_o) and total harmonic distortion (THD) as a function of the e.m.f. input voltage (EMF) with a source impedance (R_S) of 75Ω : (1) muting system enabled; (2) muting system disabled.

Conditions: 0 dB = 75 mV; $f_r = 96$ MHz.
 for S + N curve: $\Delta f = \pm 22,5$ kHz; $f_m = 1$ kHz.
 for THD curve: $\Delta f = \pm 75$ kHz; $f_m = 1$ kHz.

Note

1. The muting system can be disabled by feeding a current of about $20 \mu A$ into pin 1.

FM radio circuit

TDA7010T

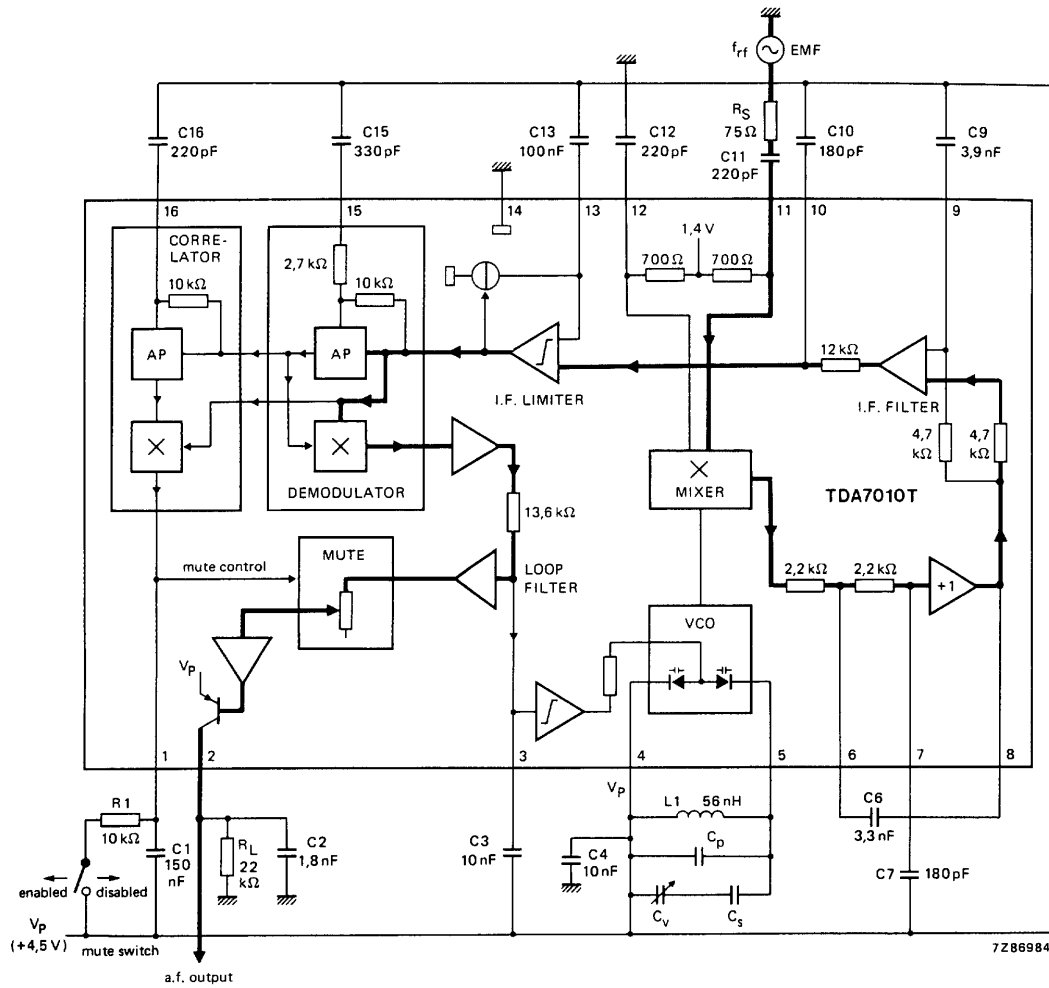
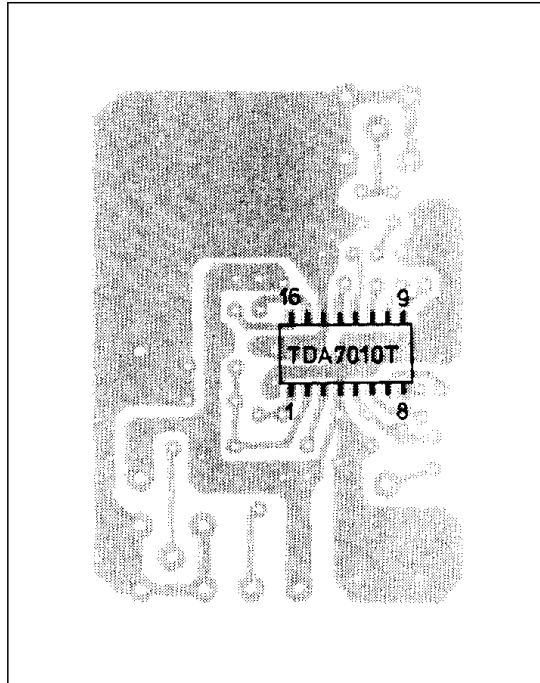

Fig.4 Test circuit; for printed-circuit boards see Figs 5 and 6.

FM radio circuit

TDA7010T



7Z86989.1

Fig.5 Track side of printed-circuit board used for the circuit of Fig.4.

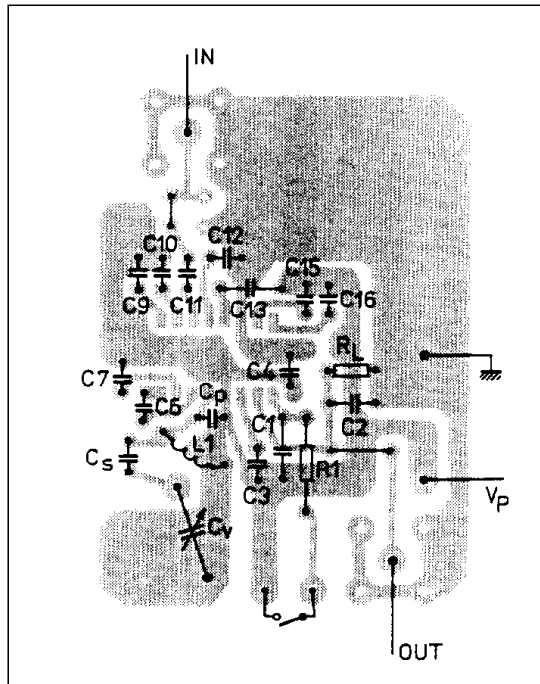

7Z86988.1

Fig.6 Component side of printed-circuit board showing component layout used for the circuit of Fig.4.

FM radio circuit

TDA7010T

PACKAGE OUTLINE

SO16: plastic small outline package; 16 leads; body width 3.9 mm

SOT109-1

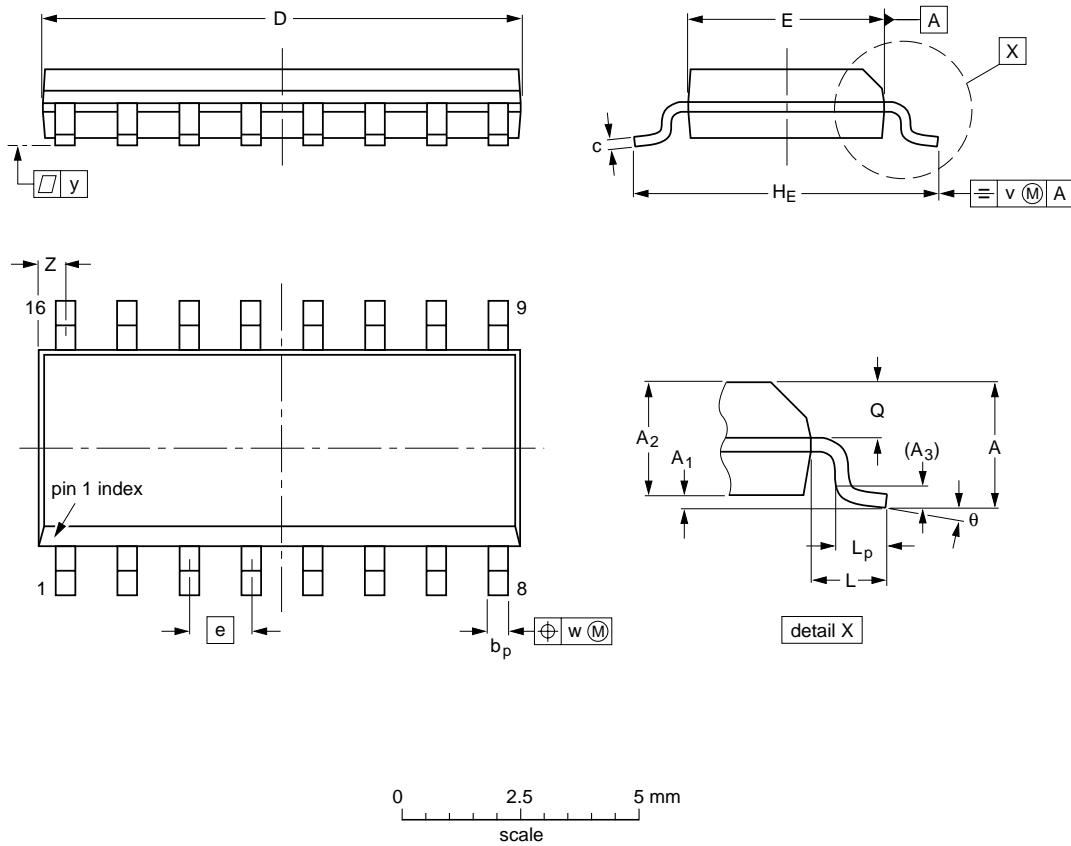

DIMENSIONS (inch dimensions are derived from the original mm dimensions)

UNIT	A max.	A ₁	A ₂	A ₃	b _p	c	D ⁽¹⁾	E ⁽¹⁾	e	H _E	L	L _p	Q	v	w	y	Z ⁽¹⁾	θ
mm	1.75	0.25 0.10	1.45 1.25	0.25	0.49 0.36	0.25 0.19	10.0 9.8	4.0 3.8	1.27	6.2 5.8	1.05	1.0 0.4	0.7 0.6	0.25	0.25	0.1	0.7 0.3	8° 0°
inches	0.069	0.010 0.004	0.057 0.049	0.01	0.019 0.014	0.0100 0.0075	0.39 0.38	0.16 0.15	0.050	0.244 0.228	0.041	0.039 0.016	0.028 0.020	0.01	0.01	0.004	0.028 0.012	

Note

1. Plastic or metal protrusions of 0.15 mm maximum per side are not included.

OUTLINE VERSION	REFERENCES				EUROPEAN PROJECTION	ISSUE DATE
	IEC	JEDEC	EIAJ			
SOT109-1	076E07S	MS-012AC				95-01-23 97-05-22

FM radio circuit

TDA7010T

SOLDERING

Introduction

There is no soldering method that is ideal for all IC packages. Wave soldering is often preferred when through-hole and surface mounted components are mixed on one printed-circuit board. However, wave soldering is not always suitable for surface mounted ICs, or for printed-circuits with high population densities. In these situations reflow soldering is often used.

This text gives a very brief insight to a complex technology. A more in-depth account of soldering ICs can be found in our *"IC Package Databook"* (order code 9398 652 90011).

Reflow soldering

Reflow soldering techniques are suitable for all SO packages.

Reflow soldering requires solder paste (a suspension of fine solder particles, flux and binding agent) to be applied to the printed-circuit board by screen printing, stencilling or pressure-syringe dispensing before package placement.

Several techniques exist for reflowing; for example, thermal conduction by heated belt. Dwell times vary between 50 and 300 seconds depending on heating method. Typical reflow temperatures range from 215 to 250 °C.

Preheating is necessary to dry the paste and evaporate the binding agent. Preheating duration: 45 minutes at 45 °C.

Wave soldering

Wave soldering techniques can be used for all SO packages if the following conditions are observed:

- A double-wave (a turbulent wave with high upward pressure followed by a smooth laminar wave) soldering technique should be used.
- The longitudinal axis of the package footprint must be parallel to the solder flow.
- The package footprint must incorporate solder thieves at the downstream end.

During placement and before soldering, the package must be fixed with a droplet of adhesive. The adhesive can be applied by screen printing, pin transfer or syringe dispensing. The package can be soldered after the adhesive is cured.

Maximum permissible solder temperature is 260 °C, and maximum duration of package immersion in solder is 10 seconds, if cooled to less than 150 °C within 6 seconds. Typical dwell time is 4 seconds at 250 °C.

A mildly-activated flux will eliminate the need for removal of corrosive residues in most applications.

Repairing soldered joints

Fix the component by first soldering two diagonally-opposite end leads. Use only a low voltage soldering iron (less than 24 V) applied to the flat part of the lead. Contact time must be limited to 10 seconds at up to 300 °C. When using a dedicated tool, all other leads can be soldered in one operation within 2 to 5 seconds between 270 and 320 °C.

FM radio circuit

TDA7010T

DEFINITIONS

Data sheet status	
Objective specification	This data sheet contains target or goal specifications for product development.
Preliminary specification	This data sheet contains preliminary data; supplementary data may be published later.
Product specification	This data sheet contains final product specifications.
Limiting values	
Limiting values given are in accordance with the Absolute Maximum Rating System (IEC 134). Stress above one or more of the limiting values may cause permanent damage to the device. These are stress ratings only and operation of the device at these or at any other conditions above those given in the Characteristics sections of the specification is not implied. Exposure to limiting values for extended periods may affect device reliability.	
Application information	
Where application information is given, it is advisory and does not form part of the specification.	

LIFE SUPPORT APPLICATIONS

These products are not designed for use in life support appliances, devices, or systems where malfunction of these products can reasonably be expected to result in personal injury. Philips customers using or selling these products for use in such applications do so at their own risk and agree to fully indemnify Philips for any damages resulting from such improper use or sale.

This datasheet has been download from:

www.datasheetcatalog.com

Datasheets for electronics components.