

DATA SHEET

TDA1553CQ

**2 × 22 W stereo BTL car radio
power amplifier with loudspeaker
protection and 3-state mode switch**

Product specification
Supersedes data of July 1994
File under Integrated Circuits, IC01

1995 Dec 15

2 × 22 W stereo BTL car radio power amplifier with loudspeaker protection and 3-state mode switch

TDA1553CQ

FEATURES

- Few peripheral components
- High output power
- Low output offset voltage
- Fixed gain
- Loudspeaker protection
- Good ripple rejection
- 3-state mode switch (operating, mute, standby)
- Load dump protection
- AC and DC short-circuit safe to ground and to V_P
- Thermally protected
- Reverse polarity safe

- High energy handling capability at the outputs ($V_P = 0$)
- Electrostatic discharge protection
- No switch-on/switch-off pop
- Flexible leads
- Low thermal resistance.

GENERAL DESCRIPTION

The TDA1553CQ is a monolithic integrated class-B output amplifier in a 13-lead plastic DIL-bent-SIL power package. It contains 2 × 22 W amplifiers in BTL configuration.

The device is primarily developed for car radio applications.

QUICK REFERENCE DATA

SYMBOL	PARAMETER	CONDITIONS	MIN.	TYP.	MAX.	UNIT
V_P	positive supply voltage					
	operating		6	14.4	18	V
	non-operating		–	–	30	V
	load dump		–	–	45	V
I_{ORM}	repetitive peak output current		–	–	4	A
I_q	total quiescent current		–	80	–	mA
I_{stb}	standby current		–	40	100	μ A
$ Z_i $	input impedance		50	–	–	k Ω
T_{vj}	virtual junction temperature		–	–	150	$^{\circ}$ C
Stereo application						
P_O	output power	at 4 Ω ; THD = 10%	–	22	–	W
SVRR	supply voltage ripple rejection	$R_s = 0 \Omega$; $f = 100 \text{ Hz to } 10 \text{ kHz}$	48	–	–	dB
$ \Delta V_O $	DC output offset voltage		–	–	150	mV
α_{cs}	channel separation		40	–	–	dB
$ \Delta G_v $	channel unbalance		–	–	1	dB

ORDERING INFORMATION

TYPE NUMBER	PACKAGE		
	NAME	DESCRIPTION	VERSION
TDA1553CQ	DBS13P	plastic DIL-bent-SIL power package; 13 leads (lead length 12 mm)	SOT141-6

2 × 22 W stereo BTL car radio power amplifier with
loudspeaker protection and 3-state mode switch

TDA1553CQ

BLOCK DIAGRAM

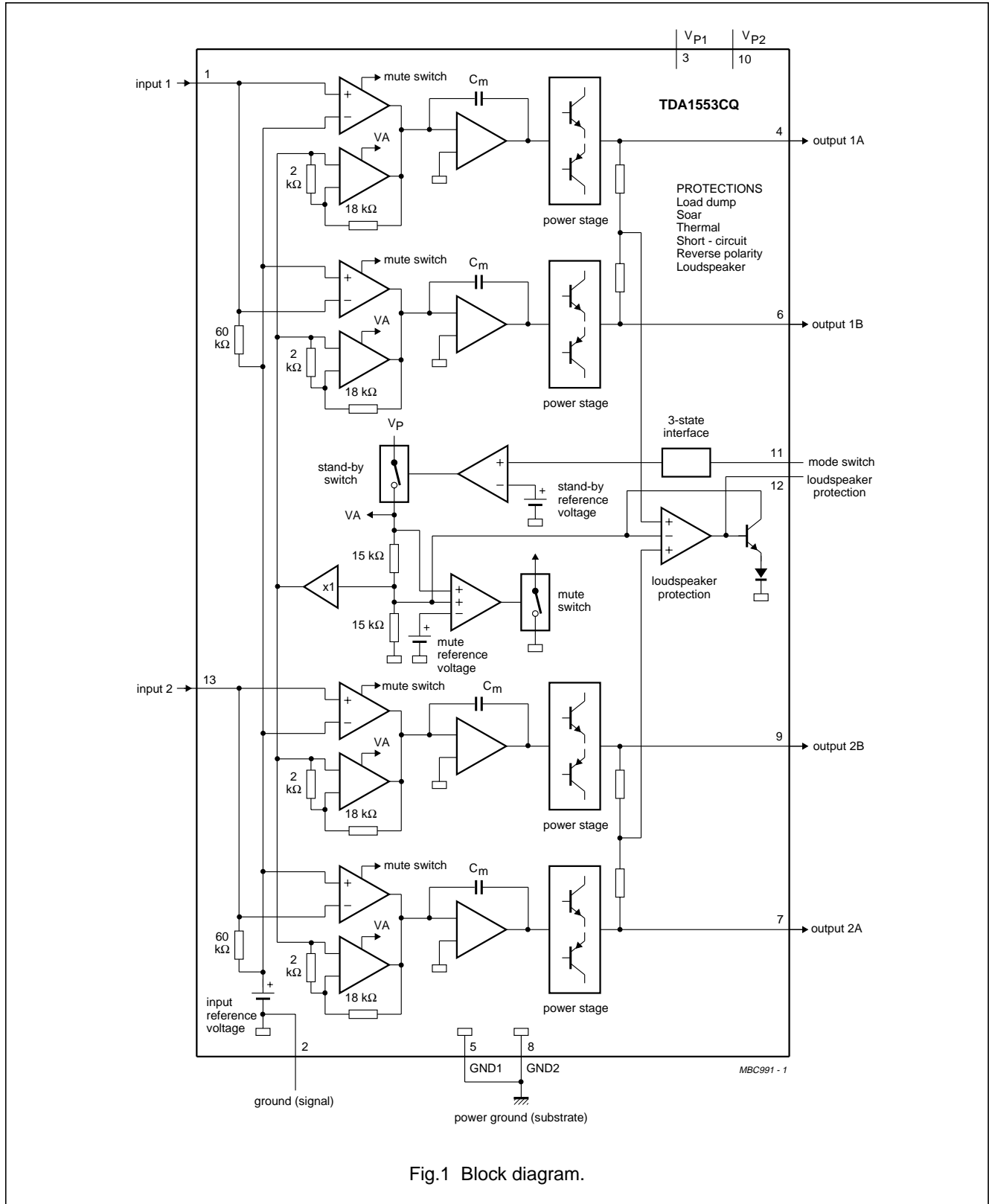

Fig.1 Block diagram.

2 × 22 W stereo BTL car radio power amplifier with loudspeaker protection and 3-state mode switch

TDA1553CQ

PINNING

SYMBOL	PIN	DESCRIPTION
IN1	1	input 1
GND(S)	2	signal ground
V _{P1}	3	supply voltage
OUT1A	4	output 1A
GND1	5	power ground 1
OUT1B	6	output 1B
OUT2A	7	output 2A
GND2	8	power ground 2
OUT2B	9	output 2B
V _{P2}	10	supply voltage
MODE	11	mode switch input
LSP	12	loudspeaker protection
IN2	13	input 2

FUNCTIONAL DESCRIPTION

The TDA1553CQ contains two identical amplifiers with differential input stages and can be used for bridge applications. The gain of each amplifier is fixed at 26 dB. Special features of the device are:

3-state mode switch

- standby: low supply current (<100 µA)
- mute: input signal suppressed
- operating: normal on condition.

Loudspeaker protection

When a short-circuit to ground occurs, which forces a DC voltage across the loudspeaker of ≥ 1 V, a built-in protection circuit becomes active and limits the DC voltage across the loudspeaker to ≤ 1 V.

Pin 12 detects the status of the protection circuit (e.g. for diagnostic purposes).

Short-circuit protection

If any output is short-circuited to ground during the standby mode, it becomes impossible to switch the circuit to the mute or operating condition. In this event the supply current will be limited to a few milliamps.

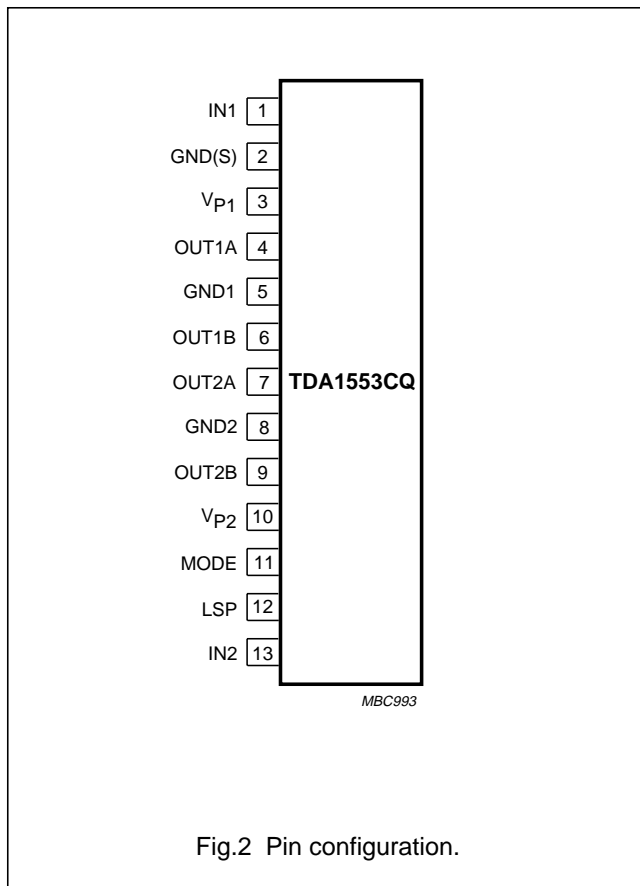

2 × 22 W stereo BTL car radio power amplifier with
loudspeaker protection and 3-state mode switch

TDA1553CQ

LIMITING VALUES

In accordance with the absolute maximum system (IEC 134).

SYMBOL	PARAMETER	CONDITION	MIN.	MAX.	UNIT
V _P	positive supply voltage				
	operating		–	18	V
	non-operating		–	30	V
	load dump protection	during 50 ms; t _r ≥ 2.5 ms	–	45	V
I _{OSM}	non-repetitive peak output current		–	6	A
I _{ORM}	repetitive peak output current		–	4	A
T _{stg}	storage temperature range		–55	+150	°C
T _{amb}	operating ambient temperature range		–40	+85	°C
T _{vj}	virtual junction temperature		–	150	°C
V _{psc}	AC and DC short-circuit safe voltage		–	18	V
	energy handling capability at outputs	V _P = 0	–	200	mJ
V _{pr}	reverse polarity		–	6	V
P _{tot}	total power dissipation		–	60	W

THERMAL CHARACTERISTICS

In accordance with IEC 747-1.

SYMBOL	PARAMETER	VALUE	UNIT
R _{th j-a}	thermal resistance from junction to ambient in free air	40	K/W
R _{th j-c}	thermal resistance from junction to case (see Fig.3)	1.5	K/W

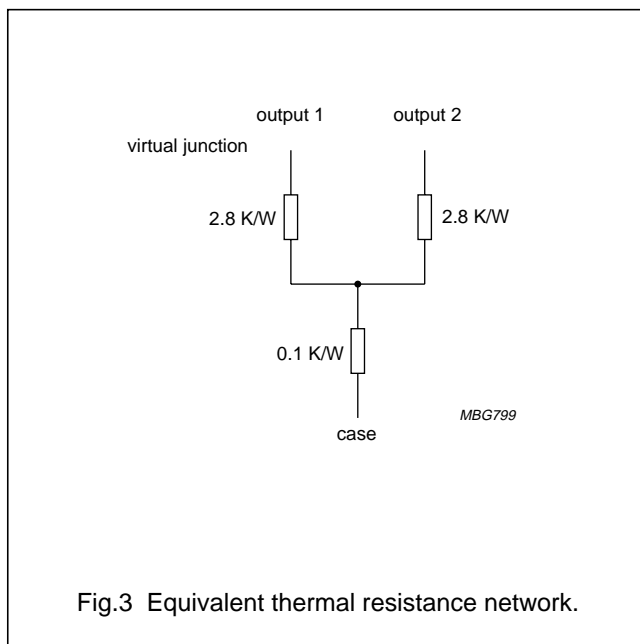

Fig.3 Equivalent thermal resistance network.

2 × 22 W stereo BTL car radio power amplifier with loudspeaker protection and 3-state mode switch

TDA1553CQ

DC CHARACTERISTICS

$V_P = 14.4\text{ V}$; $T_{\text{amb}} = 25\text{ °C}$; measured in Fig.4; unless otherwise specified.

SYMBOL	PARAMETER	CONDITIONS	MIN.	TYP.	MAX.	UNIT
Supply						
V_P	positive supply voltage	note 1	6	14.4	18	V
I_q	quiescent current	$R_L = \infty$	–	80	160	mA
		note 2	–	5.5	–	mA
Operating condition						
V_{11}	mode switch voltage level		2.2	–	7	V
I_{11}	mode switch current	$V_{11} = 2.2\text{ V}$	–	50	100	μA
V_O	DC output voltage	note 3	–	6.9	–	V
$ \Delta V_O $	DC output offset voltage		–	–	150	mV
Mute condition						
V_{11}	mode switch voltage level		0	–	0.6	V
I_{11}	mode switch current	$V_{11} = 0.6\text{ V}$	–	50	100	μA
V_O	DC output voltage	note 3	–	6.9	–	V
$ \Delta V_O $	DC output offset voltage		–	–	150	mV
standby condition						
$ I_{11} $	mode switch 3-state leakage current		–	–	10	μA
I_{stb}	standby current	$I_{11} = 0\text{ }\mu\text{A}$	–	40	100	μA
Loudspeaker protection						
$ \Delta V_{4-6} $ or $ \Delta V_{7-9} $	DC voltage across R_L		–	–	1	V
Protection active (ΔV_{4-6} or $\Delta V_{7-9} \geq 1.0\text{ V}$)						
I_{12}	current information		–	25	–	μA
V_{12}	voltage information		3.6	–	–	V
Protection not active (ΔV_{4-6} and $\Delta V_{7-9} \leq 0.15\text{ V}$)						
V_{12}	voltage information		–	–	0.3	V

Notes

1. The circuit is DC adjusted at $V_P = 6$ to 18 V and AC operating at $V_P = 9$ to 18 V .
2. If any output is short-circuited to ground during the standby mode and in this condition the circuit is switched to mute or operating condition.
3. At $18\text{ V} < V_P < 30\text{ V}$ the DC output voltage $\leq V_P/2$.

2 × 22 W stereo BTL car radio power amplifier with loudspeaker protection and 3-state mode switch

TDA1553CQ

AC CHARACTERISTICS

$V_P = 14.4\text{ V}$; $R_L = 4\ \Omega$; $f = 1\text{ kHz}$; $T_{\text{amb}} = 25\text{ °C}$; measured in Fig.4; unless otherwise specified.

SYMBOL	PARAMETER	CONDITIONS	MIN.	TYP.	MAX.	UNIT	
P_O	output power	$V_P = 14.4\text{ V}$					
		THD = 0.5%	15	17	–	W	
		THD = 10%	20	22	–	W	
THD	total harmonic distortion	$P_O = 1\text{ W}$	–	0.1	–	%	
P_O	output power	$V_P = 13.2\text{ V}$					
		THD = 0.5%	–	12	–	W	
		THD = 10%	–	17	–	W	
B	power bandwidth	THD = 0.5%; $P_O = -1\text{ dB}$; with respect to 15 W	–	20 to 15 000	–	Hz	
f_l	low frequency roll-off	at -1 dB ; note 1	–	25	–	Hz	
f_h	high frequency roll-off	at -1 dB	20	–	–	kHz	
G_v	closed loop voltage gain		25	26	27	dB	
SVRR	supply voltage ripple rejection	note 2					
			on	48	–	–	dB
			mute	48	–	–	dB
			standby	80	–	–	dB
$ Z_i $	input impedance		50	60	75	k Ω	
V_{no}	noise output voltage	note 3					
			on	–	70	120	μV
			on	–	100	–	μV
V_{no}	noise output voltage	notes 3 and 4	–	60	–	μV	
α_{cs}	channel separation	$R_S = 10\text{ k}\Omega$	40	–	–	dB	
$ \Delta G_v $	channel unbalance		–	–	1	dB	
V_O	output voltage in mute	note 5	–	–	2	mV	

Notes

- Frequency response externally fixed.
- Ripple rejection measured at the output with a source-impedance of $0\ \Omega$, maximum ripple amplitude of 2 V (p-p) and at a frequency between 100 Hz and 10 kHz.
- Noise measured in a bandwidth of 20 Hz to 20 kHz.
- Noise output voltage independent of R_S ($V_I = 0\text{ V}$).
- $V_I = V_{I\text{max}} = 1\text{ V RMS}$.

2 × 22 W stereo BTL car radio power amplifier with
loudspeaker protection and 3-state mode switch

TDA1553CQ

APPLICATION INFORMATION

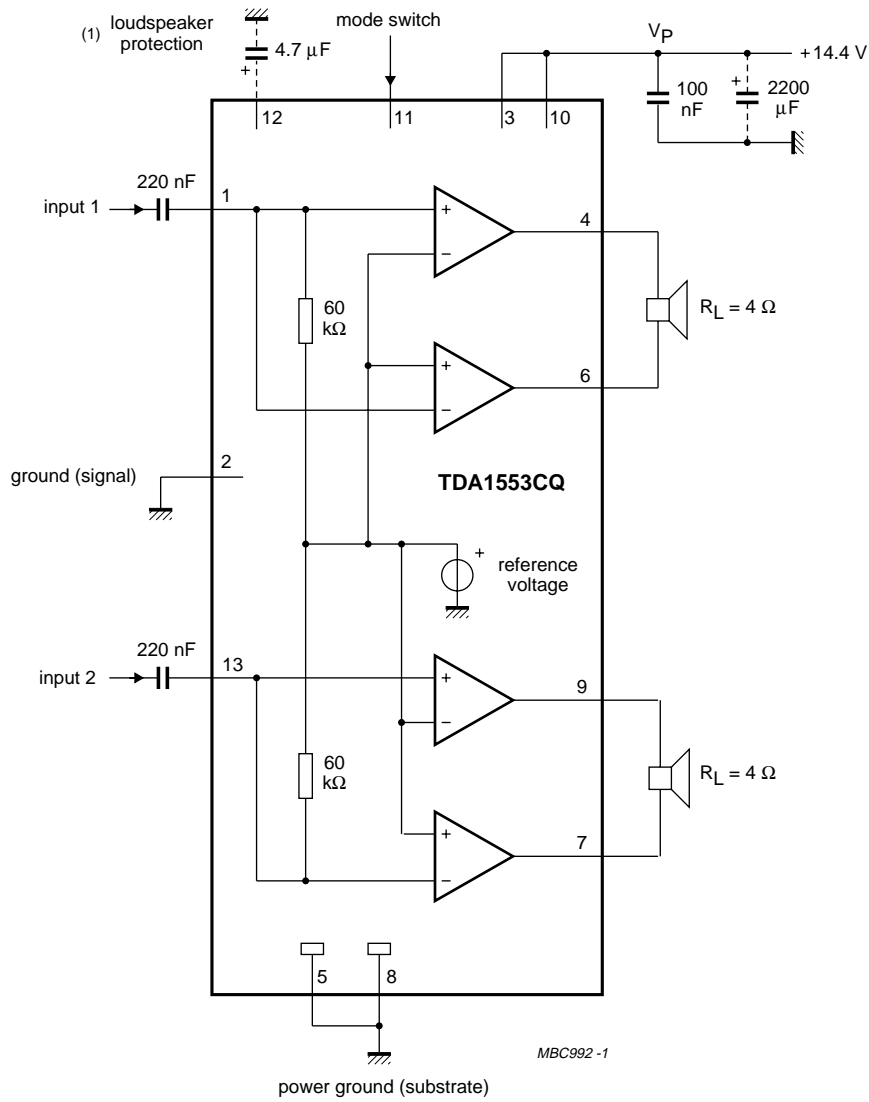

(1) With C = 4.7 μF the delay time of the loudspeaker protection is typically 0.5 s.

Fig.4 Stereo BTL application diagram.

2 × 22 W stereo BTL car radio power amplifier with
loudspeaker protection and 3-state mode switch

TDA1553CQ

PACKAGE OUTLINE

DBS13P: plastic DIL-bent-SIL power package; 13 leads (lead length 12 mm)

SOT141-6

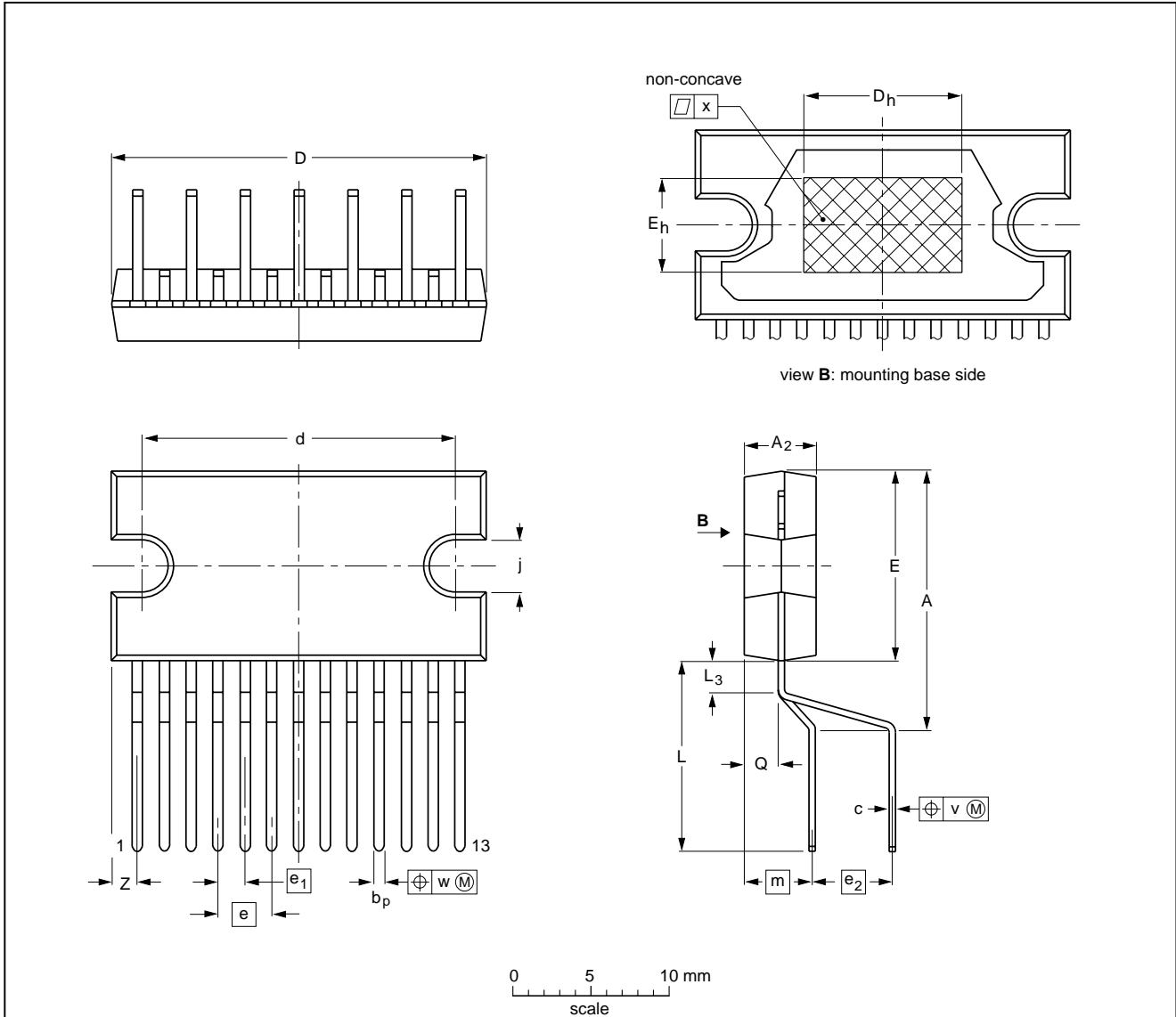

DIMENSIONS (mm are the original dimensions)

UNIT	A	A ₂	b _p	c	D ⁽¹⁾	d	D _h	E ⁽¹⁾	e	e ₁	e ₂	E _h	j	L	L ₃	m	Q	v	w	x	Z ⁽¹⁾
mm	17.0 15.5	4.6 4.2	0.75 0.60	0.48 0.38	24.0 23.6	20.0 19.6	10	12.2 11.8	3.4	1.7	5.08	6	3.4 3.1	12.4 11.0	2.4 1.6	4.3	2.1 1.8	0.8	0.25	0.03	2.00 1.45

Note

1. Plastic or metal protrusions of 0.25 mm maximum per side are not included.

OUTLINE VERSION	REFERENCES				EUROPEAN PROJECTION	ISSUE DATE
	IEC	JEDEC	EIAJ			
SOT141-6						95-03-11 97-12-16

2 × 22 W stereo BTL car radio power amplifier with loudspeaker protection and 3-state mode switch

TDA1553CQ

SOLDERING

Introduction

There is no soldering method that is ideal for all IC packages. Wave soldering is often preferred when through-hole and surface mounted components are mixed on one printed-circuit board. However, wave soldering is not always suitable for surface mounted ICs, or for printed-circuits with high population densities. In these situations reflow soldering is often used.

This text gives a very brief insight to a complex technology. A more in-depth account of soldering ICs can be found in our "IC Package Databook" (order code 9398 652 90011).

Soldering by dipping or by wave

The maximum permissible temperature of the solder is 260 °C; solder at this temperature must not be in contact with the joint for more than 5 seconds. The total contact time of successive solder waves must not exceed 5 seconds.

The device may be mounted up to the seating plane, but the temperature of the plastic body must not exceed the specified maximum storage temperature ($T_{stg\ max}$). If the printed-circuit board has been pre-heated, forced cooling may be necessary immediately after soldering to keep the temperature within the permissible limit.

Repairing soldered joints

Apply a low voltage soldering iron (less than 24 V) to the lead(s) of the package, below the seating plane or not more than 2 mm above it. If the temperature of the soldering iron bit is less than 300 °C it may remain in contact for up to 10 seconds. If the bit temperature is between 300 and 400 °C, contact may be up to 5 seconds.

DEFINITIONS

Data sheet status	
Objective specification	This data sheet contains target or goal specifications for product development.
Preliminary specification	This data sheet contains preliminary data; supplementary data may be published later.
Product specification	This data sheet contains final product specifications.
Limiting values	
Limiting values given are in accordance with the Absolute Maximum Rating System (IEC 134). Stress above one or more of the limiting values may cause permanent damage to the device. These are stress ratings only and operation of the device at these or at any other conditions above those given in the Characteristics sections of the specification is not implied. Exposure to limiting values for extended periods may affect device reliability.	
Application information	
Where application information is given, it is advisory and does not form part of the specification.	

LIFE SUPPORT APPLICATIONS

These products are not designed for use in life support appliances, devices, or systems where malfunction of these products can reasonably be expected to result in personal injury. Philips customers using or selling these products for use in such applications do so at their own risk and agree to fully indemnify Philips for any damages resulting from such improper use or sale.

This datasheet has been download from:

www.datasheetcatalog.com

Datasheets for electronics components.