

V-F/F-V CONVERTOR

■ GENERAL DESCRIPTION

The NJM4151 provide a simple low-cost method of A/D conversion. They have all the inherent advantages of the voltage-to-frequency conversion technique. The Output of NJM4151 is a series of pulses of constant duration. The frequency of the pulses is proportional to the applied input voltage. These converters are designed for use in a wide range of data conversion and remote sensing applications.

■ FEATURES

- Operating Voltage (8V~22V)
- Frequency Operation from (1.0Hz to 100kHz)
- Package Outline DIP8, DMP8
- Bipolar Technology

■ PACKAGE OUTLINE

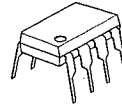

NJM 4151 D



NJM 4151 M

■ PIN CONFIGURATION

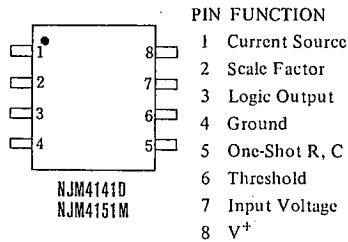

■ EQUIVALENT CIRCUIT

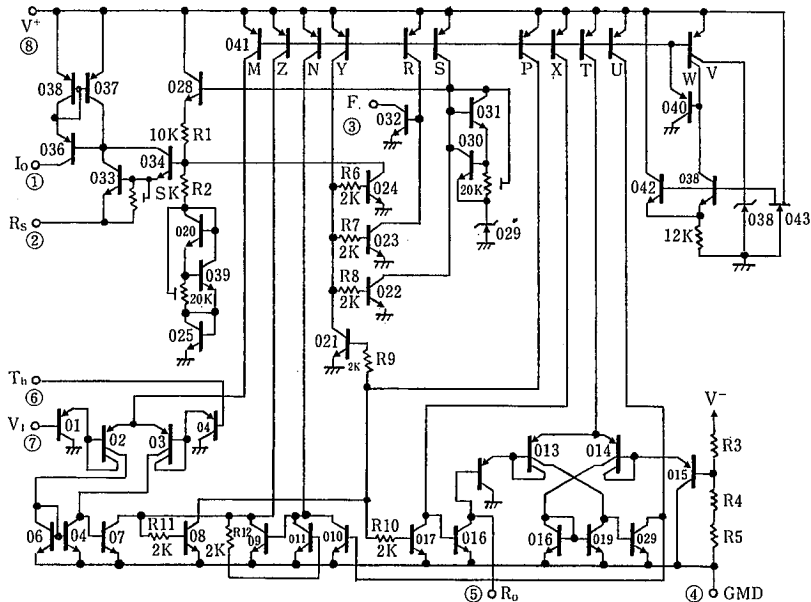

■ ABSOLUTE MAXIMUM RATINGS

(Ta=25°C)

PARAMETER	SYMBOL	RATINGS	UNIT
Supply Voltage	V ⁺	8 ~ 22	V
Output Sink Current	I _{SINK}	20	mA
Power Dissipation	P _D	(DIP8) 500	mW
		(DMP8) 300	mW
Input Voltage	V _I	-0.2 ~ V ⁺	(V)
Operating Temperature Range	T _{opr}	-40 ~ +85	°C
Storage Temperature Range	T _{stg}	-40 ~ +125	°C

■ ELECTRICAL CHARACTERISTICS

(V⁺=+15V, Ta=+25°C)

PARAMETER	TEST CONDITION	MIN.	TYP.	MAX.	UNIT
Operating Current	8V < V ⁺ < 15V	2.0	3.5	6.0	mA
	15V < V ⁺ < 22V	2.0	4.5	7.5	mA
Conversion Accuracy Scale Factor	V _{IN} =10V R _S =14.0kΩ	0.90	1.00	1.10	kHz/V
Drift with Temperature	V _{IN} =10V	—	±100	—	ppm/°C
Drift with V ⁺	V _{IN} =1.0V 8V < V ⁺ < 18V	—	0.2	1.0	%/V
Input Comparator Offset Voltage		—	5	10	mV
Offset Current		—	±50	±100	nA
Input Bias Current		—	-100	-300	nA
Common Mode Range(Note 1)		0 to V ⁺ -3	0 to V ⁺ -2	—	V
One-Shot Threshold Voltage, Pin 5		0.63	0.66	0.70	× V ⁺
Input Bias Current, Pin 5		—	-100	-500	nA
Reset V _{SAT}	Pin 5, I=2.2mA	—	0.15	0.50	V
Current Source Output Current (R _S =14.0kΩ)	Pin 1, V ⁺ =0V	—	138.7	—	μA
Change with Voltage	Pin 1, V ⁺ =0V to V ⁺ =10V	—	1.0	2.5	μA
Off Leakage	Pin 1, V ⁺ =0V	—	1	50.0	nA
Reference Voltage	Pin 2	1.70	1.90	2.08	V
Logic Output V _{SAT}	Pin 3, I=3.0mA	—	0.15	0.50	V
V _{SAT}	Pin 3, I=2.0mA	—	0.10	0.30	V
Off Leakage		—	0.1	1.0	μA

Note 1: Input Common Mode Range includes ground.

■ PRINCIPLE OF OPERATION

Single Supply Mode Voltage-to-Frequency Conversion

In this application the NJM4151 functions as a stand-alone voltage to frequency converter operating on a single positive power supply. Refer to Figure 1, the simplified block diagram. The NJM4151 contains a voltage comparator, a one-shot, and a precision switched current source. The voltage comparator compares a positive input voltage applied at pin 7 to the voltage at pin 6. If the input voltage is higher, the comparator will fire the one-shot. The output of the one-shot is connected to both the logic output and the precision switched current source. During the one-shot period, T , the logic output will go low and the current source will turn on with current I .

At the end of the one-shot period the logic output will go high and the current source will shut off. At this time the current source has injected an amount of charge $Q=I_0T$ into the network R_B-C_B . If this charge has not increased the voltage V_B such that $V_B > V_1$, the comparator again fires the one-shot and the current source injects another lump of charge, Q , into the R_B-C_B network. This process continues until $V_B > V_1$.

When this condition is achieved the current source remains off and the voltage V_B decays until V_B is again equal to V_1 . This completes one cycle. The VFC will now run in a steady state mode. The current source dumps lumps of charge into the capacitor C_B at rate fast enough to keep $V_B \geq V_1$. Since the discharge rate of capacitor C_B is proportional to V_B/R_B , the frequency at which the system runs will be proportional to the input voltage.

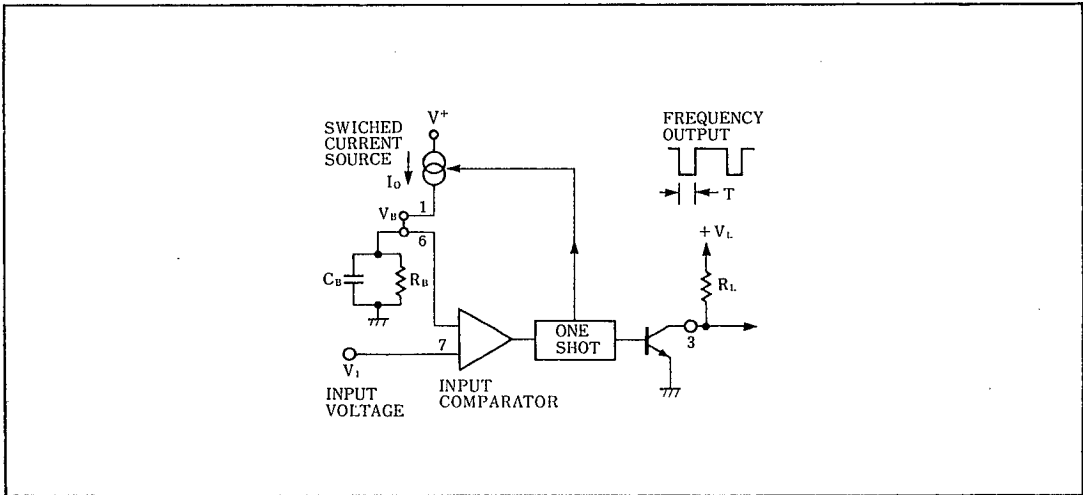

Figure 1. Simplified Block Diagram, Single Supply Mode

The 4151 VFC is easy to use and apply if you understand the operation of it through the block diagram, Figure 1. Many users, though, have expressed the desire to understand the workings of the internal circuitry. The circuit can be divided into five sections: the internal biasing network, input comparator, one-shot, voltage reference, and the output current source.

The internal biasing network is composed of Q39-Q43. The N-channel FET Q43 supplies the initial current for zener diode Q39. The NPN transistor Q38 senses the zener voltage to derive the current reference for the multiple collector current source Q41. This special PNP transistor provides active pull-up for all of the other sections of the 4151.

The input comparator section is composed of Q1-Q7. Lateral PNP transistors Q1-Q4 form the special ground-sensing input which is necessary for VFC operation at low input voltages. NPN transistors Q5 and Q6 convert the differential signal to drive the second gain stage Q7. If the voltage on input pin 7 is less than that on threshold pin 6, the comparator will be off and the collector of Q7 will be in the high state. As soon as the voltage on pin 7 exceeds the voltage on pin 6, the collector of Q7 will go low and trigger the one-shot.

The one-shot is made from a voltage comparator and an R-S latch. Transistors Q12-Q15 and Q18-Q20 form the comparator, while Q8-Q11 and Q16-Q17 make up the R-S latch. One latch output, open-collector reset transistor Q16, is connected to a comparator input and to the terminal, pin 5. Timing resistor R_O is tied externally from pin 5 to V^+ and timing capacitor C_O is tied from pin 5 to ground. The other comparator input is tied to a voltage divider R_3 - R_5 which sets the comparator threshold voltage at $0.667 V^+$. One-shot operation is initiated when the collector of Q7 goes low and sets the latch. This causes Q16 to turn off, releasing the voltage at pin 5 to charge exponentially towards V^+ through R_O . As soon as this voltage reaches $0.667 V^+$, comparator output Q20 will go high causing Q10 to reset the latch. When the latch is reset, Q16 will discharge C_O to ground. The one-shot has now completed its function of creating a pulse of period $T=1.1 R_O C_O$ at the latch output, Q21. This pulse is buffered through Q23 to drive the open-collector logic circuit transistor Q32. During the one-shot period the logic output will be in the low state. The one-shot output is also used to switch the reference voltage by Q22 and Q24. The low T.C. reference voltage is derived from the combination of a 5.5V zener diode with resistor and diode level shift networks. A stable 1.89 volts is developed at pin 2, the emitter of Q33.

Connecting the external current-setting resistor $R_S=14.0\Omega$ from pin 2 to ground gives $135\mu A$ from the collectors of Q33 and Q34. This current is reflected in the precision current mirror Q35-Q37 and produces the output current I_O at pin 1. When the R-S latch is reset, Q22 and Q24 will hold the reference voltage off, pin 2 will be at 0V, and the current will be off. During the one-shot period T, the latch will be set, the voltage of pin 2 will go to 1.89V, and the output current will be switched on.

■ TYPICAL APPLICATION

1. Single supply Voltage-to-Frequency Converter

Figure 2 shows the simplest type of VFC that can be made with the 4151. Input voltage range is from 0 to +10V, and output frequency is from 0 to 10kHz. Full scale frequency can be tuned by adjusting R_S , the output current-set resistor. This circuit has the advantage of being simple and low in cost, but it suffers from inaccuracy due to a number of error sources. Linearity error is typically 1%. A frequency offset will also be introduced by the input comparator offset voltage. Also, response time for this circuit is limited by the passive integration network $R_B C_B$. For the component values shown in Figure 2, response time for a step change input from 0 to +10V will be 135msec. For applications which require fast response time and high accuracy, use the circuits of Figure 3 and 4.

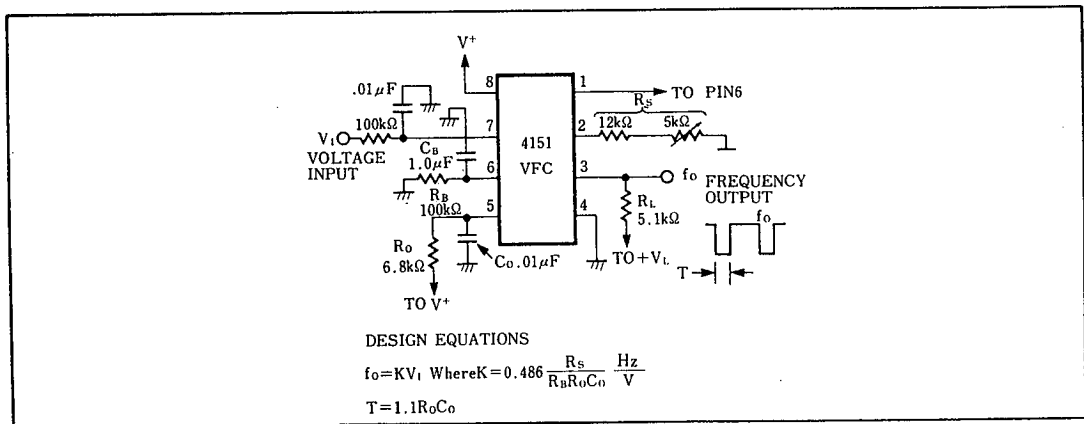

Figure 2. Single Supply Voltage-to-Frequency Converter

4. Comparison of Voltage-to-Frequency Application Circuits

Table 1 compares the VFC applications circuits for typical linearity, frequency offset, response time for a step input from 0 to 10 volts, sign of input voltage, and whether the circuit will operate from a single positive supply or split supplies.

Table 1

	Figure 2	Figure 3	Figure 4
Linearity	1%	0.2%	0.05%
Frequency Offset	+10Hz	0	0
Response Time	135msec	10msec	10msec
Input Voltage	+	+	-
Single supply	yes	yes	yes
Split Supply	-	-	yes

5. Frequency-to-Voltage Conversion

The 4151 can be used as a frequency-to-voltage converter. Figure 5 shows the single-supply FVC configuration. With no signal applied, the resistor bias networks tied to pins 6 and 7 hold the input comparator in the off state. A negative going pulse applied to pin 6 (or positive pulse to pin 7) will cause the comparator to fire the one-shot. For proper operation, pulse width must be less than the period of the one-shot, $T=1.1 R_0 C_0$. For a 5Vp-p square-wave input the differentiator network formed by the input coupling capacitor and the resistor bias network will provide pulses which correctly trigger the one-shot. An external voltage comparator such as the NJM311 or NJM2901 can be used to "square-up" sinusoidal input signals before they are applied to the 4151. Also, the component values for the input signal differentiator and bias network can be altered to accommodate square waves with different amplitudes and frequencies. The passive integrator network $R_B C_B$ filters the current pulses from the pin 1 output. For less output ripple, increase the value of C_B .

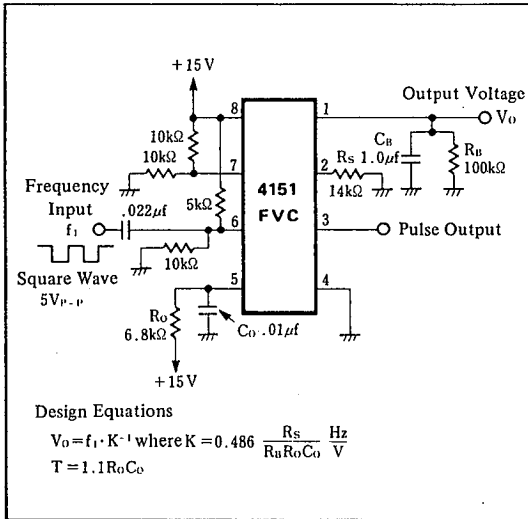

Figure 5. Single Supply Frequency-to-Voltage Converter

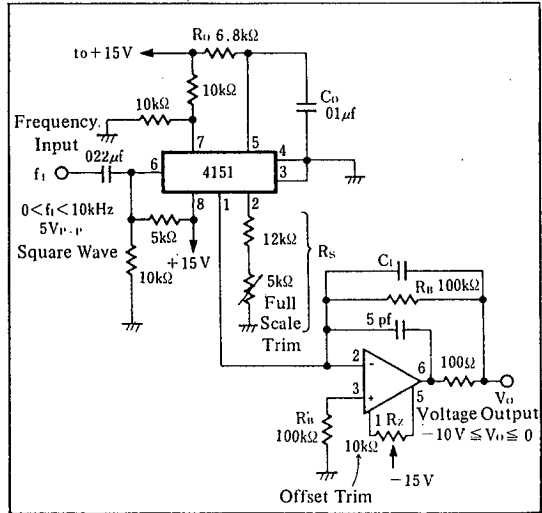

Figure 6. Precision Frequency-to-Voltage Converter

6. Precision Frequency-to-Voltage Converter

For increased accuracy and linearity, use an operational amplifier integrator as shown in Figure 6, the precision FVC configuration. Trim the offset to give -10mV out with 10Hz in and trim the full scale adjust for -10V out with 10kHz in. Input signal conditioning for this circuit is necessary just as for the single supply mode, and scale factor can be programmed by the choice of component values. A tradeoff exists between output ripple and response time, through the choice of integration capacitor C_1 . If $C_1=0.1\mu\text{F}$ the ripple will be about 100mV . Response time constant $\tau_R=R_B \cdot C_1$. For $R_B=100\text{k}\Omega$ and $C_1=0.1\mu\text{F}$, $\tau_R=10\text{ms}$

■ PRECAUTIONS

1. The voltage applied to comparator input pins 6 and 7 should not be allowed to go below ground by more than 0.3 volt.
2. Pins 3 and 5 are open-collector outputs. Shorts between these pins and V_+ can cause overheating and eventual destruction.
3. Reference voltage terminal pin 2 is connected to the emitter of an NPN transistor and is held at approximately 1.9 volts. This terminal should be protected from accidental shorts to ground or supply voltages. Permanent damage may occur if current in pin 2 exceeds 5mA .
4. Avoid stray coupling between 4151 pins 5 and 7, which could cause false triggering. For the circuit of Figure 2, bypass pin 7 to ground with at least $0.01\mu\text{F}$. If false triggering is experienced with the precision mode circuits, bypass pin 6 to ground with at least $0.01\mu\text{F}$. This is necessary for operation above 10kHz .

■ PROGRAMMING THE 4151

The 4151 can be programmed to operate with a full scale frequency anywhere from 1.0Hz to 100kHz . In the case of the VFC configuration, nearly any full scale input voltage from 1.0V and up can be tolerated if proper scaling is employed. Here is how to determine component values for any desired full scale frequency.

1. Set $R_S=14\text{k}\Omega$ or use a $12\text{k}\Omega$ resistor and $5\text{k}\Omega$ pot as shown in the figures. (The only exception to this is Figure 4.)
2. Set $T=1.1R_0C_0=0.75[1/f_0]$ where f_0 is the desired full scale frequency. For optimum performance make $6.8\text{k}\Omega < R_0 < 680\text{k}\Omega$ and $0.001\mu\text{F} < C_0 < 1.0\mu\text{F}$
3.
 - a) For the circuit of Figure 2 make $C_B=10^{-2}[1/f_0]$ Farads. Smaller values of C_B will give faster response time, but will also increase frequency offset and nonlinearity.
 - b) For the active integrator circuits make $C_1=5 \times 10^{-5}[1/f_0]$ Farads. The op-amp integrator must have a slew rate of at least $135 \times 10^{-6}[1/C_1]$ volts per second where the value of C_1 is again give in Frads.
4.
 - a) For the circuits of Figure 2 and 3 keep the values of R_B and R_B' as shown and use an input attenuator to give the desired full scale input voltage.
 - b) For the precision mode circuit of Figure 4, set $R_{11}=V_{10}/100\mu\text{A}$ where V_{10} is the full scale input voltage. Alternately the op-amp inverting input (summing node) can be used as a current input with full scale input current $I_{10}=-100\mu\text{A}$.
5. For the FVCs, pick the value of C_B or C_1 to give the optimum tradeoff between response time and output ripple for the particular application.

■ DESIGN EXAMPLE

- I. Design a precision VFC (from Figure 4) with $f_0=100\text{kHz}$ and $V_{10}=-10\text{V}$.
 1. Set $R_S=14.0\text{k}\Omega$.
 2. $T=0.75(1/10^5)=7.5\mu\text{sec}$ Let $R_0=6.8\text{k}\Omega$ and $C_0=0.001\mu\text{F}$
 3. $C_1=5 \times 10^{-5}(1/10^5)=500\text{pF}$ Op-amp slew rate must be at least $\text{SR}=135 \times 10^{-6}(1/500\text{pF})=0.27\text{V}/\mu\text{sec}$
 4. $R_B=10\text{V}/100\mu\text{A}=100\text{k}\Omega$
- II. Design a precision VFC with $f_0=1\text{Hz}$ and $V_{10}=-10\text{V}$,
 1. Let $R_S=14.0\text{k}\Omega$.
 2. $T=0.75(1/1)=0.75\text{sec}$ Let $R_0=680\text{k}\Omega$ and $C_0=1.0\mu\text{F}$
 3. $C_1=5 \times 10^{-5}(1/1) \text{ F}=50\mu\text{F}$
 4. $R_{11}=100\text{k}\Omega$

- III. Design a single supply FVC to operate with a supply voltage of 8V and full scale input frequency $f_0=83.3\text{Hz}$. The output voltage must reach at least 0.63 of its final value in 200msec. Determine the output ripple.
1. Set $R_s=14.0\text{k}\Omega$.
 2. $T=0.75(1/83.3)=9\text{msec}$ Let $R_0=82\text{k}\Omega$ and $C_0=0.1\mu\text{F}$
 3. Since this FVC must operate from 8.0V, we shall make the full scale output voltage at pin 6 equal to 5.0V.
 4. $R_B=5\text{V}/100\mu\text{A}=50\text{k}\Omega$
 5. Output response time constant is $\tau_R \leq 20\text{msec}$ Therefore $C_B \leq \tau_R/R_B=200 \times 10^{-3}/50 \times 10^3=4\mu\text{F}$ Worst case ripple voltage is: $V_R=9\text{mS} \times 135\mu\text{A}/4\mu\text{F}=304\text{mV}$
- IV. Design an opto-isolated V_{FC} with high linearity which accepts a full scale input voltage of +10V. See Figure 7 for the final design. This circuit uses the precision mode VFC configuration for maximum linearity. The NJM3403A quad op-amp provides the functions of inverter, integrator, regulator, and LED driver.

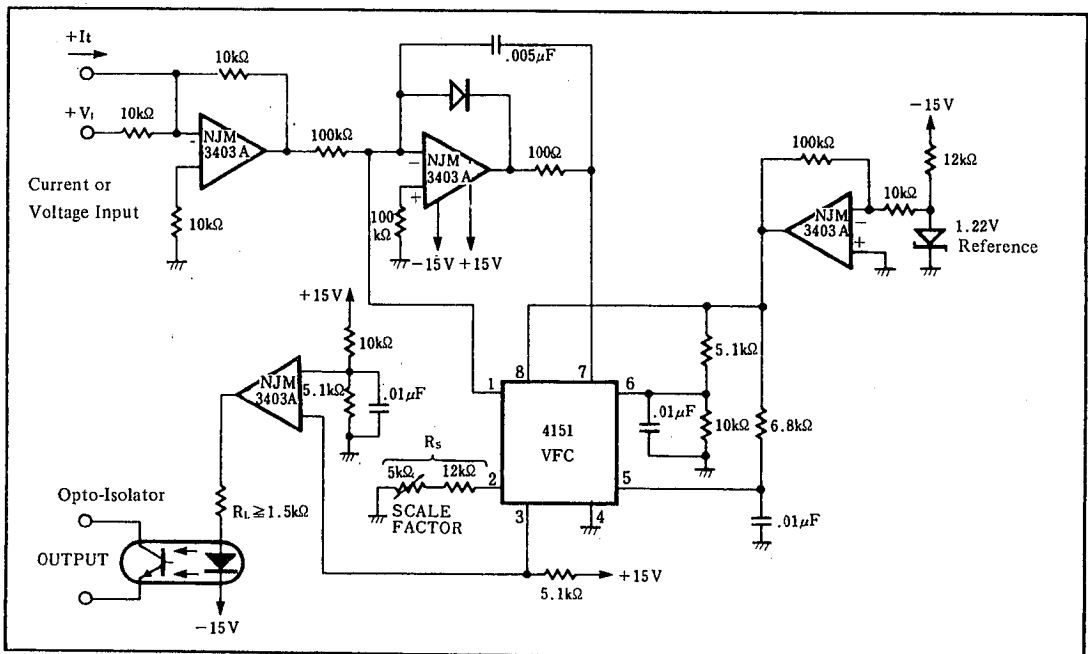
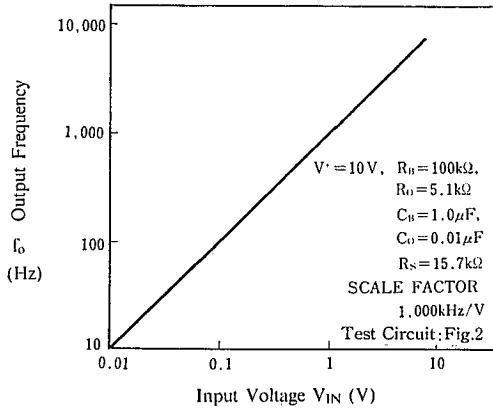

Figure 7. Opto-Isolated VFC,

■ TYPICAL CHARACTERISTICS

V_{IN}-fo Characteristics (VFC)



V_{IN}-fo Characteristics (VFC)

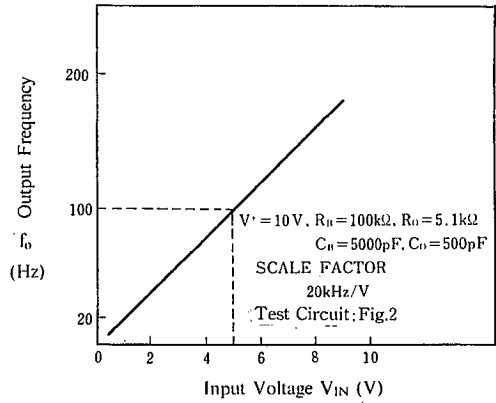

Scale Factor Characteristics

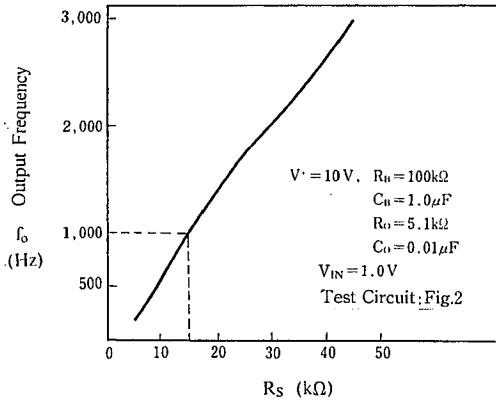

Input Frequency vs. Output Voltage (FVC)

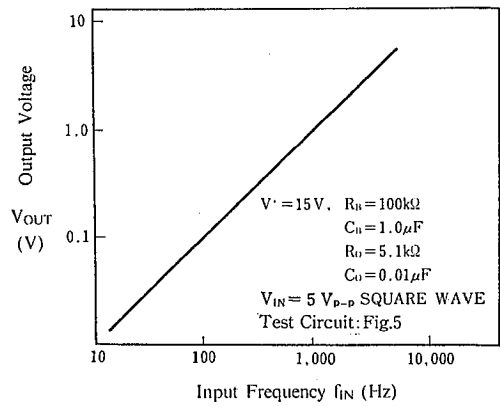

Ambient Temperature Characteristics

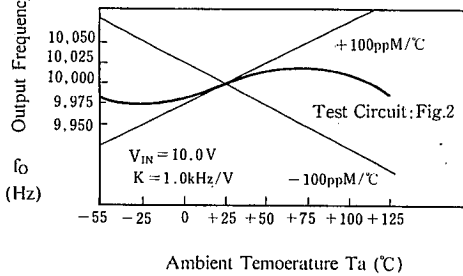

f_o vs. Operating Voltage

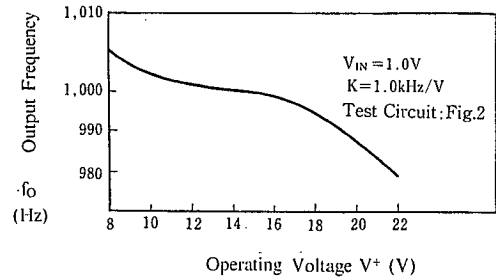

MEMO

[CAUTION]

The specifications on this databook are only given for information, without any guarantee as regards either mistakes or omissions. The application circuits in this databook are described only to show representative usages of the product and not intended for the guarantee or permission of any right including the industrial rights.

This datasheet has been download from:

www.datasheetcatalog.com

Datasheets for electronics components.