

# HETERO JUNCTION FIELD EFFECT TRANSISTOR NE32584C

### C to Ku BAND SUPER LOW NOISE AMPLIFIER N-CHANNEL HJ-FET

#### DESCRIPTION

The NE32584C is a Hetero Junction FET that utilizes the hetero junction to create high mobility electrons. Its excellent low noise and high associated gain make it suitable for DBS, TVRO and another commercial systems.

#### FEATURES

- Super Low Noise Figure & High Associated Gain  
NF = 0.45 dB TYP.,  $G_a = 12.5$  dB TYP. at  $f = 12$  GHz
- Gate Length :  $L_g \leq 0.2 \mu\text{m}$
- Gate Width .. :  $W_g = 200 \mu\text{m}$

#### ORDERING INFORMATION

PART NUMBER	SUPPLYING FORM	LEAD LENGTH	MARKING
NE32584C-SL	STICK	$L = 1.7$ mm MIN.	D
NE32584C-T1	Tape & reel 1000 pcs./reel	$L = 1.0 \pm 0.2$ mm	
NE32584C-T1A	Tape & reel 5000 pcs./reel	$L = 1.0 \pm 0.2$ mm	

#### ABSOLUTE MAXIMUM RATINGS ( $T_A = 25^\circ\text{C}$ )

Drain to Source Voltage	$V_{DS}$	4.0	V
Gate to Source Voltage	$V_{GS}$	-3.0	V
Drain Current	$I_D$	$I_{DSS}$	mA
Gate Current	$I_G$	100	$\mu\text{A}$
Total Power Dissipation	$P_{tot}$	165	mW
Channel Temperature	$T_{ch}$	150	$^\circ\text{C}$
Storage Temperature	$T_{stg}$	-65 to +150	$^\circ\text{C}$

#### RECOMMENDED OPERATING CONDITION ( $T_A = 25^\circ\text{C}$ )

CHARACTERISTIC	SYMBOL	MIN.	TYP.	MAX.	Unit
Drain to Source Voltage	$V_{DS}$		2	3	V
Drain Current	$I_D$		10	20	mA
Input Power	$P_{in}$			0	dBm

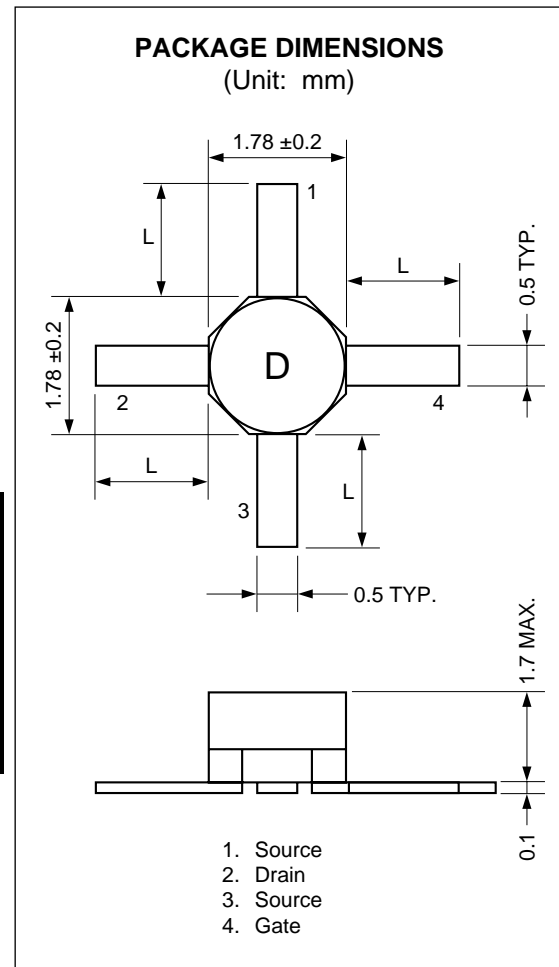

**ELECTRICAL CHARACTERISTICS (T<sub>A</sub> = 25 °C)**

CHARACTERISTIC	SYMBOL	MIN.	TYP.	MAX.	UNIT	TEST CONDITIONS
Gate to Source Leak Current	I <sub>GSO</sub>		0.5	10	μA	V <sub>GS</sub> = -3 V
Saturated Drain Current	I <sub>DSS</sub>	20	60	90	mA	V <sub>DS</sub> = 2 V, V <sub>GS</sub> = 0 V
Gate to Source Cutoff Voltage	V <sub>GS(off)</sub>	-0.2	-0.7	-2.0	V	V <sub>DS</sub> = 2 V, I <sub>D</sub> = 100 μA
Transconductance	g <sub>m</sub>	45	60		mS	V <sub>DS</sub> = 2 V, I <sub>D</sub> = 10 mA
Noise Figure	NF		0.45	0.55	dB	V <sub>DS</sub> = 2 V, I <sub>D</sub> = 10 mA, f = 12 GHz
Associated Gain	G <sub>a</sub>	11.0	12.5		dB	

**TYPICAL CHARACTERISTICS (T<sub>A</sub> = 25 °C)**

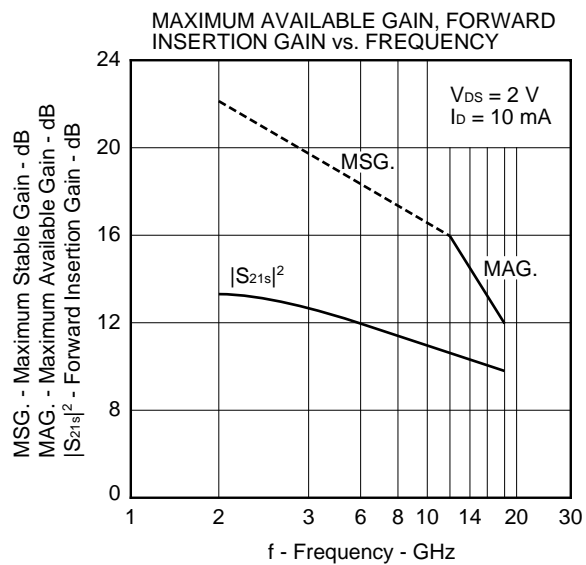
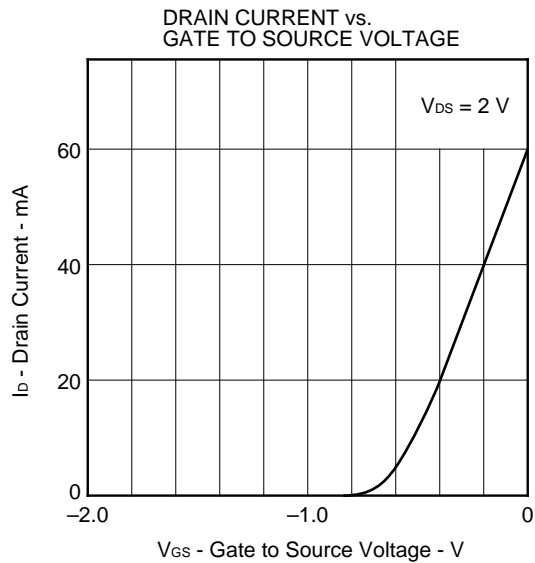
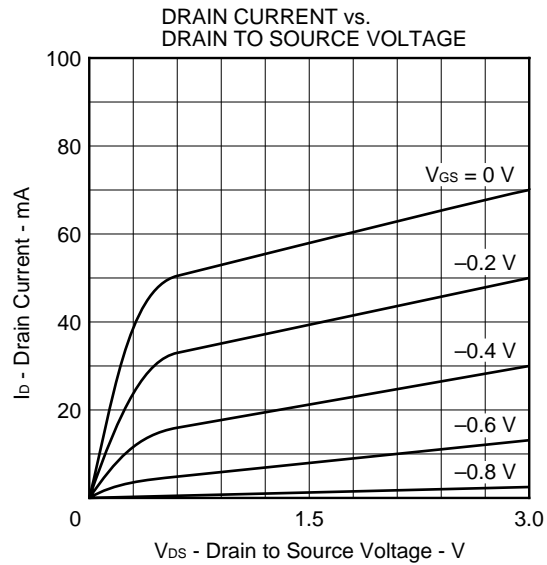
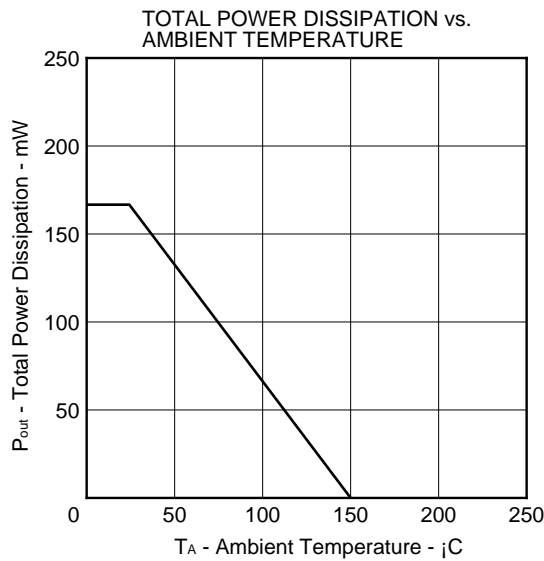

**Gain Calculations**

$$MSG. = \frac{|S_{21}|}{|S_{12}|}$$

$$K = \frac{1 + |\Delta|^2 - |S_{11}|^2 - |S_{22}|^2}{2|S_{12}||S_{21}|}$$

$$MAG. = \frac{|S_{21}|}{|S_{12}|} (K \pm \sqrt{K^2 - 1})$$

$$\Delta = S_{11} \cdot S_{22} - S_{21} \cdot S_{12}$$

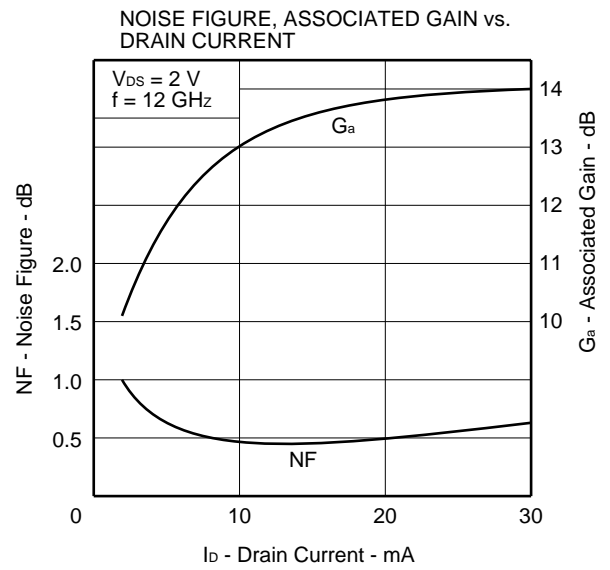
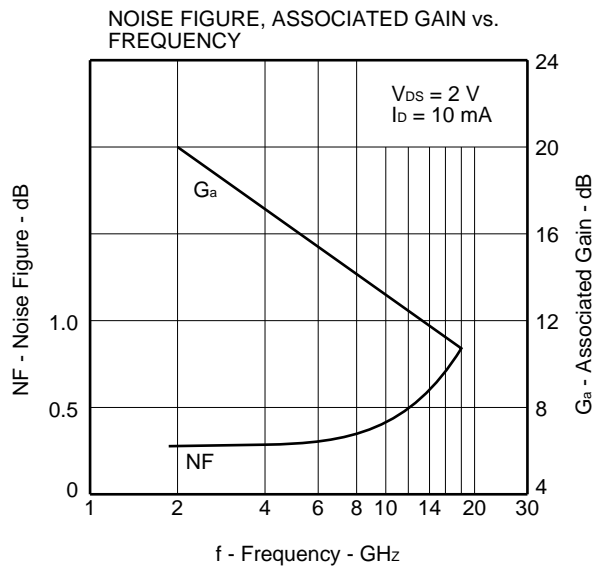

**S-PARAMETERS**

$V_{DS} = 2\text{ V}$ ,  $I_D = 10\text{ mA}$

START 2 GHz, STOP 18 GHz, STEP 500 MHz

Marker

1 : 4 GHz

2 : 8 GHz

3 : 12 GHz

4 : 16 GHz

5 : 18 GHz

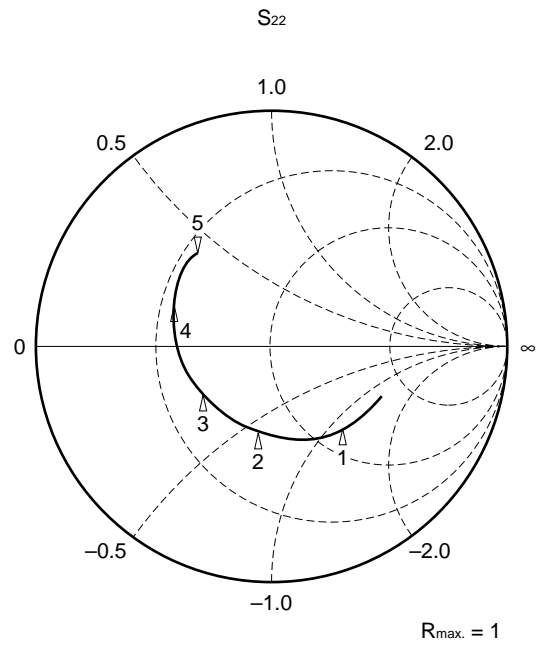
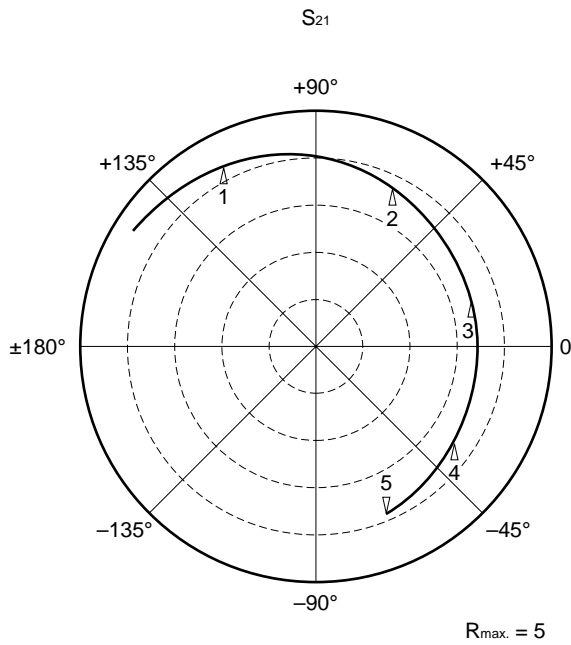
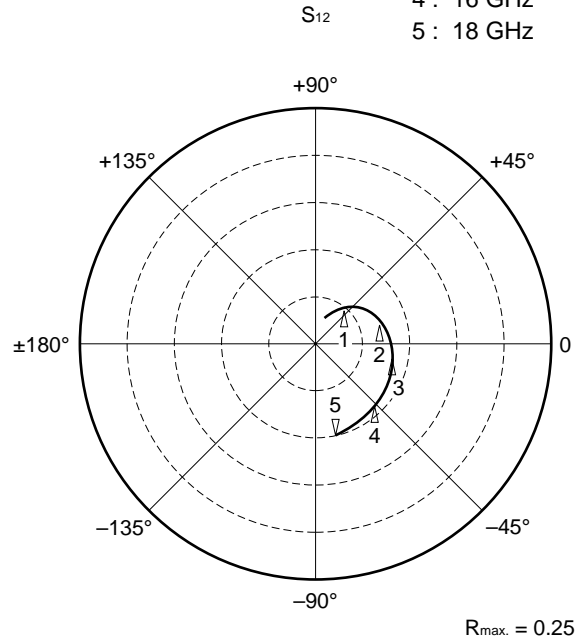
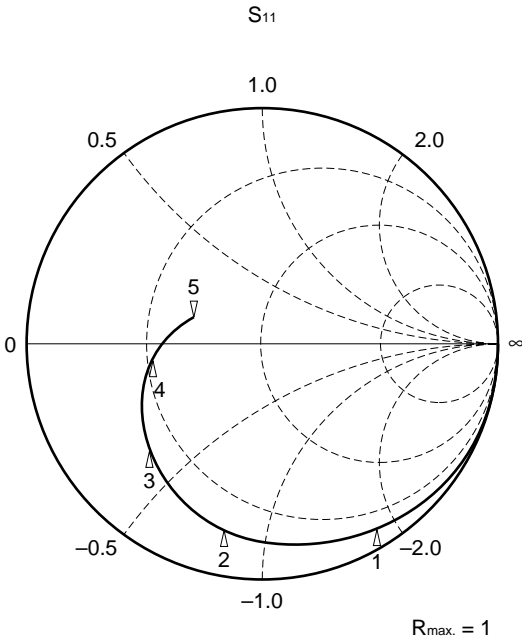

**S-PARAMETER**

MAG. AND ANG.

V<sub>DS</sub> = 2 V, I<sub>D</sub> = 10 mA

FREQUENCY GHz	S <sub>11</sub>		S <sub>21</sub>		S <sub>12</sub>		S <sub>22</sub>	
	MAG.	ANG. (deg.)	MAG.	ANG. (deg.)	MAG.	ANG. (deg.)	MAG.	ANG. (deg.)
2.0	.983	-29.7	4.648	148.4	.027	69.0	.532	-22.6
2.5	.973	-37.2	4.590	140.5	.033	65.3	.520	-28.3
3.0	.960	-43.9	4.543	133.2	.038	60.2	.508	-33.3
3.5	.943	-51.0	4.428	125.8	.044	55.7	.491	-39.3
4.0	.922	-58.0	4.351	118.2	.049	50.2	.472	-45.1
4.5	.912	-64.2	4.296	111.3	.054	45.6	.458	-51.3
5.0	.890	-70.4	4.174	104.5	.057	41.6	.442	-57.3
5.5	.870	-76.4	4.119	97.4	.062	37.7	.428	-63.6
6.0	.856	-81.8	4.005	91.0	.064	32.7	.416	-70.1
6.5	.840	-87.6	3.940	84.1	.068	29.7	.403	-76.0
7.0	.827	-92.5	3.877	78.1	.069	25.1	.395	-82.4
7.5	.816	-97.6	3.805	71.4	.072	21.8	.385	-88.5
8.0	.801	-102.3	3.720	65.3	.074	18.4	.376	-94.0
8.5	.784	-107.5	3.665	58.8	.075	14.9	.372	-99.9
9.0	.776	-112.1	3.604	52.6	.075	11.0	.364	-105.2
9.5	.752	-116.4	3.529	47.0	.077	9.0	.359	-112.7
10.0	.734	-119.8	3.491	41.5	.078	4.9	.357	-118.8
10.5	.713	-124.8	3.435	35.6	.079	2.5	.351	-126.0
11.0	.702	-128.1	3.438	29.7	.082	-1.5	.353	-133.7
11.5	.685	-131.7	3.434	24.0	.084	-5.9	.352	-140.6
12.0	.670	-136.1	3.429	17.6	.084	-8.4	.357	-147.5
12.5	.649	-139.7	3.443	11.6	.085	-12.8	.364	-155.0
13.0	.632	-143.8	3.423	5.1	.085	-17.3	.373	-161.3
13.5	.607	-148.2	3.414	-1.6	.086	-22.1	.384	-168.0
14.0	.588	-151.5	3.416	-7.5	.086	-25.3	.393	-174.7
14.5	.559	-156.1	3.443	-14.1	.088	-28.8	.406	178.1
15.0	.535	-161.6	3.462	-20.8	.089	-34.2	.422	171.4
15.5	.506	-165.4	3.519	-27.4	.092	-39.4	.437	164.2
16.0	.474	-171.6	3.564	-34.3	.092	-43.6	.451	156.3
16.5	.445	-177.1	3.644	-41.8	.095	-52.4	.466	150.0
17.0	.397	175.6	3.678	-49.8	.097	-58.3	.483	142.0
17.5	.356	167.7	3.754	-58.6	.097	-66.4	.484	134.8
18.0	.299	157.7	3.792	-67.6	.094	-74.5	.488	126.3

**AMP. PARAMETERS**

$V_{DS} = 2\text{ V}$ ,  $I_D = 10\text{ mA}$

FREQUENCY	GUmax.	GAmx.	$ S_{21} ^2$	$ S_{12} ^2$	K	Delay	Mason'sU	G1	G2
GHz	dB	dB	dB	dB		ns	dB	dB	dB
2.0	29.58		13.35	-31.40	.16	.044		14.79	1.44
2.5	27.27		13.24	-29.58	.19	.044		12.67	1.37
3.0	25.46		13.15	-28.44	.25	.040		11.02	1.30
3.5	23.65		12.93	-27.10	.30	.041		9.53	1.20
4.0	22.13		12.77	-26.26	.37	.042		8.26	1.09
4.5	21.43		12.66	-25.40	.39	.039		7.74	1.02
5.0	20.16		12.41	-24.82	.44	.038		6.81	.94
5.5	19.32		12.29	-24.18	.48	.039		6.14	.88
6.0	18.62		12.05	-23.83	.52	.036		5.74	.83
6.5	18.00		11.91	-23.39	.55	.038		5.32	.77
7.0	17.50		11.77	-23.16	.59	.034		5.00	.74
7.5	17.07		11.61	-22.83	.60	.037		4.76	.70
8.0	16.53		11.41	-22.62	.64	.034		4.46	.66
8.5	16.06		11.28	-22.46	.68	.036		4.13	.65
9.0	15.75		11.14	-22.44	.72	.035		4.00	.62
9.5	15.18		10.95	-22.27	.76	.031		3.62	.60
10.0	14.81		10.86	-22.21	.81	.030	34.849	3.36	.59
10.5	14.38		10.72	-22.02	.85	.033	34.181	3.09	.57
11.0	14.25		10.73	-21.68	.84	.033		2.95	.58
11.5	14.04		10.72	-21.53	.87	.032		2.75	.57
12.0	13.88		10.70	-21.55	.89	.035		2.59	.59
12.5	13.73		10.74	-21.41	.91	.034		2.38	.62
13.0	13.56		10.69	-21.36	.94	.036	31.704	2.22	.65
13.5	13.35		10.66	-21.34	.98	.037	26.609	1.99	.69
14.0	13.24		10.67	-21.32	1.00	.033	26.243	1.85	.73
14.5	13.15	15.61	10.74	-21.11	1.00	.037	27.185	1.63	.78
15.0	13.10	15.71	10.79	-21.05	1.01	.037	26.453	1.46	.85
15.5	13.14	15.59	10.93	-20.76	1.00	.036	28.874	1.29	.92
16.0	13.13	15.26	11.04	-20.77	1.01	.039	28.826	1.11	.99
16.5	13.25	15.65	11.23	-20.46	1.00	.042	30.042	.96	1.06
17.0	13.21	15.45	11.31	-20.25	1.00	.044	31.112	.75	1.16
17.5	13.24	14.73	11.49	-20.28	1.04	.049	26.111	.59	1.16
18.0	13.16	14.20	11.58	-20.55	1.09	.050	22.789	.41	1.18

**S-PARAMETER**

MAG. AND ANG.

V<sub>DS</sub> = 2 V, I<sub>D</sub> = 15 mA

FREQUENCY GHz	S <sub>11</sub>		S <sub>21</sub>		S <sub>12</sub>		S <sub>22</sub>	
	MAG.	ANG. (deg.)	MAG.	ANG. (deg.)	MAG.	ANG. (deg.)	MAG.	ANG. (deg.)
2.0	.981	-30.4	5.265	147.5	.062	71.1	.484	-21.9
3.0	.955	-44.8	5.113	132.2	.037	60.9	.460	-32.3
4.0	.911	-59.0	4.878	116.9	.047	52.4	.426	-43.9
5.0	.877	-71.4	4.647	103.2	.055	43.1	.396	-55.2
6.0	.839	-82.9	4.432	89.7	.061	35.6	.371	-67.4
7.0	.809	-93.5	4.268	76.8	.067	28.1	.351	-79.2
8.0	.781	-103.1	4.085	64.1	.070	22.6	.334	-90.4
9.0	.752	-112.7	3.942	51.5	.075	15.5	.325	-101.0
10.0	.710	-120.6	3.805	40.6	.079	9.1	.319	-114.1
11.0	.679	-128.7	3.736	28.7	.082	2.3	.318	-129.0
12.0	.646	-136.2	3.723	16.8	.084	-5.0	.324	-142.9
13.0	.608	-143.9	3.712	4.4	.085	-13.4	.343	-156.3
14.0	.562	-151.5	3.699	-8.2	.088	-20.8	.365	-169.8
15.0	.504	-160.6	3.738	-21.4	.091	-29.5	.395	176.1
16.0	.446	-170.5	3.845	-34.9	.093	-40.4	.429	160.6
17.0	.367	177.0	3.949	-50.4	.096	-54.5	.466	145.5
18.0	.273	160.9	4.050	-68.1	.099	-72.1	.473	130.2

**S-PARAMETER**

MAG. AND ANG.

V<sub>DS</sub> = 2 V, I<sub>D</sub> = 20 mA

FREQUENCY GHz	S <sub>11</sub>		S <sub>21</sub>		S <sub>12</sub>		S <sub>22</sub>	
	MAG.	ANG. (deg.)	MAG.	ANG. (deg.)	MAG.	ANG. (deg.)	MAG.	ANG. (deg.)
2.0	.979	-30.6	5.586	147.1	.025	69.2	.456	-21.4
3.0	.950	-45.1	5.411	131.7	.035	61.0	.431	-31.4
4.0	.907	-59.3	5.136	116.3	.045	52.8	.398	-42.3
5.0	.869	-71.7	4.882	102.6	.053	44.7	.368	-53.4
6.0	.832	-83.2	4.644	89.2	.059	37.0	.345	-65.3
7.0	.801	-93.6	4.459	76.4	.065	30.1	.327	-76.8
8.0	.772	-103.1	4.255	63.7	.070	24.7	.312	-87.4
9.0	.744	-112.8	4.108	51.3	.074	18.1	.303	-97.7
10.0	.702	-120.3	3.958	40.2	.077	11.4	.298	-110.8
11.0	.671	-128.3	3.891	28.5	.082	4.8	.297	-125.7
12.0	.634	-136.0	3.871	16.7	.086	-2.3	.304	-139.0
13.0	.597	-143.3	3.856	4.3	.087	-11.1	.325	-153.3
14.0	.551	-150.5	3.839	-8.2	.090	-18.9	.348	-166.8
15.0	.495	-159.3	3.877	-21.6	.094	-29.0	.384	179.4
16.0	.434	-169.2	3.976	-34.7	.094	-38.0	.421	163.1
17.0	.357	179.6	4.079	-50.2	.098	-53.0	.458	148.0
18.0	.261	164.4	4.195	-67.7	.098	-68.9	.469	132.4

**S-PARAMETER**

MAG. AND ANG.

V<sub>DS</sub> = 1 V, I<sub>D</sub> = 10 mA

FREQUENCY GHz	S <sub>11</sub>		S <sub>21</sub>		S <sub>12</sub>		S <sub>22</sub>	
	MAG.	ANG. (deg.)	MAG.	ANG. (deg.)	MAG.	ANG. (deg.)	MAG.	ANG. (deg.)
2.0	.987	-29.7	4.627	148.3	.028	70.0	.475	-22.4
3.0	.964	-43.9	5.522	133.2	.040	59.5	.451	-33.0
4.0	.927	-58.0	4.335	118.2	.051	50.7	.416	-44.9
5.0	.894	-70.5	4.158	104.5	.060	41.7	.386	-57.0
6.0	.860	-82.0	3.987	91.0	.069	33.0	.361	-69.9
7.0	.833	-92.5	3.854	78.2	.073	25.6	.340	-82.0
8.0	.806	-102.3	3.701	65.4	.078	17.4	.321	-94.2
9.0	.780	-112.3	3.587	52.8	.082	10.4	.310	-105.3
10.0	.739	-120.1	3.475	41.6	.086	4.9	.303	-119.5
11.0	.710	-128.4	3.417	29.8	.090	-3.4	.300	-135.2
12.0	.673	-136.6	3.415	17.7	.092	-11.5	.305	-149.4
13.0	.634	-144.6	3.410	5.3	.092	-19.3	.321	-163.9
14.0	.588	-152.5	3.399	-7.4	.095	-27.4	.342	-177.3
15.0	.532	-162.0	3.455	-20.7	.100	-39.0	.372	168.5
16.0	.473	-172.9	3.557	-34.3	.103	-50.0	.403	152.2
17.0	.392	173.7	3.667	-49.9	.107	-64.7	.435	137.4
18.0	.298	155.7	3.768	-67.9	.111	-80.8	.435	121.6

**S-PARAMETER**

MAG. AND ANG.

V<sub>DS</sub> = 3 V, I<sub>D</sub> = 10 mA

FREQUENCY GHz	S <sub>11</sub>		S <sub>21</sub>		S <sub>12</sub>		S <sub>22</sub>	
	MAG.	ANG. (deg.)	MAG.	ANG. (deg.)	MAG.	ANG. (deg.)	MAG.	ANG. (deg.)
2.0	.989	-29.2	4.146	149.0	.027	69.6	.548	-21.8
3.0	.967	-43.1	4.067	134.1	.038	59.5	.525	-32.5
4.0	.934	-57.2	3.923	119.1	.048	50.5	.492	-44.2
5.0	.901	-69.6	3.779	105.5	.055	41.0	.464	-55.9
6.0	.872	-81.0	3.645	92.0	.062	34.5	.439	-68.9
7.0	.847	-91.7	3.542	79.1	.066	25.9	.420	-81.0
8.0	.823	-101.6	3.412	66.2	.070	19.2	.400	-92.8
9.0	.798	-111.6	3.319	53.5	.071	12.8	.391	-104.0
10.0	.757	-119.4	3.226	42.4	.075	7.3	.382	-117.6
11.0	.730	-127.7	3.183	30.3	.077	0.3	.376	-132.8
12.0	.698	-135.9	3.188	18.2	.081	-6.0	.379	-146.0
13.0	.661	-144.1	3.192	5.7	.081	-13.0	.395	-159.7
14.0	.617	-152.5	3.185	-7.1	.082	-20.4	.415	-172.7
15.0	.561	-162.2	3.239	-20.4	.084	-29.2	.440	173.9
16.0	.503	-173.3	3.353	-33.9	.087	-38.8	.474	159.0
17.0	.428	172.5	3.459	-49.6	.091	-52.5	.506	145.2
18.0	.332	153.5	3.579	-67.5	.092	-68.5	.515	130.6

**NOISE PARAMETER**

<TYPICAL CONSTANT NOISE FIGURE CIRCLE>

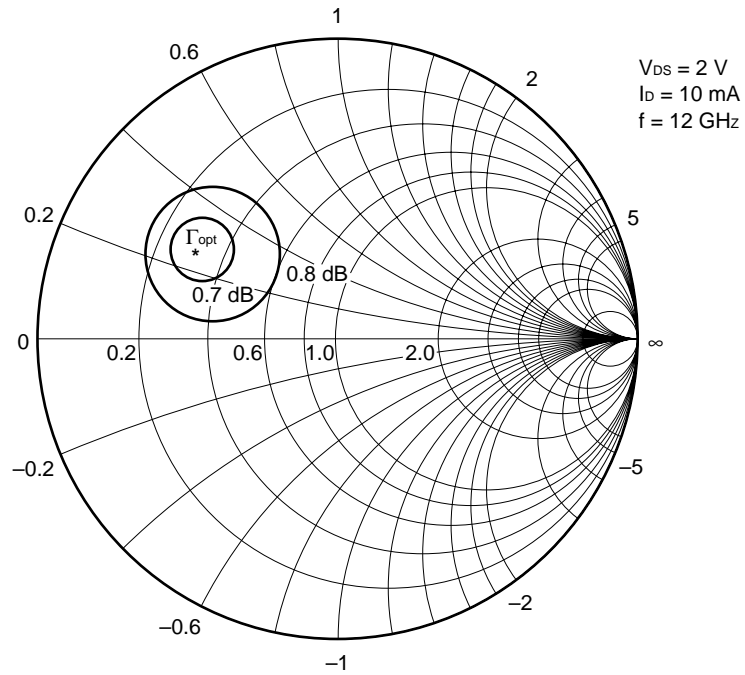

<NOISE PARAMETER>

$V_{DS} = 2\text{ V}$ ,  $I_D = 10\text{ mA}$

Freq. (GHz)	NF <sub>min.</sub> (dB)	G <sub>a</sub> (dB)	Γ <sub>opt.</sub>		R <sub>n</sub> /50
			MAG.	ANG. (deg.)	
2.0	0.29	20.0	0.86	22	0.27
4.0	0.30	18.3	0.76	45	0.25
6.0	0.33	16.5	0.69	70	0.18
8.0	0.36	15.0	0.63	96	0.11
10.0	0.40	13.6	0.59	122	0.08
12.0	0.45	12.5	0.54	147	0.04
14.0	0.54	12.0	0.48	171	0.04
16.0	0.68	11.8	0.40	-165	0.05
18.0	0.85	11.5	0.31	-144	0.06

**RECOMMENDED SOLDERING CONDITIONS**

The following conditions (see table below) must be met when soldering this product.

Please consult with our sales offices in case other soldering process is used, or in case soldering is done under different conditions.

**<TYPES OF SURFACE MOUNT DEVICE>**

For more details, refer to our document “SEMICONDUCTOR DEVICE MOUNTING TECHNOLOGY MANUAL” (C10535E).

[NE32584C]

Soldering process	Soldering conditions	Symbol
Infrared ray reflow	Peak package's surface temperature: 230 °C or below, Reflow time: 30 seconds or below (210 °C or higher), Number of reflow process: 1, Exposure limit*: None	IR30-00
Partial heating method	Terminal temperature: 230 °C or below, Flow time: 10 seconds or below, Exposure limit*: None	

\* Exposure limit before soldering after dry-pack package is opened.  
Storage conditions: 25 °C and relative humidity at 65 % or less.

**Note** Do not apply more than a single process at once, except for “Partial heating method”.

**PRECAUTION** Avoid high static voltage and electric fields, because this device is Hetero Junction field effect transistor with shottky barrier gate.

**Caution**

**The Great Care must be taken in dealing with the devices in this guide.  
The reason is that the material of the devices is GaAs (Gallium Arsenide), which is designated as harmful substance according to the law concerned.  
Keep the law concerned and so on, especially in case of removal.**

[MEMO]

No part of this document may be copied or reproduced in any form or by any means without the prior written consent of NEC Corporation. NEC Corporation assumes no responsibility for any errors which may appear in this document.

NEC Corporation does not assume any liability for infringement of patents, copyrights or other intellectual property rights of third parties by or arising from use of a device described herein or any other liability arising from use of such device. No license, either express, implied or otherwise, is granted under any patents, copyrights or other intellectual property rights of NEC Corporation or others.

While NEC Corporation has been making continuous effort to enhance the reliability of its semiconductor devices, the possibility of defects cannot be eliminated entirely. To minimize risks of damage or injury to persons or property arising from a defect in an NEC semiconductor device, customers must incorporate sufficient safety measures in its design, such as redundancy, fire-containment, and anti-failure features.

NEC devices are classified into the following three quality grades:

"Standard", "Special", and "Specific". The Specific quality grade applies only to devices developed based on a customer designated "quality assurance program" for a specific application. The recommended applications of a device depend on its quality grade, as indicated below. Customers must check the quality grade of each device before using it in a particular application.

Standard: Computers, office equipment, communications equipment, test and measurement equipment, audio and visual equipment, home electronic appliances, machine tools, personal electronic equipment and industrial robots

Special: Transportation equipment (automobiles, trains, ships, etc.), traffic control systems, anti-disaster systems, anti-crime systems, safety equipment and medical equipment (not specifically designed for life support)

Specific: Aircrafts, aerospace equipment, submersible repeaters, nuclear reactor control systems, life support systems or medical equipment for life support, etc.

The quality grade of NEC devices is "Standard" unless otherwise specified in NEC's Data Sheets or Data Books. If customers intend to use NEC devices for applications other than those specified for Standard quality grade, they should contact an NEC sales representative in advance.

Anti-radioactive design is not implemented in this product.

This datasheet has been download from:

[www.datasheetcatalog.com](http://www.datasheetcatalog.com)

Datasheets for electronics components.