

**MJ2955 (See 2N3055)**  
**MJ2955A**  
**(See 2N3055A)**

# Medium-Power Complementary Silicon Transistors

... for use as output devices in complementary general purpose amplifier applications.

- High DC Current Gain —  $h_{FE} = 4000$  (Typ) @  $I_C = 5.0$  Adc
- Monolithic Construction with Built-in Base-Emitter Shunt Resistors

**PNP**  
**MJ2500**

**MJ2501\***  
**NPN**

**MJ3000**

**MJ3001\***

\*Motorola Preferred Device

**10 AMPERE**  
**DARLINGTON**  
**POWER TRANSISTORS**  
**COMPLEMENTARY**  
**SILICON**  
**60-80 VOLTS**  
**150 WATTS**

## MAXIMUM RATINGS

Rating	Symbol	MJ2500 MJ3000	MJ2501 MJ3001	Unit
Collector-Emitter Voltage	$V_{CEO}$	60	80	Vdc
Collector-Base Voltage	$V_{CB}$	60	80	Vdc
Emitter-Base Voltage	$V_{EB}$	5.0		Vdc
Collector Current	$I_C$	10		Adc
Base Current	$I_B$	0.2		Adc
Total Device Dissipation @ $T_C = 25^\circ\text{C}$ Derate above $25^\circ\text{C}$	$P_D$	150 0.857		Watts W/ $^\circ\text{C}$
Operating and Storage Junction Temperature Range	$T_J, T_{stg}$	-55 to +200		$^\circ\text{C}$

## THERMAL CHARACTERISTICS

Characteristic	Symbol	Max	Unit
Thermal Resistance, Junction to Case	$\theta_{JC}$	1.17	$^\circ\text{C}/\text{W}$

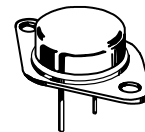

**CASE 1-07**  
**TO-204AA**  
**(TO-3)**

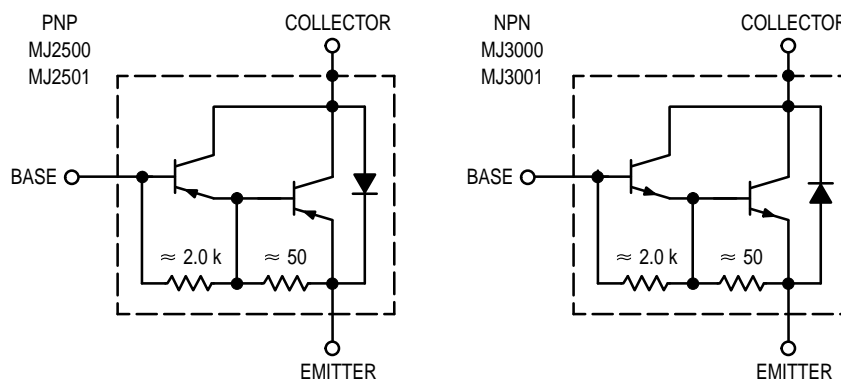

**Figure 1. Darlington Circuit Schematic**

Preferred devices are Motorola recommended choices for future use and best overall value.

REV 7

# MJ2500 MJ2501 MJ3000 MJ3001

## ELECTRICAL CHARACTERISTICS ( $T_C = 25^\circ\text{C}$ unless otherwise noted)

Characteristic	Symbol	Min	Max	Unit	
<b>OFF CHARACTERISTICS</b>					
Collector Emitter Breakdown Voltage <sup>(1)</sup> ( $I_C = 100\text{ mAdc}$ , $I_B = 0$ )	MJ2500, MJ3000 MJ2501, MJ3001	$V_{(BR)CEO}$	60 80	— —	Vdc
Collector–Emitter Leakage Current ( $V_{EB} = 60\text{ Vdc}$ , $R_{BE} = 1.0\text{ k ohm}$ ) ( $V_{EB} = 80\text{ Vdc}$ , $R_{BE} = 1.0\text{ k ohm}$ ) ( $V_{EB} = 60\text{ Vdc}$ , $R_{BE} = 1.0\text{ k ohm}$ , $T_C = 150^\circ\text{C}$ ) ( $V_{EB} = 80\text{ Vdc}$ , $R_{BE} = 1.0\text{ k ohm}$ , $T_C = 150^\circ\text{C}$ )	MJ2500, MJ3000 MJ2501, MJ3001 MJ2500, MJ3000 MJ2501, MJ3001	$I_{CER}$	— — — —	1.0 1.0 5.0 5.0	mAdc
Emitter Cutoff Current ( $V_{BE} = 5.0\text{ Vdc}$ , $I_C = 0$ )		$I_{EBO}$	—	2.0	mAdc
Collector Emitter Leakage Current ( $V_{CE} = 30\text{ Vdc}$ , $I_B = 0$ ) ( $V_{CE} = 40\text{ Vdc}$ , $I_B = 0$ )	MJ2500, MJ3000 MJ2501, MJ3001	$I_{CEO}$	— —	1.0 1.0	mAdc
<b>ON CHARACTERISTICS<sup>(1)</sup></b>					
DC Current Gain ( $I_C = 5.0\text{ Adc}$ , $V_{CE} = 3.0\text{ Vdc}$ )		$h_{FE}$	1000	—	—
Collector–Emitter Saturation Voltage ( $I_C = 5.0\text{ Adc}$ , $I_B = 20\text{ mAdc}$ ) ( $I_C = 10\text{ Adc}$ , $I_B = 50\text{ mAdc}$ )		$V_{CE(sat)}$	— —	2.0 4.0	Vdc
Base Emitter Voltage ( $I_C = 5.0\text{ Adc}$ , $V_{CE} = 3.0\text{ Vdc}$ )		$V_{BE(on)}$	—	3.0	Vdc

<sup>(1)</sup>Pulse Test: Pulse Width  $\leq 300\ \mu\text{s}$ , Duty Cycle  $\leq 2.0\%$ .

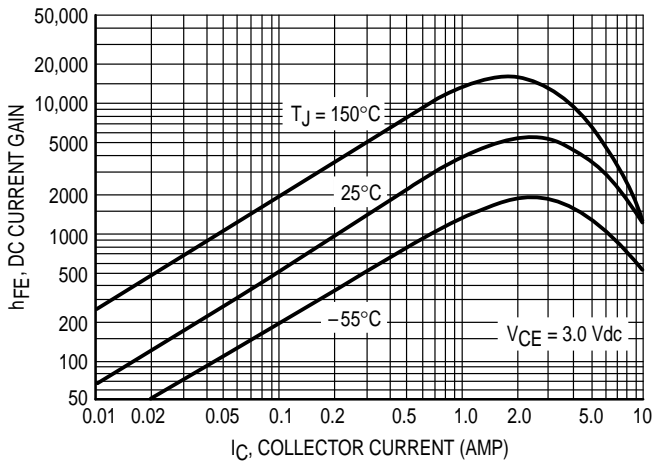

Figure 2. DC Current Gain

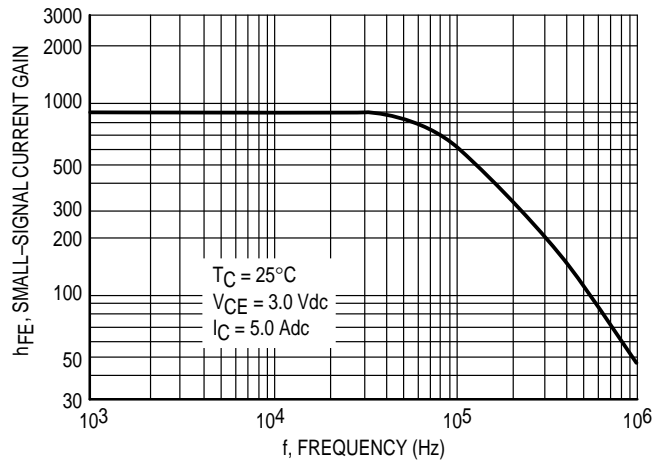

Figure 3. Small-Signal Current Gain

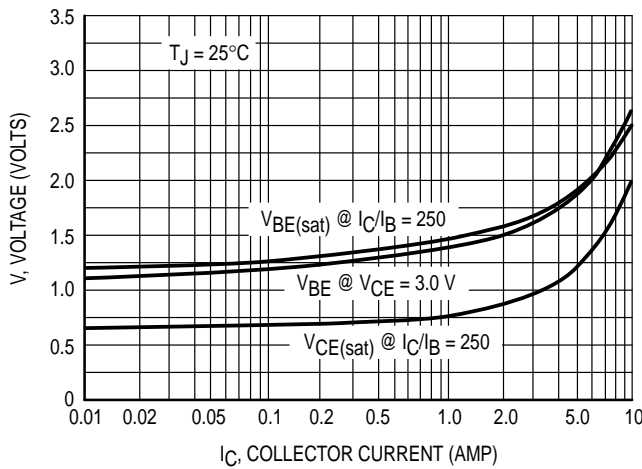

Figure 4. "On" Voltages

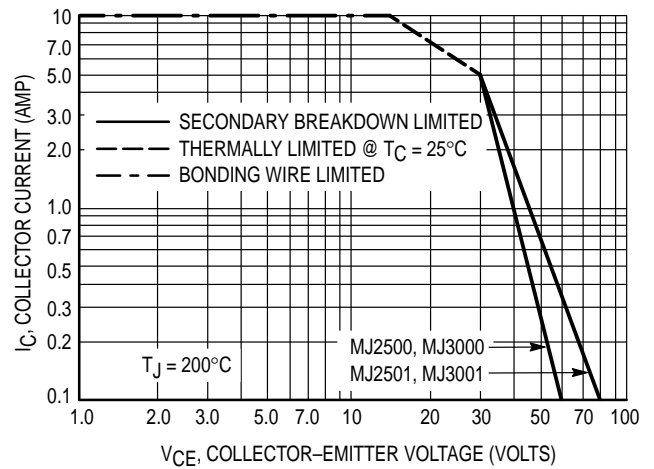

Figure 5. DC Safe Operating Area

There are two limitations on the power handling ability of a transistor: junction temperature and secondary breakdown. Safe operating area curves indicate  $I_C - V_{CE}$  limits of the transistor that must be observed for reliable operation; e.g., the transistor must not be subjected to greater dissipation

than the curves indicate.

At high case temperatures, thermal limitations will reduce the power that can be handled to values less than the limitations imposed by secondary breakdown.

PACKAGE DIMENSIONS

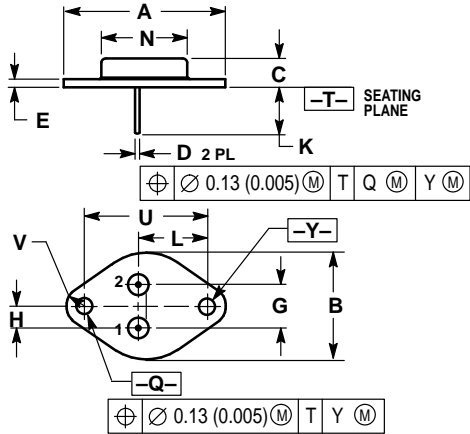

- NOTES:  
 1. DIMENSIONING AND TOLERANCING PER ANSI Y14.5M, 1982.  
 2. CONTROLLING DIMENSION: INCH.  
 3. ALL RULES AND NOTES ASSOCIATED WITH REFERENCED TO-204AA OUTLINE SHALL APPLY.

DIM	INCHES		MILLIMETERS	
	MIN	MAX	MIN	MAX
A	1.550 REF		39.37 REF	
B	—	1.050	—	26.67
C	0.250	0.335	6.35	8.51
D	0.038	0.043	0.97	1.09
E	0.055	0.070	1.40	1.77
G	0.430 BSC		10.92 BSC	
H	0.215 BSC		5.46 BSC	
K	0.440	0.480	11.18	12.19
L	0.665 BSC		16.89 BSC	
N	—	0.830	—	21.08
Q	0.151	0.165	3.84	4.19
U	1.187 BSC		30.15 BSC	
V	0.131	0.188	3.33	4.77

STYLE 1:  
 PIN 1. BASE  
 2. EMITTER  
 CASE: COLLECTOR

CASE 1-07  
 TO-204AA (TO-3)  
 ISSUE Z

Motorola reserves the right to make changes without further notice to any products herein. Motorola makes no warranty, representation or guarantee regarding the suitability of its products for any particular purpose, nor does Motorola assume any liability arising out of the application or use of any product or circuit, and specifically disclaims any and all liability, including without limitation consequential or incidental damages. "Typical" parameters can and do vary in different applications. All operating parameters, including "Typicals" must be validated for each customer application by customer's technical experts. Motorola does not convey any license under its patent rights nor the rights of others. Motorola products are not designed, intended, or authorized for use as components in systems intended for surgical implant into the body, or other applications intended to support or sustain life, or for any other application in which the failure of the Motorola product could create a situation where personal injury or death may occur. Should Buyer purchase or use Motorola products for any such unintended or unauthorized application, Buyer shall indemnify and hold Motorola and its officers, employees, subsidiaries, affiliates, and distributors harmless against all claims, costs, damages, and expenses, and reasonable attorney fees arising out of, directly or indirectly, any claim of personal injury or death associated with such unintended or unauthorized use, even if such claim alleges that Motorola was negligent regarding the design or manufacture of the part. Motorola and  are registered trademarks of Motorola, Inc. Motorola, Inc. is an Equal Opportunity/Affirmative Action Employer.

**How to reach us:**

**USA / EUROPE:** Motorola Literature Distribution;  
P.O. Box 20912; Phoenix, Arizona 85036. 1-800-441-2447

**JAPAN:** Nippon Motorola Ltd.; Tatsumi-SPD-JLDC, Toshikatsu Otsuki,  
6F Seibu-Butsuryu-Center, 3-14-2 Tatsumi Koto-Ku, Tokyo 135, Japan. 03-3521-8315

**MFAX:** RMFAX0@email.sps.mot.com – TOUCHTONE (602) 244-6609  
**INTERNET:** <http://Design-NET.com>

**HONG KONG:** Motorola Semiconductors H.K. Ltd.; 8B Tai Ping Industrial Park,  
51 Ting Kok Road, Tai Po, N.T., Hong Kong. 852-26629298



This datasheet has been download from:

[www.datasheetcatalog.com](http://www.datasheetcatalog.com)

Datasheets for electronics components.