



- 1 Introduction ..... 1
- 2 Block Diagram ..... 2
- 3 Signal and Connection Descriptions ..... 3
- 4 Environmental ..... 4
- 5 Mechanical ..... 4
- 6 Electrical ..... 4
- 7 Interfaces ..... 5
- 8 Antenna ..... 5
- 9 Development Tools ..... 5
- 10 Documentation ..... 5
- 11 Sales Package Contents ..... 6
- 12 Approval ..... 6

## 1 Introduction

The 71000 Development Kit for the Bluetooth Platform Solution from Motorola is a unique demonstration and development tool.

This product contains all of the hardware, software, and documentation needed to evaluate the functionality of the ICs making up Motorola’s Bluetooth platform solution chipset:

- MC71000 Bluetooth Baseband Controller IC
- MC13180 Bluetooth Low Power Wireless Data Transceiver IC
- MC13181 Wireless Power Management IC

Also, you can develop software and hardware solutions around the platform chipset. The 71000 Development Kit makes it possible to easily and quickly set up and start demonstrating a Class 2 Bluetooth solution, and it provides an efficient layout for the baseband and RF on an FR4 PCB substrate.

The primary applications of the 71000 Development Kit are:

- Evaluation of the platform chipset and its features
- Porting of a user Bluetooth stack to the Motorola Bluetooth hardware
- Prototyping of a Bluetooth-enabled host device
- Reference design for quick layout of a Bluetooth solution based on the MC71000 and MC13180 chipset

The 71000 Development Kit is Bluetooth 1.1 qualified and type approved in a great number of countries. See Section 12, “Approval,” for more information.

For detailed information on the ICs making up the platform chipset, refer to the data sheet for each of the ICs: MC71000, MC13180, and MC13181.

This document contains information on a product under development. Motorola reserves the right to change or discontinue this product without notice. © Motorola, Inc., 2003. All rights reserved.

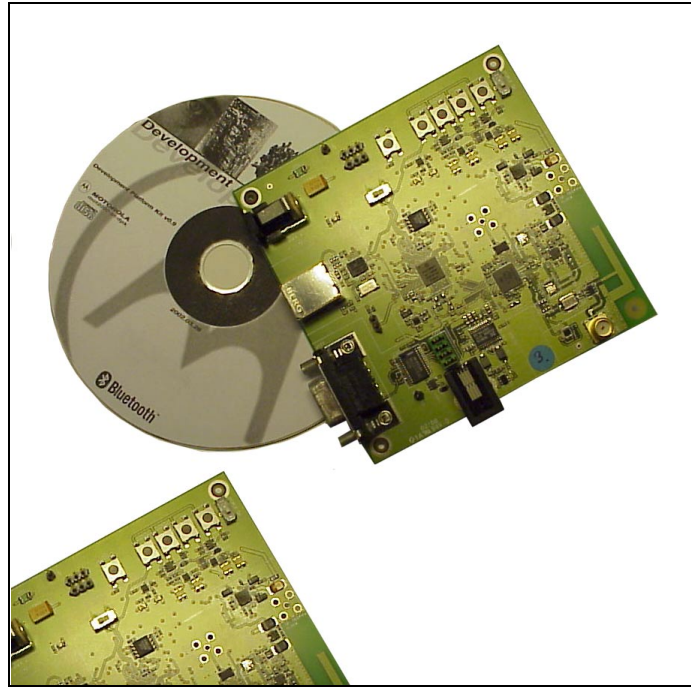

**Figure 1. Contents of 71000 Development Kit**

Two boards are included in the 71000 Development Kit. See Section 11, “Sales Package Contents,” for more information.

## 2 Block Diagram

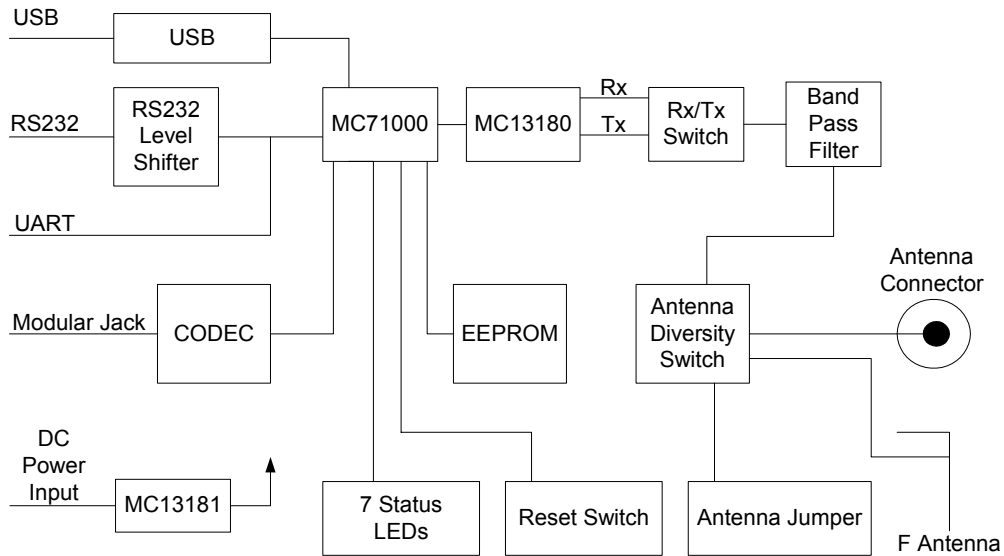

**Figure 2. Block Diagram**

### 3 Signal and Connection Descriptions

The 71000 Development Kit contains the following connections, switches, and indicators:

- Power supply input
- Modular jack 4/4 connector for mono-audio speaker and microphone (headset application)
- RS232 interface
- UART interface
- USB interface
- Antenna connector
- JTAG allowing interface to MC71000 production test
- Reset button
- Four control buttons for the headset application
- On/off switch
- Seven status LEDs
- Software download switch

The power supplied for the 71000 Development Kit is DC with the ratings stated in the specifications.

An analog audio signal to be transmitted over the Bluetooth connection can be fed into the 71000 Development Kit via the modular jack or as streaming audio through the host interface. It will be converted to digital data and transmitted through the Bluetooth link. A digital audio signal received from a connected Bluetooth device will be converted to an analog audio signal and available at the modular jack or as streaming audio through the host interface (UART, SSI, SPI). The MC71000 has a Bluetooth Audio Signal Processor (BTASP) for superior audio performance.

The RS232/UART interfaces can be used to transfer data and audio between a host and the Bluetooth device. The firmware of the 71000 Development Kit can be upgraded through the RS232/UART interface.

The USB interface is a standard HCI USB interface. This interface can be used to connect the 71000 Development Kit to a PC or other devices with PC-compatible USB connections.

The CODEC is attached to the MC71000 via the SPI (data) and SSI (streaming audio) interfaces.

The antenna connector is an SMA 50 ohm connection.

The reset button can be activated to re-initialize the entire system.

Four buttons are provided for embedded applications:

- Volume up
- Volume down
- Function 1 (connection etc.)
- Function 2 (an extra button)

Seven status LEDs are provided:

- Two application-specific LEDs
- Class 2
- 24 MHz/32 kHz
- RX/TX
- Power on

- Diversity (shows which antenna is being used)

## 4 Environmental

Table 1 contains system level environmental information about the development board:

**Table 1. Environmental Characteristics**

Characteristics	Minimum	Maximum
Storage temperature (degrees centigrade)	-40	+125
Operating temperature (degrees centigrade)	0	+85

## 5 Mechanical

This section contains system level mechanical information:

- Length: 100 mm
- Width: 100 mm
- Height (PCB with components): 20 mm
- Layout, FR4, 6 layer: 1 mm

## 6 Electrical

This section contains electrical information:

- Input power supply requirements: 3.5-6.5 VDC
- Audio input: 65m Vpp
- Audio output: 1.6 Vpp, modular jack 4/4 connector

Table 2 shows the current consumption measurements of the circuits of the MC71000 Bluetooth Baseband Controller and MC13180 Bluetooth Low Power Wireless Data Transceiver ICs. The values shown are typical values.

**Table 2. Current Consumption Measurements of MC71000 and MC13180 Circuits**

DH5 asymmetric RX	50.4 mA	TX rate 57.6 kbits RX rate 723.2 kbits
DH5 asymmetric TX	48.5 mA	TX rate 723.2 kbits RX rate 57.6 kbits
DH5 symmetric	45.8 mA	TX rate 433.9 kbits RX rate 433.9 kbits
HV1	45.8 mA	
HV3	27.8 mA	
Total system in low-power mode	0.130 mA	

## 7 Interfaces

The 71000 Development Kit features RS232, UART, and USB interfaces:

- RS232 interface: Programmable baud rate from 1200 to 921 Kbit.
- UART interface: 5-pin header with RxD, CTS, RTS, and GND, 3.3 V signaling, programmable baud rate from 1200 to 921 Kbit, HCI UART transport layer. Note that the UART and RS232 interfaces cannot operate simultaneously.
- USB interface: Full speed (12 Mbit/s) USB node device, HCI USB transport layer, 3.3 V operation, self-powered, National USBN9604 USB controller.

The following list shows the USB limitations:

- USB interface is for evaluation purposes and only included for ease of use.
- Supports OpenUSBDI-compatible USB controllers. USB v1.1.
- Does not support Open HCI.
- Production release of the MC71000 will not support USB.

## 8 Antenna

The 71000 Development Kit contains an F antenna and an SMA 50 ohm antenna connector.

## 9 Development Tools

The 71000 Development Kit includes the following software tools:

- HCI Terminal: This allows you to interact with your Bluetooth hardware. The interface is similar to that of an AT terminal application when communicating with a modem. You can send HCI commands from a computer to a Bluetooth device, and receive HCI responses from a Bluetooth device. The HCI Terminal allows you to get hands-on experience with the HCI or test your own hardware.
- Configuration Manager: This allows you to handle the 71000 Development Kit file system. You can download firmware patches and set up a number of baseband and radio parameters to exercise the board. All parameters will be restorable and default settings will be stored automatically.
- DemoBench: This allows you to send a file to another Bluetooth device, chat with another Bluetooth device, and/or view link and packet statistics in a real-time application.
- RadioTest: This allows you to test all aspects of your Bluetooth hardware. You can control your hardware and carry out any test required for development purposes and when preparing for production.

## 10 Documentation

The 71000 Development Kit contains the following documentation:

- User's guide providing the information needed to get started with the 71000 Development Kit
- User's guides for the various software tools accompanying the 71000 Development Kit
- Embedded system user's guide

- User's guide for the headset application
- Reference designs
- System overview of the Bluetooth Platform Solution from Motorola
- Data sheets for the various Bluetooth platform elements
- Application notes for the following:
  - Using the Bluetooth Audio Signal Processor (BTASP) for High-Quality Audio Performance
  - Motorola's Bluetooth Solution to Interference Rejection and Coexistence with 802.11
  - Enhancing ISM Band Performance Using Adaptive Frequency Hopping
- Data sheets for (third party) peripheral devices supported by the 71000 Development Kit
- Bluetooth Specification v1.1, Core Specification

## 11 Sales Package Contents

The 71000 Development Kit sales package contains the following items:

- 71000 development boards (2)
- Power supplies (2)
- UART/RS232 cables (2)
- USB cables (2)
- Headsets (2)
- Installation CD including software tools and documentation (1)

## 12 Approval

In the following countries, the 71000 Development Kit has obtained type approval:

- Europe (EU and EFTA countries)
- USA
- Canada
- Japan<sup>1</sup>

In the following countries, the 71000 Development Kit has not been type approved, however, prototypes may be shipped:

- China
- Taiwan
- Israel<sup>2</sup>
- Hong Kong
- Korea (South)
- Singapore

---

1. The equipment will be tested at accredited in-country test house. No actual application will be submitted because the 71000 development board has no enclosure, which is required to obtain Japanese type approval.  
2. Awaiting new regulations.

- Brazil
- Mexico<sup>1</sup>

---

1. Awaiting new regulations.

## HOW TO REACH US:

### USA/EUROPE/LOCATIONS NOT LISTED:

Motorola Literature Distribution;  
P.O. Box 5405, Denver, Colorado 80217  
1-303-675-2140 or 1-800-441-2447

### JAPAN:

Motorola Japan Ltd.; SPS, Technical Information Center,  
3-20-1, Minami-Azabu Minato-ku, Tokyo 106-8573 Japan  
81-3-3440-3569

### ASIA/PACIFIC:

Motorola Semiconductors H.K. Ltd.; Silicon Harbour  
Centre, 2 Dai King Street, Tai Po Industrial Estate,  
Tai Po, N.T., Hong Kong  
852-26668334

### TECHNICAL INFORMATION CENTER:

1-800-521-6274

### HOME PAGE:

<http://www.motorola.com/semiconductors>

Information in this document is provided solely to enable system and software implementers to use Motorola products. There are no express or implied copyright licenses granted hereunder to design or fabricate any integrated circuits or integrated circuits based on the information in this document.

Motorola reserves the right to make changes without further notice to any products herein. Motorola makes no warranty, representation or guarantee regarding the suitability of its products for any particular purpose, nor does Motorola assume any liability arising out of the application or use of any product or circuit, and specifically disclaims any and all liability, including without limitation consequential or incidental damages. "Typical" parameters which may be provided in Motorola data sheets and/or specifications can and do vary in different applications and actual performance may vary over time. All operating parameters, including "Typicals" must be validated for each customer application by customer's technical experts. Motorola does not convey any license under its patent rights nor the rights of others. Motorola products are not designed, intended, or authorized for use as components in systems intended for surgical implant into the body, or other applications intended to support or sustain life, or for any other application in which the failure of the Motorola product could create a situation where personal injury or death may occur. Should Buyer purchase or use Motorola products for any such unintended or unauthorized application, Buyer shall indemnify and hold Motorola and its officers, employees, subsidiaries, affiliates, and distributors harmless against all claims, costs, damages, and expenses, and reasonable attorney fees arising out of, directly or indirectly, any claim of personal injury or death associated with such unintended or unauthorized use, even if such claim alleges that Motorola was negligent regarding the design or manufacture of the part.



Motorola and the Stylized M Logo are registered in the U.S. Patent and Trademark Office. The Bluetooth trademarks are owned by their proprietor and used by Motorola, Inc., under license. All other product or service names are the property of their respective owners. Motorola, Inc. is an Equal Opportunity/Affirmative Action Employer.

© Motorola, Inc. 2003

94001480600/D

Preliminary

**For More Information On This Product,  
Go to: [www.freescale.com](http://www.freescale.com)**

This datasheet has been download from:

[www.datasheetcatalog.com](http://www.datasheetcatalog.com)

Datasheets for electronics components.