

## SELF-OSCILLATING HALF-BRIDGE DRIVER

### Features

- Floating channel designed for bootstrap operation  
Fully operational to +600V  
Tolerant to negative transient voltage  
dV/dt immune
- Undervoltage lockout
- Programmable oscillator frequency

$$f = \frac{1}{1.4 \times (R_T + 150\Omega) \times C_T}$$

- Matched propagation delay for both channels
- Micropower supply startup current of 125  $\mu$ A typ.
- Low side output in phase with  $R_T$

### Description

The IR2155 is a high voltage, high speed, self-oscillating power MOSFET and IGBT driver with both high and low side referenced output channels. Proprietary HVIC and latch immune CMOS technologies enable ruggedized monolithic construction. The front end features a programmable oscillator which is similar to the 555 timer. The output drivers feature a high pulse current buffer stage and an internal deadtime designed for minimum driver cross-conduction. Propagation delays for the two channels are matched to simplify use in 50% duty cycle applications. The floating channel can be used to drive an N-channel power

### Product Summary

$V_{OFFSET}$	600V max.
Duty Cycle	50%
$I_{O+/-}$	210 mA / 420 mA
$V_{OUT}$	10 - 20V
Deadtime (typ.)	1.2 $\mu$ s

### Package

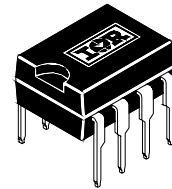

8 Lead PDIP

MOSFET or IGBT in the high side configuration that operates off a high voltage rail up to 600 volts.

### Typical Connection

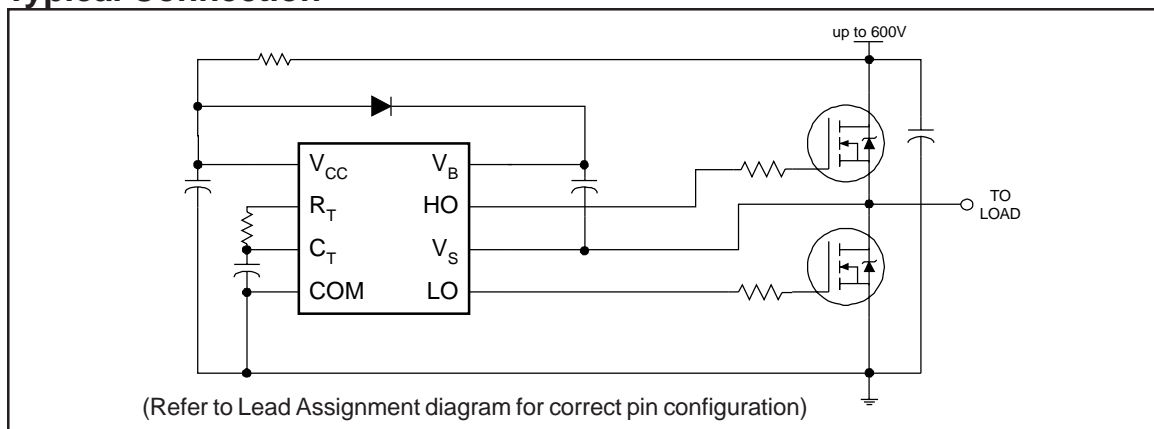

## Absolute Maximum Ratings

Absolute Maximum Ratings indicate sustained limits beyond which damage to the device may occur. All voltage parameters are absolute voltages referenced to COM. The Thermal Resistance and Power Dissipation ratings are measured under board mounted and still air conditions.

Symbol	Parameter Definition	Value		Units
		Min.	Max.	
V <sub>B</sub>	High Side Floating Supply Voltage	-0.3	625	V
V <sub>S</sub>	High Side Floating Supply Offset Voltage	V <sub>B</sub> - 25	V <sub>B</sub> + 0.3	
V <sub>HO</sub>	High Side Floating Output Voltage	V <sub>S</sub> - 0.3	V <sub>B</sub> + 0.3	
V <sub>LO</sub>	Low Side Output Voltage	-0.3	V <sub>CC</sub> + 0.3	
V <sub>RT</sub>	R <sub>T</sub> Voltage	-0.3	V <sub>CC</sub> + 0.3	
V <sub>CT</sub>	C <sub>T</sub> Voltage	-0.3	V <sub>CC</sub> + 0.3	
I <sub>CC</sub>	Supply Current (Note 1)	—	25	mA
I <sub>RT</sub>	R <sub>T</sub> Output Current	-5	5	
dV <sub>S</sub> /dt	Allowable Offset Supply Voltage Transient	—	50	V/ns
P <sub>D</sub>	Package Power Dissipation @ T <sub>A</sub> ≤ +25°C (8 Lead DIP)	—	1.0	W
	(8 Lead SOIC)	—	0.625	
R <sub>θJA</sub>	Thermal Resistance, Junction to Ambient (8 Lead DIP)	—	125	°C/W
	(8 Lead SOIC)	—	200	
T <sub>J</sub>	Junction Temperature	—	150	°C
T <sub>S</sub>	Storage Temperature	-55	150	
T <sub>L</sub>	Lead Temperature (Soldering, 10 seconds)	—	300	

## Recommended Operating Conditions

The Input/Output logic timing diagram is shown in Figure 1. For proper operation the device should be used within the recommended conditions. The V<sub>S</sub> offset rating is tested with all supplies biased at 15V differential.

Symbol	Parameter Definition	Value		Units
		Min.	Max.	
V <sub>B</sub>	High Side Floating Supply Absolute Voltage	V <sub>S</sub> + 10	V <sub>S</sub> + 20	V
V <sub>S</sub>	High Side Floating Supply Offset Voltage	—	600	
V <sub>HO</sub>	High Side Floating Output Voltage	V <sub>S</sub>	V <sub>B</sub>	
V <sub>LO</sub>	Low Side Output Voltage	0	V <sub>CC</sub>	
I <sub>CC</sub>	Supply Current (Note 1)	—	5	mA
T <sub>A</sub>	Ambient Temperature	-40	125	°C

Note 1: Because of the IR2155's application specificity toward off-line supply systems, this IC contains a zener clamp structure between the chip V<sub>CC</sub> and COM which has a nominal breakdown voltage of 15.6V. Therefore, the IC supply voltage is normally derived by forcing current into the supply lead (typically by means of a high value resistor connected between the chip V<sub>CC</sub> and the rectified line voltage and a local decoupling capacitor from V<sub>CC</sub> to COM) and allowing the internal zener clamp circuit to determine the nominal supply voltage. Therefore, this circuit should not be driven by a DC, low impedance power source of greater than V<sub>CLAMP</sub>.

**Dynamic Electrical Characteristics**

$V_{BIAS} (V_{CC}, V_{BS}) = 12V$ ,  $C_L = 1000 \text{ pF}$  and  $T_A = 25^\circ\text{C}$  unless otherwise specified.

Symbol	Parameter Definition	Value			Units	Test Conditions
		Min.	Typ.	Max.		
$t_r$	Turn-On Rise Time	—	80	120	ns	
$t_f$	Turn-Off Fall Time	—	40	70		
DT	Deadtime	0.50	1.20	2.25	$\mu\text{s}$	
D	$R_T$ Duty Cycle	48	50	52	%	

**Static Electrical Characteristics**

$V_{BIAS} (V_{CC}, V_{BS}) = 12V$ ,  $C_L = 1000 \text{ pF}$ ,  $C_T = 1 \text{ nF}$  and  $T_A = 25^\circ\text{C}$  unless otherwise specified. The  $V_{IN}$ ,  $V_{TH}$  and  $I_{IN}$  parameters are referenced to COM. The  $V_O$  and  $I_O$  parameters are referenced to COM and are applicable to the respective output leads: HO or LO.

Symbol	Parameter Definition	Value			Units	Test Conditions	
		Min.	Typ.	Max.			
$f_{OSC}$	Oscillator Frequency	19.4	20.0	20.6	kHz	$R_T = 35.7 \text{ k}\Omega$	
		94	100	106		$R_T = 7.04 \text{ k}\Omega$	
$V_{CLAMP}$	$V_{CC}$ Zener Shunt Clamp Voltage	14.4	15.6	16.8	V	$I_{CC} = 5 \text{ mA}$	
$V_{CT+}$	$2/3 V_{CC}$ Threshold	7.8	8.0	8.2			
$V_{CT-}$	$1/3 V_{CC}$ Threshold	3.8	4.0	4.2			
$V_{CTUV}$	$C_T$ Undervoltage Lockout	—	20	50	mV	$2.5V < V_{CC} < V_{CCUV}$	
$V_{RT+}$	$R_T$ High Level Output Voltage, $V_{CC} - R_T$	—	0	100		$I_{RT} = -100 \mu\text{A}$	
		—	200	300		$I_{RT} = -1 \text{ mA}$	
$V_{RT-}$	$R_T$ Low Level Output Voltage	—	20	50		$I_{RT} = 100 \mu\text{A}$	
		—	200	300		$I_{RT} = 1 \text{ mA}$	
$V_{RTUV}$	$R_T$ Undervoltage Lockout, $V_{CC} - R_T$	—	0	100		$2.5V < V_{CC} < V_{CCUV}$	
$V_{OH}$	High Level Output Voltage, $V_{BIAS} - V_O$	—	—	100	$I_O = 0 \text{ A}$		
$V_{OL}$	Low Level Output Voltage, $V_O$	—	—	100	$I_O = 0 \text{ A}$		
$I_{LK}$	Offset Supply Leakage Current	—	—	50	$\mu\text{A}$	$V_B = V_S = 600V$	
$I_{QBS}$	Quiescent $V_{BS}$ Supply Current	—	70	150			
$I_{QBSUV}$	Micropower $V_{BS}$ Supply Startup Current	—	55	125			
$I_{QCC}$	Quiescent $V_{CC}$ Supply Current	—	500	1000			
$I_{QCCUV}$	Micropower $V_{CC}$ Supply Startup Current	—	70	150			
$I_{CT}$	$C_T$ Input Current	—	0.001	1.0			
$V_{BSUV+}$	$V_{BS}$ Supply Undervoltage Positive Going Threshold	7.7	8.4	9.2		V	
$V_{BSUV-}$	$V_{BS}$ Supply Undervoltage Negative Going Threshold	7.3	8.1	8.9			
$V_{BSUVH}$	$V_{BS}$ Supply Undervoltage Lockout Hysteresis	100	400	—	mV		
$V_{CCUV+}$	$V_{CC}$ Supply Undervoltage Positive Going Threshold	7.7	8.4	9.2	V		
$V_{CCUV-}$	$V_{CC}$ Supply Undervoltage Negative Going Threshold	7.4	8.1	8.9			
$V_{CCUVH}$	$V_{CC}$ Supply Undervoltage Lockout Hysteresis	200	400	—	mV		
$I_{O+}$	Output High Short Circuit Pulsed Current	210	250	—	mA	$V_O = 0V$	
$I_{O-}$	Output Low Short Circuit Pulsed Current	420	500	—		$V_O = 15V$	

# IR2155

## Functional Block Diagram

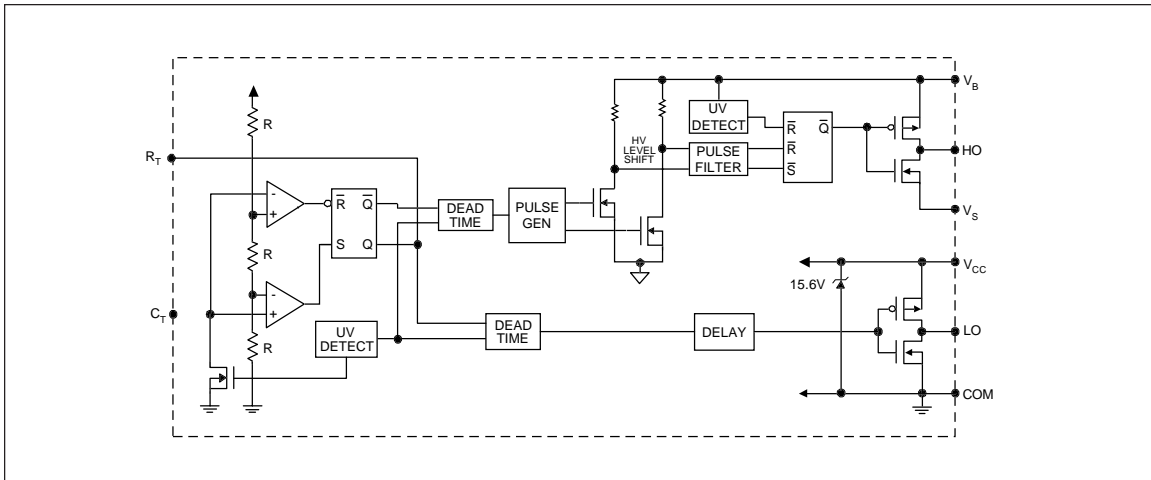

### Lead Definitions

Symbol	Description
R <sub>T</sub>	Oscillator timing resistor input, in phase with LO for normal IC operation
C <sub>T</sub>	Oscillator timing capacitor input, the oscillator frequency according to the following equation: $f = \frac{1}{1.4 \times (R_T + 150\Omega) \times C_T}$ where 150Ω is the effective impedance of the R <sub>T</sub> output stage
V <sub>B</sub>	High side floating supply
HO	High side gate drive output
V <sub>S</sub>	High side floating supply return
V <sub>CC</sub>	Low side and logic fixed supply
LO	Low side gate drive output
COM	Low side return

### Lead Assignments

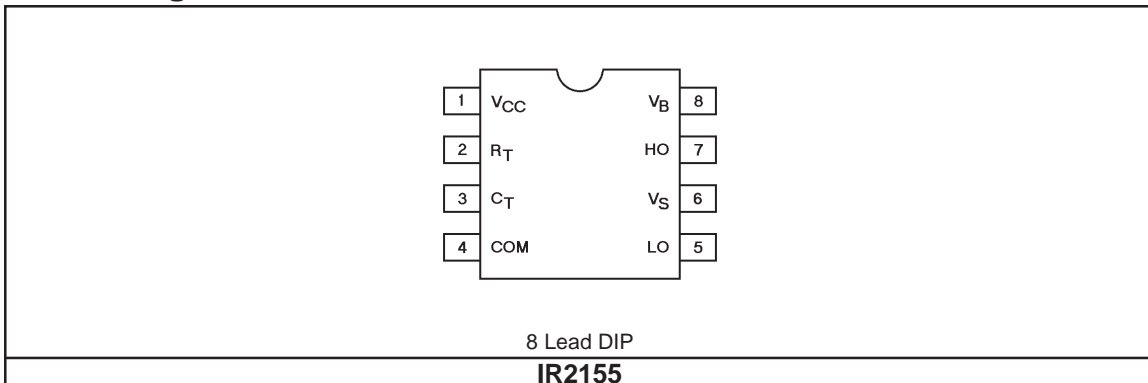

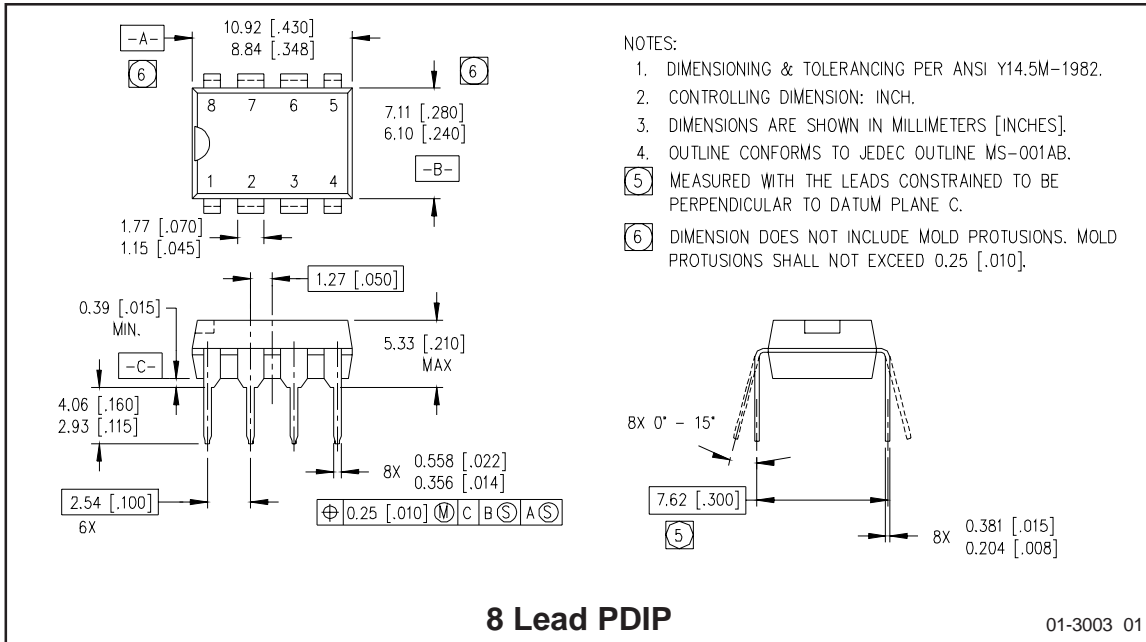

NOTES:

1. DIMENSIONING & TOLERANCING PER ANSI Y14.5M-1982.
2. CONTROLLING DIMENSION: INCH.
3. DIMENSIONS ARE SHOWN IN MILLIMETERS [INCHES].
4. OUTLINE CONFORMS TO JEDEC OUTLINE MS-001AB.
5. MEASURED WITH THE LEADS CONSTRAINED TO BE PERPENDICULAR TO DATUM PLANE C.
6. DIMENSION DOES NOT INCLUDE MOLD PROTUSIONS. MOLD PROTUSIONS SHALL NOT EXCEED 0.25 [.010].

**8 Lead PDIP**

01-3003 01

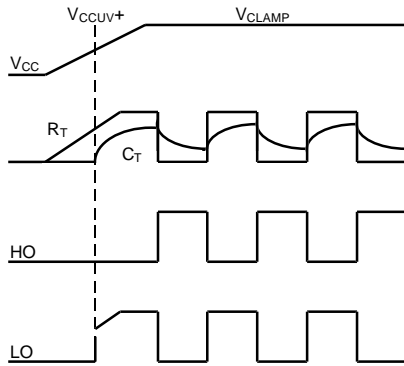

Figure 1. Input/Output Timing Diagram

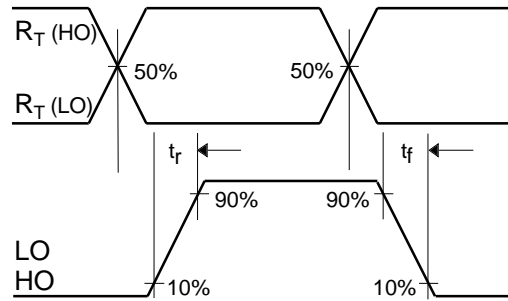

Figure 2. Switching Time Waveform Definitions

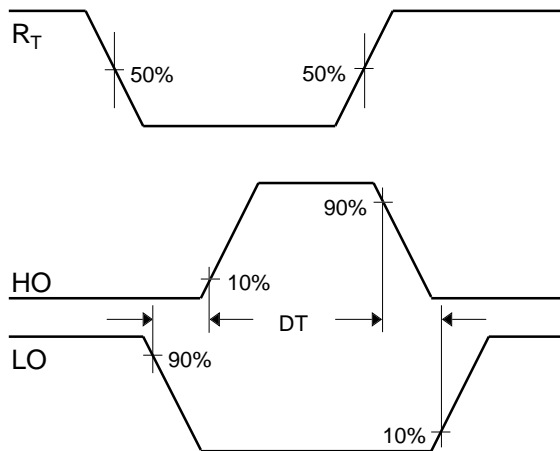

Figure 3. Deadtime Waveform Definitions

This datasheet has been download from:

[www.datasheetcatalog.com](http://www.datasheetcatalog.com)

Datasheets for electronics components.