

Features

- Compatible with MCS-51™ Products
- 4K Bytes of Reprogrammable Flash Memory
 - Endurance: 1,000 Write/Erase Cycles
- 2.7V to 6V Operating Range
- Fully Static Operation: 0 Hz to 12 MHz
- Three-Level Program Memory Lock
- 128 x 8-Bit Internal RAM
- 32 Programmable I/O Lines
- Two 16-Bit Timer/Counters
- Six Interrupt Sources
- Programmable Serial Channel
- Low Power Idle and Power Down Modes

Description

The AT89LV51 is a low-voltage, high-performance CMOS 8-bit microcomputer with 4K bytes of Flash Programmable and Erasable Read Only Memory. The device is manufactured using Atmel's high density nonvolatile memory technology and is compatible with the industry standard MCS-51™ instruction set and pinout. The on-chip Flash allows the program memory to be reprogrammed in-system or by a conventional nonvolatile memory programmer. By combining a versatile 8-bit CPU with Flash on a monolithic chip, the Atmel AT89LV51 is a powerful microcomputer which provides a highly flexible and cost effective solution to many embedded control applications. The AT89LV51 operates at 2.7 volts up to 6.0 volts.

(continued)

Pin Configurations

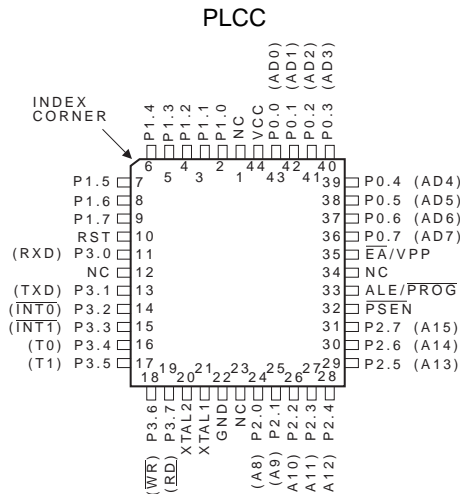
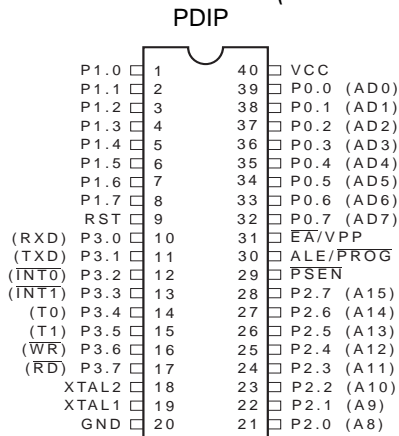
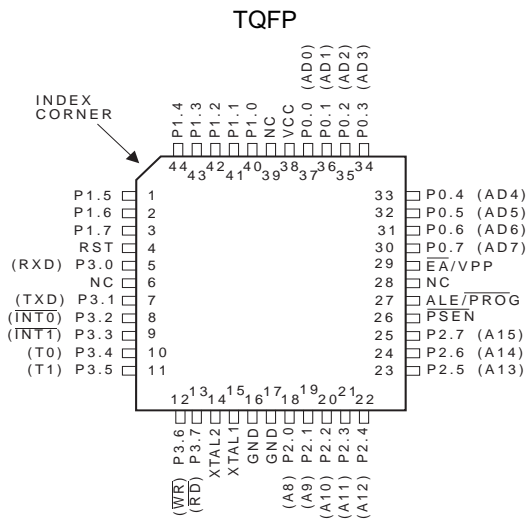

8-Bit Microcontroller with 4K Bytes Flash

AT89LV51

**Not Recommended
for New Designs.
Use AT89LS51.**

0303D-D-12/97



Block Diagram

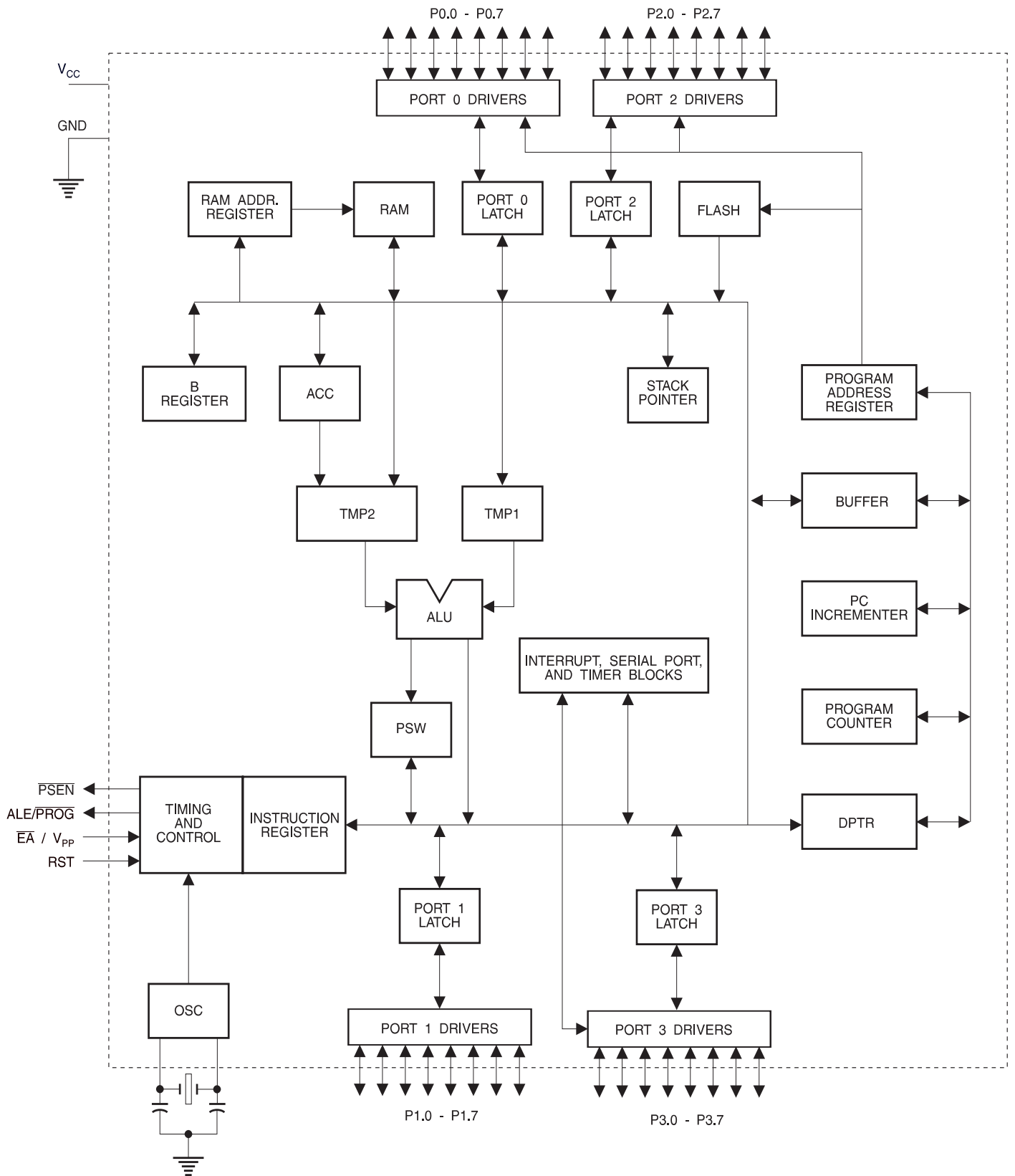

The AT89LV51 provides the following standard features: 4K bytes of Flash, 128 bytes of RAM, 32 I/O lines, two 16-bit timer/counters, a five vector two-level interrupt architecture, a full duplex serial port, on-chip oscillator and clock circuitry. In addition, the AT89LV51 is designed with static logic for operation down to zero frequency and supports two software selectable power saving modes. The Idle Mode stops the CPU while allowing the RAM, timer/counters, serial port and interrupt system to continue functioning. The Power Down Mode saves the RAM contents but freezes the oscillator disabling all other chip functions until the next hardware reset.

Pin Description

V_{CC}
Supply voltage.

GND
Ground.

Port 0
Port 0 is an 8-bit open drain bidirectional I/O port. As an output port each pin can sink eight TTL inputs. When 1s are written to port 0 pins, the pins can be used as high-impedance inputs.

Port 0 may also be configured to be the multiplexed low-order address/data bus during accesses to external program and data memory. In this mode P0 has internal pullups.

Port 0 also receives the code bytes during Flash programming, and outputs the code bytes during program verification. External pullups are required during program verification.

Port 1
Port 1 is an 8-bit bidirectional I/O port with internal pullups. The Port 1 output buffers can sink/source four TTL inputs. When 1s are written to Port 1 pins they are pulled high by the internal pullups and can be used as inputs. As inputs, Port 1 pins that are externally being pulled low will source current (I_{IL}) because of the internal pullups.

Port 1 also receives the low-order address bytes during Flash programming and verification.

Port 2
Port 2 is an 8-bit bidirectional I/O port with internal pullups. The Port 2 output buffers can sink/source four TTL inputs. When 1s are written to Port 2 pins they are pulled high by the internal pullups and can be used as inputs. As inputs, Port 2 pins that are externally being pulled low will source current (I_{IL}) because of the internal pullups.

Port 2 emits the high-order address byte during fetches from external program memory and during accesses to external data memory that use 16-bit addresses (MOVX @ DPTR). In this application it uses strong internal pullups

when emitting 1s. During accesses to external data memory that use 8-bit addresses (MOVX @ RI), Port 2 emits the contents of the P2 Special Function Register.

Port 2 also receives the high-order address bits and some control signals during Flash programming and verification.

Port 3
Port 3 is an 8-bit bidirectional I/O port with internal pullups. The Port 3 output buffers can sink/source four TTL inputs. When 1s are written to Port 3 pins they are pulled high by the internal pullups and can be used as inputs. As inputs, Port 3 pins that are externally being pulled low will source current (I_{IL}) because of the pullups.

Port 3 also serves the functions of various special features of the AT89LV51 as listed below:

Port Pin	Alternate Functions
P3.0	RXD (serial input port)
P3.1	TXD (serial output port)
P3.2	$\overline{\text{INT0}}$ (external interrupt 0)
P3.3	$\overline{\text{INT1}}$ (external interrupt 1)
P3.4	T0 (timer 0 external input)
P3.5	T1 (timer 1 external input)
P3.6	$\overline{\text{WR}}$ (external data memory write strobe)
P3.7	$\overline{\text{RD}}$ (external data memory read strobe)

Port 3 also receives some control signals for Flash programming and verification.

RST
Reset input. A high on this pin for two machine cycles while the oscillator is running resets the device.

ALE/PROG
Address Latch Enable output pulse for latching the low byte of the address during accesses to external memory. This pin is also the program pulse input (PROG) during Flash programming.

In normal operation ALE is emitted at a constant rate of 1/6 the oscillator frequency, and may be used for external timing or clocking purposes. Note, however, that one ALE pulse is skipped during each access to external Data Memory.

PSEN
Program Store Enable is the read strobe to external program memory.

When the AT89LV51 is executing code from external program memory, $\overline{\text{PSEN}}$ is activated twice each machine cycle, except that two $\overline{\text{PSEN}}$ activations are skipped during each access to external data memory.



\overline{EA}/V_{PP}

External Access Enable. \overline{EA} must be strapped to GND in order to enable the device to fetch code from external program memory locations starting at 0000H up to FFFFH. Note, however, that if lock bit 1 is programmed, \overline{EA} will be internally latched on reset.

\overline{EA} should be strapped to V_{CC} for internal program executions.

This pin also receives the 12-volt programming enable voltage (V_{PP}) during Flash programming, when 12-volt programming is selected.

XTAL1

Input to the inverting oscillator amplifier and input to the internal clock operating circuit.

XTAL2

Output from the inverting oscillator amplifier.

Special Function Registers

A map of the on-chip memory area called the Special Function Register (SFR) space is shown in Table 1.

Note that not all of the addresses are occupied, and unoccupied addresses may not be implemented on the chip. Read accesses to these addresses will in general return random data, and write accesses will have an indeterminate effect.

User software should not write 1s to these unlisted locations, since they may be used in future products to invoke new features. In that case, the reset or inactive values of the new bits will always be 0.

Timer 0 and 1

Timer 0 and Timer 1 in the AT89LV51 operate the same way as Timer 0 and Timer 1 in the AT89C51.

Table 1. AT89LV51 SFR Map and Reset Values

0F8H								0FFH
0F0H	B 00000000							0F7H
0E8H								0EFH
0E0H	ACC 00000000							0E7H
0D8H								0DFH
0D0H	PSW 00000000							0D7H
0C8H	T2CON 00000000	T2MOD XXXXXX00	RCAP2L 00000000	RCAP2H 00000000	TL2 00000000	TH2 00000000		0CFH
0C0H								0C7H
0B8H	IP XX000000							0BFH
0B0H	P3 11111111							0B7H
0A8H	IE 0X000000							0AFH
0A0H	P2 11111111							0A7H
98H	SCON 00000000	SBUF XXXXXXXX						9FH
90H	P1 11111111							97H
88H	TCON 00000000	TMOD 00000000	TL0 00000000	TL1 00000000	TH0 00000000	TH1 00000000		8FH
80H	P0 11111111	SP 00000111	DPL 00000000	DPH 00000000			PCON 0XXX0000	87H

Oscillator Characteristics

XTAL1 and XTAL2 are the input and output, respectively, of an inverting amplifier which can be configured for use as an on-chip oscillator, as shown in Figure 1. Either a quartz crystal or ceramic resonator may be used. To drive the device from an external clock source, XTAL2 should be left unconnected while XTAL1 is driven as shown in Figure 2. There are no requirements on the duty cycle of the external clock signal, since the input to the internal clocking circuitry is through a divide-by-two flip-flop, but minimum and maximum voltage high and low time specifications must be observed

Idle Mode

In idle mode, the CPU puts itself to sleep while all the on-chip peripherals remain active. The mode is invoked by software. The content of the on-chip RAM and all the special functions registers remain unchanged during this mode. The idle mode can be terminated by any enabled interrupt or by a hardware reset.

It should be noted that when idle is terminated by a hardware reset, the device normally resumes program execution, from where it left off, up to two machine cycles before the internal reset algorithm takes control. On-chip hardware inhibits access to internal RAM in this event, but access to the port pins is not inhibited. To eliminate the possibility of an unexpected write to a port pin when Idle is terminated by reset, the instruction following the one that invokes Idle should not be one that writes to a port pin or to external memory.

Power Down Mode

In the power down mode the oscillator is stopped, and the instruction that invokes power down is the last instruction executed. The on-chip RAM and Special Function Registers retain their values until the power down mode is terminated. The only exit from power down is a hardware reset. Reset redefines the SFRs but does not change the on-chip RAM. The reset should not be activated before V_{CC} is restored to its normal operating level and must be held active long enough to allow the oscillator to restart and stabilize.

Status of External Pins During Idle and Power Down Modes

Mode	Program Memory	ALE	$\overline{\text{PSEN}}$	PORT0	PORT1	PORT2	PORT3
Idle	Internal	1	1	Data	Data	Data	Data
Idle	External	1	1	Float	Data	Address	Data
Power Down	Internal	0	0	Data	Data	Data	Data
Power Down	External	0	0	Float	Data	Data	Data

Figure 1. Oscillator Connections

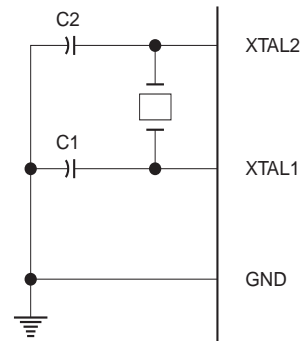

Note: C1, C2 = 30 pF ± 10 pF for Crystals
= 40 pF ± 10 pF for Ceramic Resonators

Figure 2. External Clock Drive Configuration

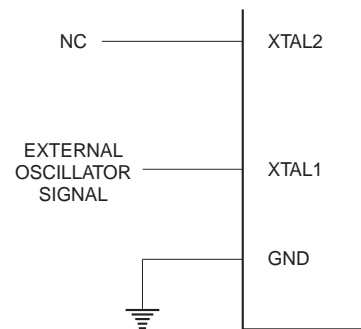

Program Memory Lock Bits

On the chip are three lock bits which can be left unprogrammed (U) or can be programmed (P) to obtain the additional features listed in the table below:

Lock Bit Protection Modes (1)

Program Lock Bits			Protection Type	
	LB1	LB2		LB3
1	U	U	U	No program lock features.
2	P	U	U	MOVC instructions executed from external program memory are disabled from fetching code bytes from internal memory, \overline{EA} is sampled and latched on reset, and further programming of the Flash is disabled.
3	P	P	U	Same as mode 2, also verify is disabled.
4	P	P	P	Same as mode 3, also external execution is disabled.

Note: 1. The lock bits can only be erased with the Chip Erase operation.

When lock bit 1 is programmed, the logic level at the \overline{EA} pin is sampled and latched during reset. If the device is powered up without a reset, the latch initializes to a random value, and holds that value until reset is activated. It is necessary that the latched value of \overline{EA} be in agreement with the current logic level at that pin in order for the device to function properly.

Programming the Flash

The AT89LV51 is normally shipped with the on-chip Flash memory array in the erased state (i.e. contents=FFH) and ready to be programmed.

The respective top-side marking and device signature codes are listed below:

$V_{PP} = 12V$	
Top-Side Mark	AT89LV51
	xxxx
	yyww
Signature	(030H) = 1EH
	(031H) = 61H
	(032H) = FFH

The AT89LV51 code memory array is programmed byte-by-byte. *To program any non-blank byte in the on-chip Flash Code Memory, the entire memory must be erased using the Chip Erase Mode.*

Programming Algorithm: Before programming the AT89LV51, the address, data and control signals should be set up according to the Flash programming mode table and Figure 3 and Figure 4. To program the AT89LV51, the following sequence should be followed:

1. Input the desired memory location on the address lines.
2. Input the appropriate data byte on the data lines.
3. Activate the correct combination of control signals.
4. Raise \overline{EA}/V_{PP} to 12V.
5. Pulse ALE/ \overline{PROG} once to program a byte in the Flash array or the lock bits. The byte-write cycle is self-timed and typically takes no more than 1.5 ms. Repeat steps 1 through 5 changing the address and data for the entire array or until the end of the object file is reached.

Data Polling: The AT89LV51 features \overline{Data} Polling to indicate the end of a write cycle. During a write cycle, an attempted read of the last byte written will result in the complement of the written data on PO.7. Once the write cycle has been completed, true data is valid on all outputs, and the next cycle may begin. \overline{Data} Polling may begin any time after a write cycle has been initiated.

Ready/Busy: The progress of byte programming can also be monitored by the RDY/ \overline{BSY} output signal. P3.4 is pulled low after ALE goes high during programming to indicate BUSY. P3.4 is pulled high again when programming is done to indicate READY.

Program Verify: If lock bits LB1 and LB2 have not been programmed, the programmed code data can be read back via the address and data lines for verification. The lock bits cannot be verified directly. Verification of the lock bits is achieved by observing that their features are enabled.

Chip Erase: The entire Flash array and the lock bits are erased electrically by using the proper combination of control signals and by holding ALE/ \overline{PROG} low for 10 ms. The code array is written with all "1"s. The chip erase operation must be executed before the code memory can be re-programmed.

Reading the Signature Bytes: The signature bytes are read by the same procedure as a normal verification of locations 030H and 031H, except that P3.6 and P3.7 need to be pulled to a logic low. The values returned are:

- (030H) = 1EH indicates manufactured by Atmel
- (031H) = 61H indicates 89LV51
- (032H) = FFH indicates 12V programming

Programming Interface

Every code byte in the Flash array can be written and the entire array can be erased by using the appropriate combination of control signals. The write operation cycle is self-timed and once initiated, will automatically time itself to completion.

All major programming vendors offer worldwide support for the Atmel microcontroller series. Please contact your local programming vendor for the appropriate software revision.

Flash Programming Modes

Mode	RST	$\overline{\text{PSEN}}$	ALE/ $\overline{\text{PROG}}$	$\overline{\text{EA}}/V_{\text{PP}}$	P2.6	P2.7	P3.6	P3.7
Write Code Data	H	L		12V	L	H	H	H
Read Code Data	H	L	H	H	L	L	H	H
Write Lock	H	L	Bit - 1	12V	H	H	H	H
			Bit - 2	12V	H	H	L	L
			Bit - 3	12V	H	L	H	L
Chip Erase	H	L	(1)	12V	H	L	L	L
Read Signature Byte	H	L	H	H	L	L	L	L

Note: 1. Chip Erase requires a 10-ms PROG pulse.

Figure 3. Programming the Flash

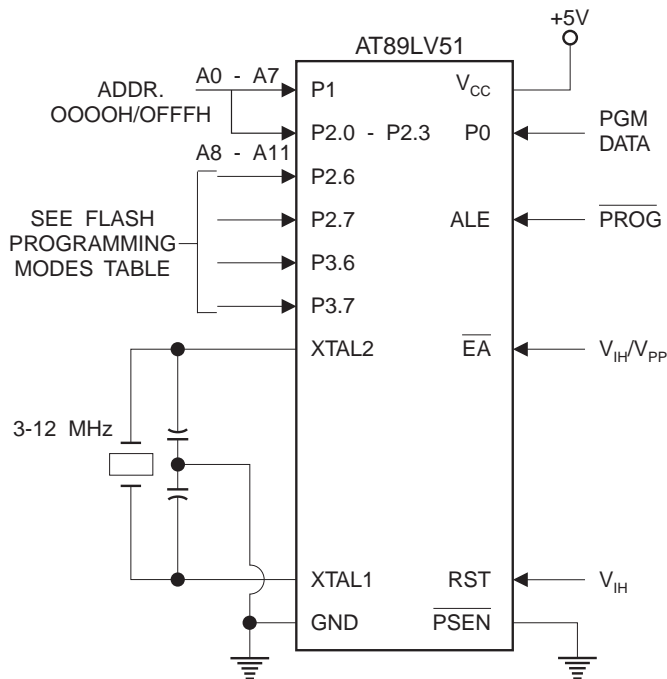
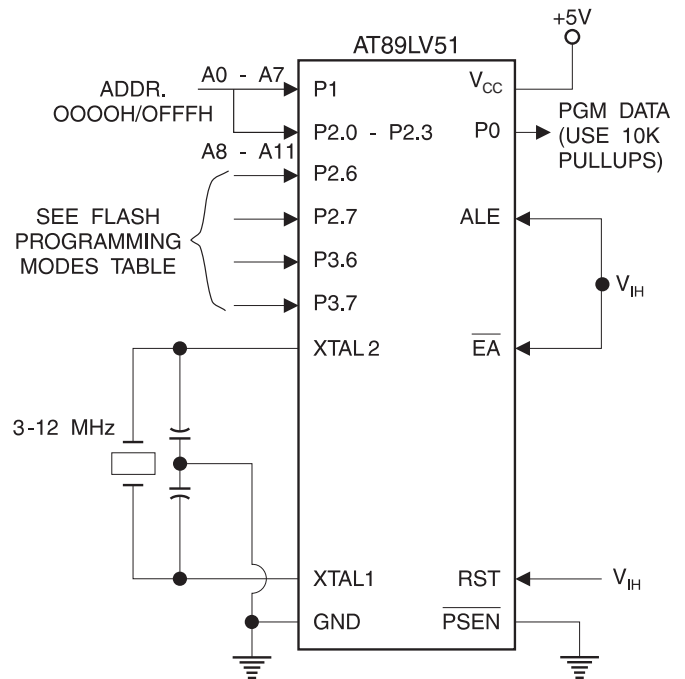

Figure 4. Verifying the Flash





Flash Programming and Verification Characteristics

$T_A = 0^\circ\text{C}$ to 70°C , $V_{CC} = 5.0\text{V} \pm 10\%$

Symbol	Parameter	Min	Max	Units
$V_{PP}^{(1)}$	Programming Enable Voltage	11.5	12.5	V
$I_{PP}^{(1)}$	Programming Enable Current		25	μA
$1/t_{CLCL}$	Oscillator Frequency	3	12	MHz
t_{AVGL}	Address Setup to $\overline{\text{PROG}}$ Low	$48t_{CLCL}$		
t_{GHAX}	Address Hold After $\overline{\text{PROG}}$	$48t_{CLCL}$		
t_{DVGL}	Data Setup to $\overline{\text{PROG}}$ Low	$48t_{CLCL}$		
t_{GHDX}	Data Hold After $\overline{\text{PROG}}$	$48t_{CLCL}$		
t_{EHS}	P2.7 ($\overline{\text{ENABLE}}$) High to V_{PP}	$48t_{CLCL}$		
t_{SHGL}	V_{PP} Setup to $\overline{\text{PROG}}$ Low	10		μs
$t_{GHSL}^{(1)}$	V_{PP} Hold After $\overline{\text{PROG}}$	10		μs
t_{GLGH}	$\overline{\text{PROG}}$ Width	1	110	μs
t_{AVQV}	Address to Data Valid		$48t_{CLCL}$	
t_{ELQV}	$\overline{\text{ENABLE}}$ Low to Data Valid		$48t_{CLCL}$	
t_{EHQZ}	Data Float After $\overline{\text{ENABLE}}$	0	$48t_{CLCL}$	
t_{GHBL}	$\overline{\text{PROG}}$ High to $\overline{\text{BUSY}}$ Low		1.0	μs
t_{WC}	Byte Write Cycle Time		2.0	ms

Note: 1. Only used in 12-volt programming mode.

Flash Programming and Verification Waveforms ($V_{PP} = 12V$)

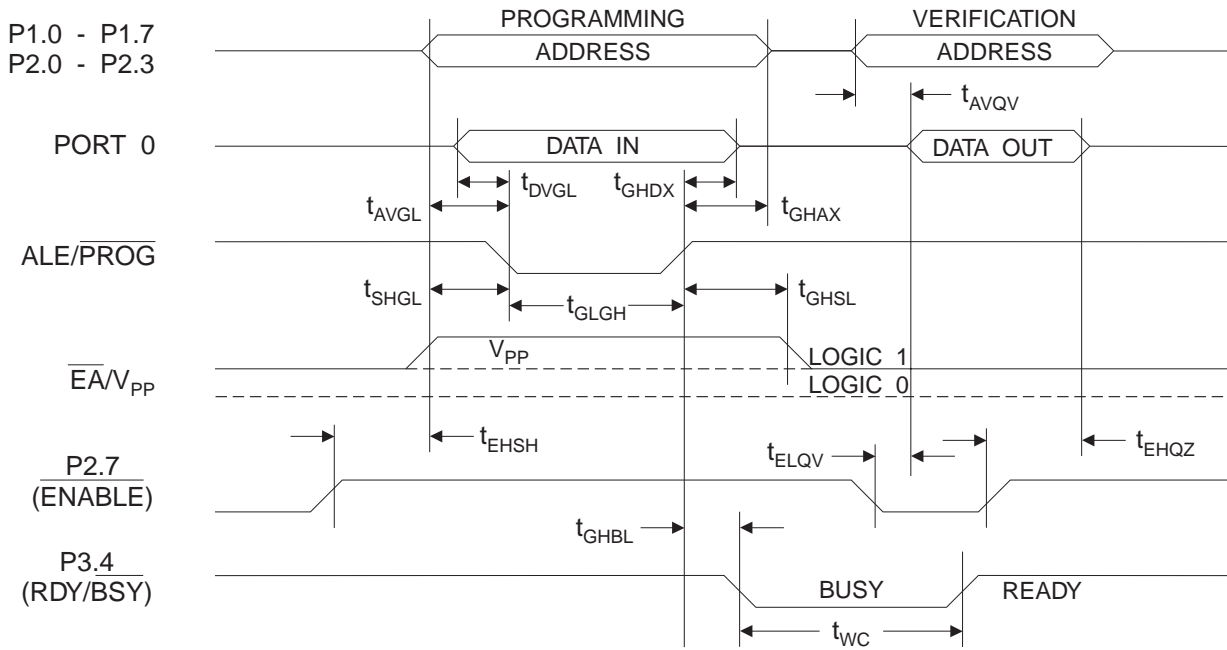



Absolute Maximum Ratings*

Operating Temperature.....	-55°C to +125°C
Storage Temperature	-65°C to +150°C
Voltage on Any Pin with Respect to Ground	-1.0V to +7.0V
Maximum Operating Voltage	6.6V
DC Output Current.....	15.0 mA

*NOTICE: Stresses beyond those listed under “Absolute Maximum Ratings” may cause permanent damage to the device. This is a stress rating only and functional operation of the device at these or any other conditions beyond those indicated in the operational sections of this specification is not implied. Exposure to absolute maximum rating conditions for extended periods may affect device reliability.

DC Characteristics

$T_A = -40^\circ\text{C}$ to 85°C , $V_{CC} = 2.7\text{V}$ to 6.0V (unless otherwise noted)

Symbol	Parameter	Condition	Min	Max	Units
V_{IL}	Input Low Voltage	(Except \overline{EA})	-0.5	$0.2 V_{CC} - 0.1$	V
V_{IL1}	Input Low Voltage (\overline{EA})		-0.5	$0.2 V_{CC} - 0.3$	V
V_{IH}	Input High Voltage	(Except XTAL1, RST)	$0.2 V_{CC} + 0.9$	$V_{CC} + 0.5$	V
V_{IH1}	Input High Voltage	(XTAL1, RST)	$0.7 V_{CC}$	$V_{CC} + 0.5$	V
V_{OL}	Output Low Voltage ⁽¹⁾ (Ports 1,2,3)	$I_{OL} = 1.6 \text{ mA}$		0.45	V
V_{OL1}	Output Low Voltage ⁽¹⁾ (Port 0, ALE, \overline{PSEN})	$I_{OL} = 3.2 \text{ mA}$		0.45	V
V_{OH}	Output High Voltage (Ports 1,2,3, ALE, \overline{PSEN})	$I_{OH} = -60 \mu\text{A}$, $V_{CC} = 5\text{V} \pm 10\%$	2.4		V
		$I_{OH} = -20 \mu\text{A}$	$0.75 V_{CC}$		V
		$I_{OH} = -10 \mu\text{A}$	$0.9 V_{CC}$		V
V_{OH1}	Output High Voltage (Port 0 in External Bus Mode)	$I_{OH} = -800 \mu\text{A}$, $V_{CC} = 5\text{V} \pm 10\%$	2.4		V
		$I_{OH} = -300 \mu\text{A}$	$0.75 V_{CC}$		V
		$I_{OH} = -80 \mu\text{A}$	$0.9 V_{CC}$		V
I_{IL}	Logical 0 Input Current (Ports 1,2,3)	$V_{IN} = 0.45\text{V}$		-50	μA
I_{TL}	Logical 1 to 0 Transition Current (Ports 1,2,3)	$V_{IN} = 2\text{V}$		-650	μA
I_{LI}	Input Leakage Current (Port 0, \overline{EA})	$0.45 < V_{IN} < V_{CC}$		± 10	μA
RRST	Reset Pulldown Resistor		50	300	$\text{K}\Omega$
C_{IO}	Pin Capacitance	Test Freq. = 1 MHz, $T_A = 25^\circ\text{C}$		10	pF
I_{CC}	Power Supply Current	Active Mode, 12 MHz, $V_{CC} = 6\text{V}/3\text{V}$		20/5.5	mA
		Idle Mode, 12 MHz, $V_{CC} = 6\text{V}/3\text{V}$		5/1	mA
	Power Down Mode ⁽²⁾	$V_{CC} = 6\text{V}$		100	μA
		$V_{CC} = 3\text{V}$		20	μA

Notes: 1. Under steady state (non-transient) conditions, I_{OL} must be externally limited as follows:
 Maximum I_{OL} per port pin: 10 mA
 Maximum I_{OL} per 8-bit port:
 Port 0: 26 mA
 Ports 1, 2, 3: 15 mA

Maximum total IOL for all output pins: 71mA
 If I_{OL} exceeds the test condition, V_{OL} may exceed the related specification. Pins are not guaranteed to sink current greater than the listed test conditions.

2. Minimum V_{CC} for Power Down is 2V.

AC Characteristics

Under operating conditions, load capacitance for Port 0, ALE/ $\overline{\text{PROG}}$, and $\overline{\text{PSEN}}$ = 100 pF; load capacitance for all other outputs = 80 pF.

External Program and Data Memory Characteristics

Symbol	Parameter	12 MHz Oscillator		Variable Oscillator		Units
		Min	Max	Min	Max	
$1/t_{\text{CLCL}}$	Oscillator Frequency			0	12	MHz
t_{LHLL}	ALE Pulse Width	127		$2t_{\text{CLCL}}-40$		ns
t_{AVLL}	Address Valid to ALE Low	43		$t_{\text{CLCL}}-40$		ns
t_{LLAX}	Address Hold After ALE Low	48		$t_{\text{CLCL}}-35$		ns
t_{LLIV}	ALE Low to Valid Instruction In		233		$4t_{\text{CLCL}}-100$	ns
t_{LLPL}	ALE Low to $\overline{\text{PSEN}}$ Low	43		$t_{\text{CLCL}}-40$		ns
t_{PLPH}	$\overline{\text{PSEN}}$ Pulse Width	205		$3t_{\text{CLCL}}-45$		ns
t_{PLIV}	$\overline{\text{PSEN}}$ Low to Valid Instruction In		145		$3t_{\text{CLCL}}-105$	ns
t_{PXIX}	Input Instruction Hold After $\overline{\text{PSEN}}$	0		0		ns
t_{PXIZ}	Input Instruction Float After $\overline{\text{PSEN}}$		59		$t_{\text{CLCL}}-25$	ns
t_{PXAV}	$\overline{\text{PSEN}}$ to Address Valid	75		$t_{\text{CLCL}}-8$		ns
t_{AVIV}	Address to Valid Instruction In		312		$5t_{\text{CLCL}}-105$	ns
t_{PLAZ}	$\overline{\text{PSEN}}$ Low to Address Float		10		10	ns
t_{RLRH}	$\overline{\text{RD}}$ Pulse Width	400		$6t_{\text{CLCL}}-100$		ns
t_{WLWH}	$\overline{\text{WR}}$ Pulse Width	400		$6t_{\text{CLCL}}-100$		ns
t_{RLDV}	$\overline{\text{RD}}$ Low to Valid Data In		252		$5t_{\text{CLCL}}-165$	ns
t_{RHDX}	Data Hold After $\overline{\text{RD}}$	0		0		ns
t_{RHDZ}	Data Float After $\overline{\text{RD}}$		97		$2t_{\text{CLCL}}-70$	ns
t_{LLDV}	ALE Low to Valid Data In		517		$8t_{\text{CLCL}}-150$	ns
t_{AVDV}	Address to Valid Data In		585		$9t_{\text{CLCL}}-165$	ns
t_{LLWL}	ALE Low to $\overline{\text{RD}}$ or $\overline{\text{WR}}$ Low	200	300	$3t_{\text{CLCL}}-50$	$3t_{\text{CLCL}}+50$	ns
t_{AVWL}	Address to $\overline{\text{RD}}$ or $\overline{\text{WR}}$ Low	203		$4t_{\text{CLCL}}-130$		ns
t_{QVWX}	Data Valid to $\overline{\text{WR}}$ Transition	23		$t_{\text{CLCL}}-60$		ns
t_{QVWH}	Data Valid to $\overline{\text{WR}}$ High	433		$7t_{\text{CLCL}}-150$		ns
t_{WHQX}	Data Hold After $\overline{\text{WR}}$	33		$t_{\text{CLCL}}-50$		ns
t_{RLAZ}	$\overline{\text{RD}}$ Low to Address Float		0		0	ns
t_{WHLH}	$\overline{\text{RD}}$ or $\overline{\text{WR}}$ High to ALE High	43	123	$t_{\text{CLCL}}-40$	$t_{\text{CLCL}}+40$	ns

External Program Memory Read Cycle

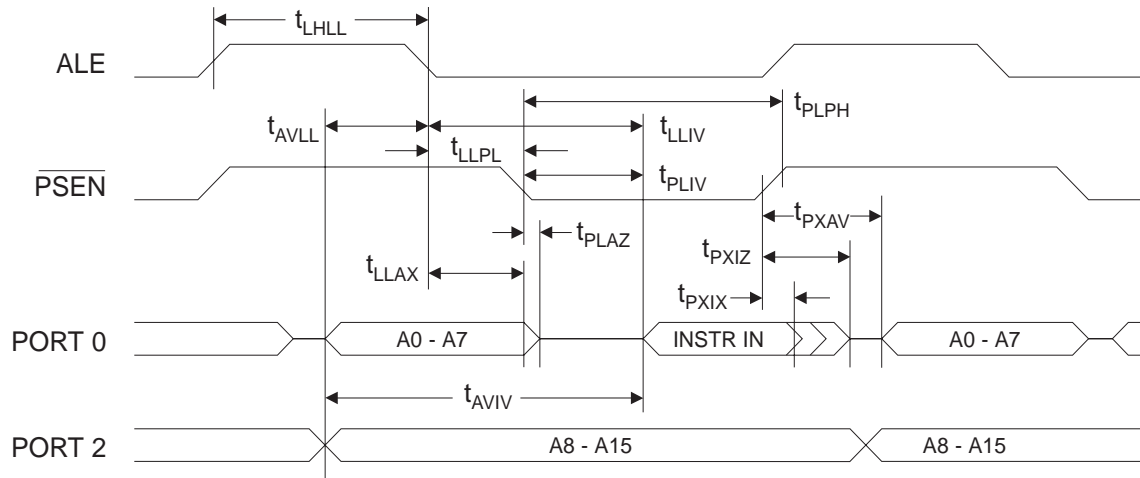

External Data Memory Read Cycle

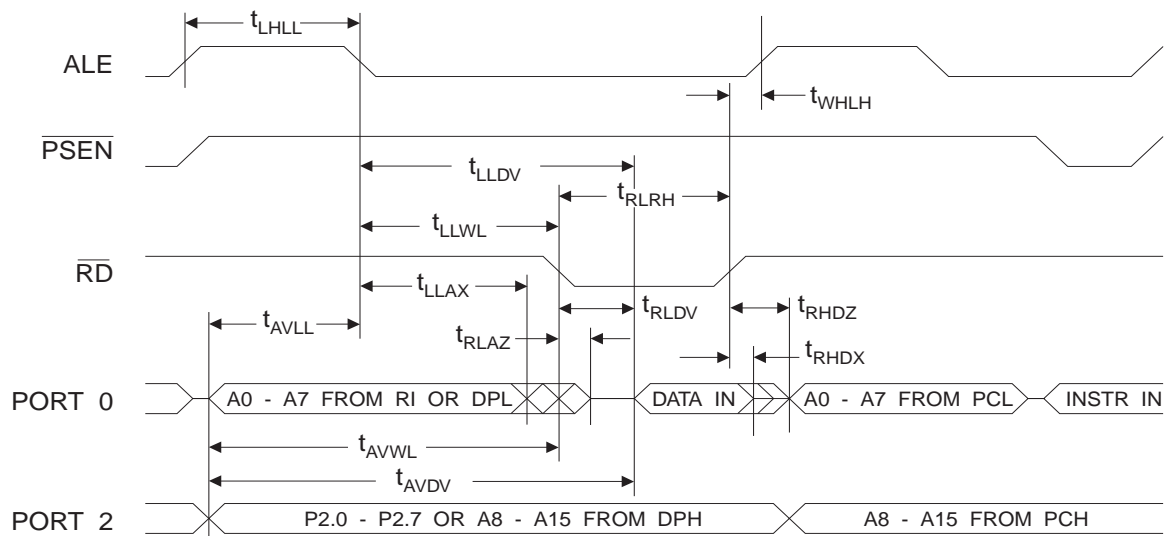

External Data Memory Write Cycle

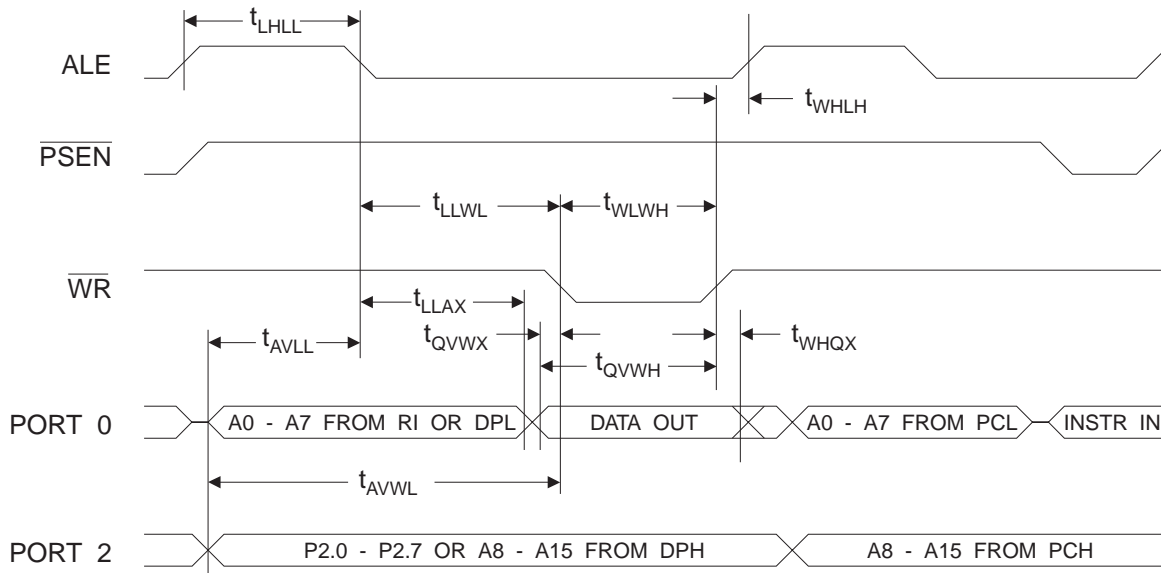

External Clock Drive Waveforms

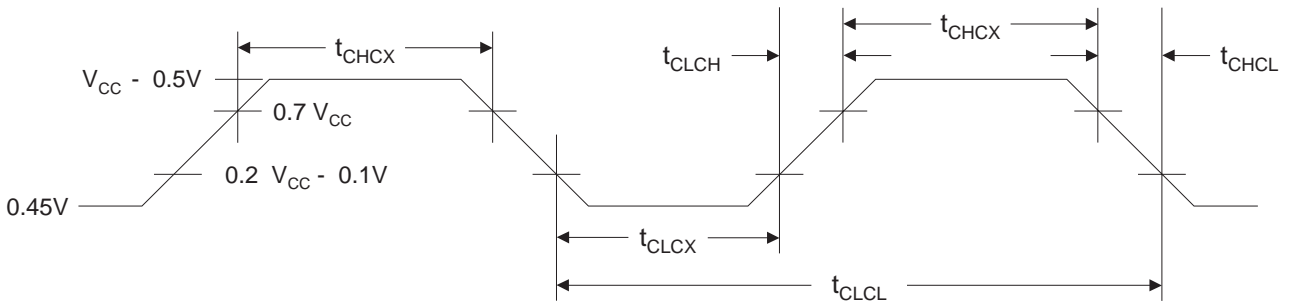

External Clock Drive

Symbol	Parameter	Min	Max	Units
1/t _{CLCL}	Oscillator Frequency	0	12	MHz
t _{CLCL}	Clock Period	83.3		ns
t _{CHCX}	High Time	20		ns
t _{CLCX}	Low Time	20		ns
t _{CLCH}	Rise Time		20	ns
t _{CHCL}	Fall Time		20	ns

Serial Port Timing: Shift Register Mode Test Conditions

($V_{CC} = 2.7V$ to $6V$; Load Capacitance = 80 pF)

Symbol	Parameter	12 MHz Osc		Variable Oscillator		Units
		Min	Max	Min	Max	
t_{XLXL}	Serial Port Clock Cycle Time	1.0		$12t_{CLCL}$		μs
t_{QVXH}	Output Data Setup to Clock Rising Edge	700		$10t_{CLCL}-133$		ns
t_{XHGX}	Output Data Hold After Clock Rising Edge	50		$2t_{CLCL}-117$		ns
t_{XHDX}	Input Data Hold After Clock Rising Edge	0		0		ns
t_{XHDX}	Clock Rising Edge to Input Data Valid		700		$10t_{CLCL}-133$	ns

Shift Register Mode Timing Waveforms

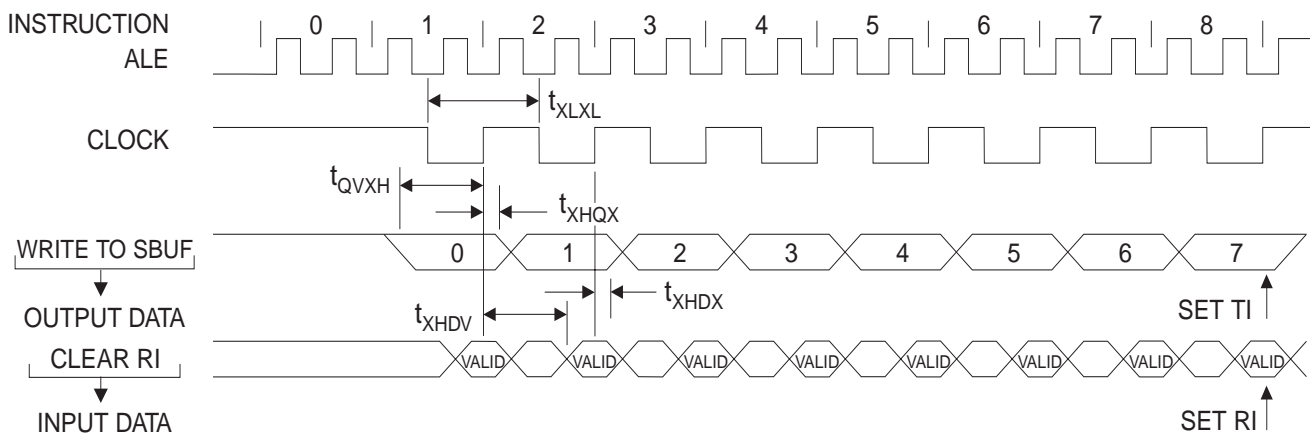

AC Testing Input/Output Waveforms (1)

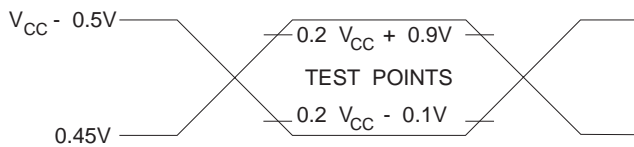

Note: 1. AC inputs during testing are driven at $2.4V$ for a logic "1" and $0.45V$ for a logic "0". Timing measurements are made at $2.0V$ for a logic "1" and $0.8V$ for a logic "0".

Float Waveforms (1)

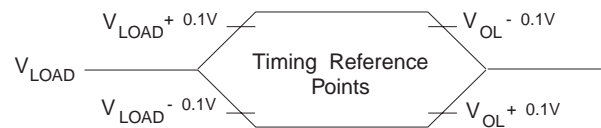

Note: 1. For timing purposes, a port pin is no longer floating when a 100 mV change from load voltage occurs. A port pin begins to float when a 100 mV change from the loaded V_{OH}/V_{OL} level occurs.

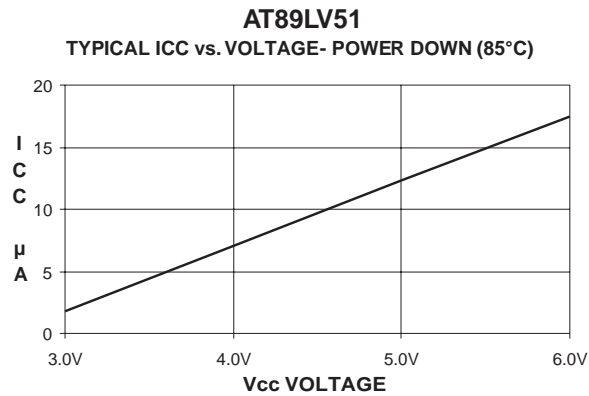
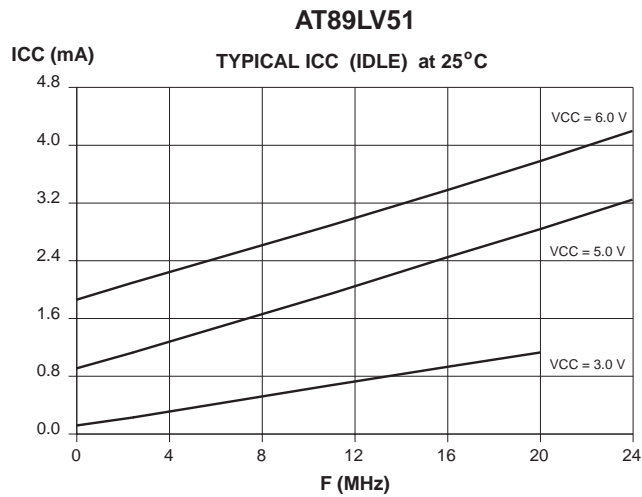
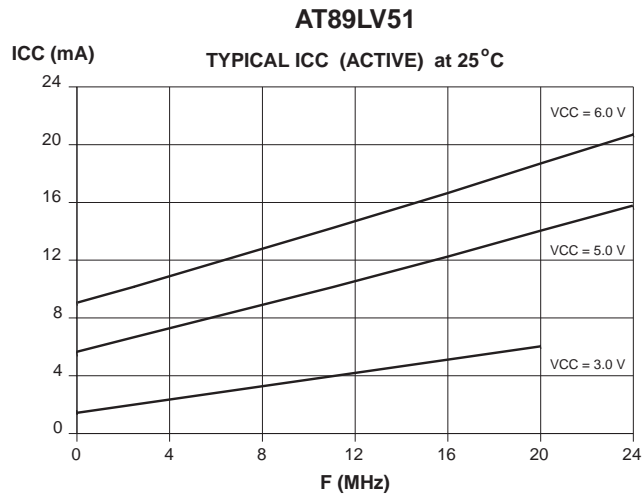

- Notes:
1. XTAL1 tied to GND for I_{CC} (power down)
 2. Lock bits programmed





Ordering Information

Speed (MHz)	Power Supply	Ordering Code	Package	Operation Range
12	2.7V to 6V	AT89LV51-12AC AT89LV51-12JC AT89LV51-12PC	44A 44J 40P6	Commercial (0° C to 70° C)
12	2.7V to 6V	AT89LV51-12AI AT89LV51-12JI AT89LV51-12PI	44A 44J 40P6	Industrial (-40° C to 85° C)

Package Type	
44A	44 Lead, Thin Plastic Gull Wing Quad Flatpack (TQFP)
44J	44 Lead, Plastic J-Leaded Chip Carrier (PLCC)
40P6	40 Lead, 0.600" Wide, Plastic Dull Inline Package (PDIP)

This datasheet has been download from:

www.datasheetcatalog.com

Datasheets for electronics components.