

**PRELIMINARY**  
 Notice ; This is not a final specification.  
 some parametric limits are subject to change.

MITSUBISHI SOUND PROCESSORS

# M61504FP

DIGITAL SOUND CONTROLLER WITH SURROUND

## DESCRIPTION

The M61504FP is an optimum digital sound controller IC for home audio.

It has a 4ch input selector, input volume, surround (3 variation), tone control (3 band), loudness, Vocal cut and 2ch master volume.

It can control all of these function with serial data.

## FEATURES

- Built-in 4ch input selector.
- Built-in input volume (2dB step/3 bit)
- IC for Dolby-pro-logic Interface.
- Built-in Surround (ON/OFF,High/Middle/Low <3 variation>)
- Tone control (Bass/Mid/Treble)
- Built-in Loudness.
- Vocal cut (Surround OFF setting only)
- Main Volume (36 step 0 to -80dB,- )
- Microcomputer Interface.

## PACKAGE

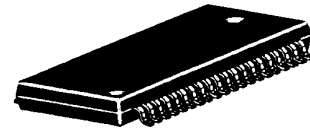

Outline 42P2R-A

0.8mm Pitch 450mil SSOP  
 (8.4mm x 17.5mm x 2.0mm)

## RECOMMENDED OPERATING CONDITIONS

Supply voltage range ....Vcc= 4.5~5.5    Rated supply voltage....Vcc=5V

## SYSTEM CONFIGURATION

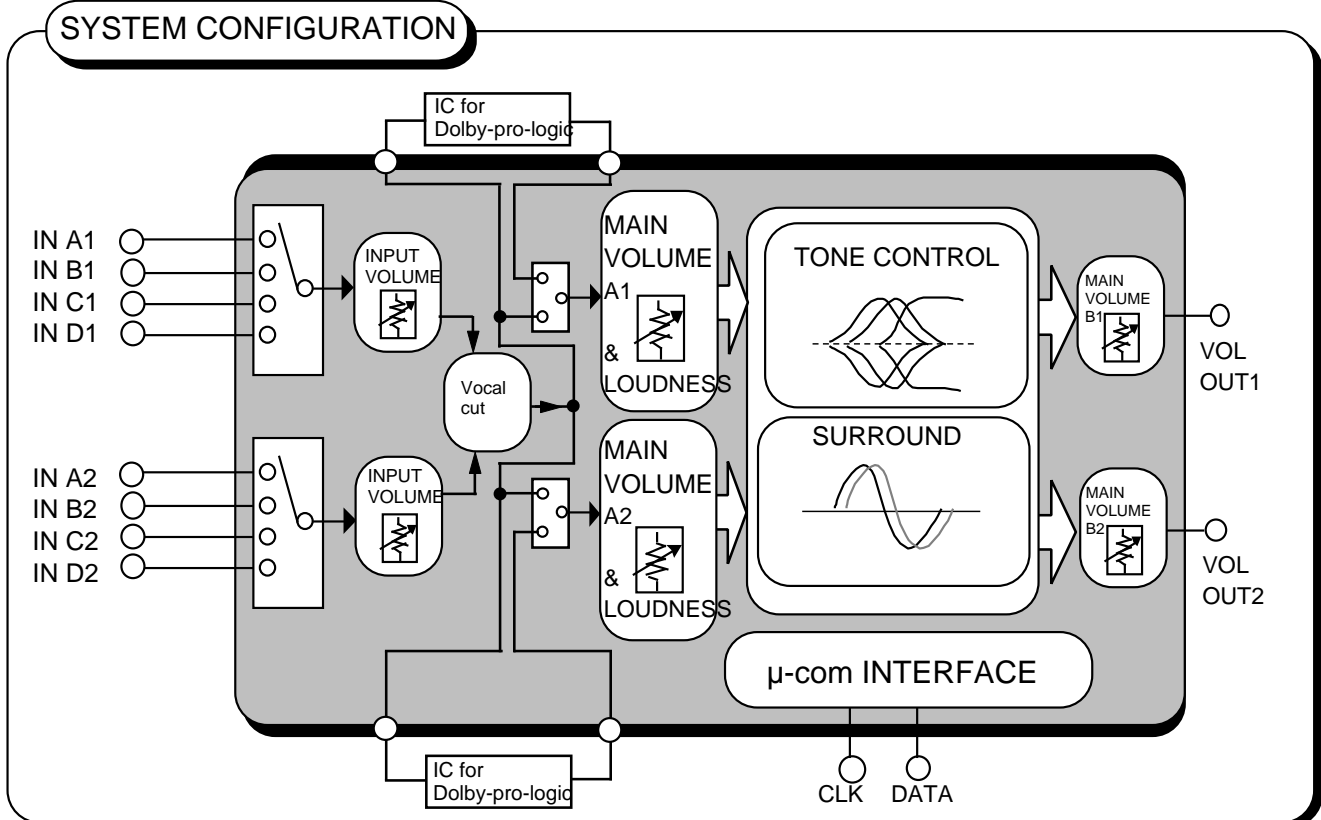

**PRELIMINARY**  
 Notice ; This is not a final specification.  
 some parametric limits are subject to change.

MITSUBISHI SOUND PROCESSORS

# M61504FP

DIGITAL SOUND CONTROLLER WITH SURROUND

## PIN CONFIGURATION AND IC INTERNAL BLOCK DIAGRAM

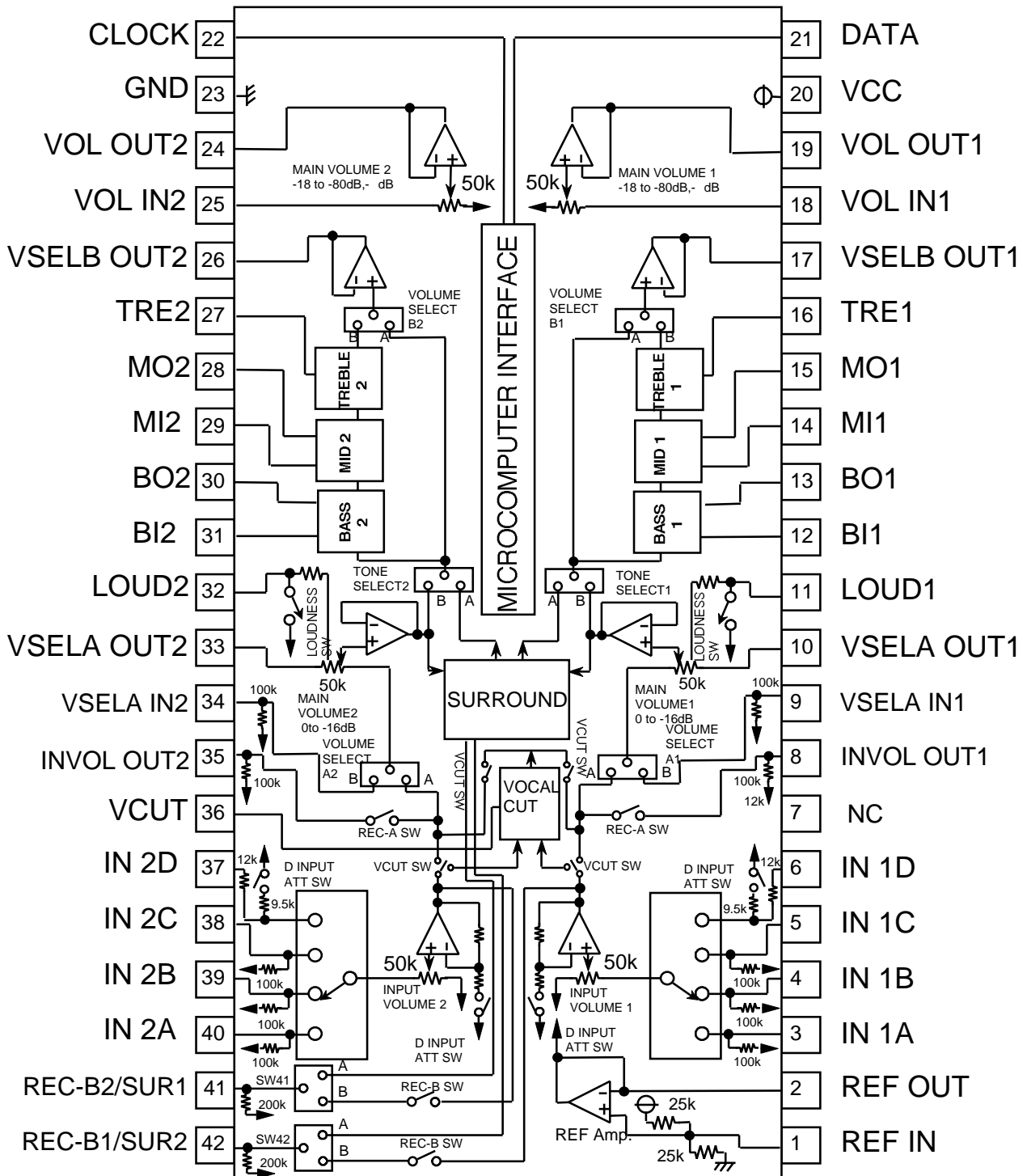

**PRELIMINARY**  
 Notice ; This is not a final specification.  
 some parametric limits are subject to change.

MITSUBISHI SOUND PROCESSORS

# M61504FP

## DIGITAL SOUND CONTROLLER WITH SURROUND

### PIN DESCRIPTION

Pin No.	Symbol	Function
1	REF IN	Input pin of reference Amp.
2	REF OUT	Output pin of the reference Amp.
3,4,5,6, 37,38,39,40	IN 1A,1B,1C,1D, 2A,2B,2C,2D	Input pin of the input selector Ch1 and Ch2
8,35	INVOL OUT1,2	Output pin of the input volume 1 and 2
9,34	VSELA IN1,2	Input pin of the volume input selector A1 and A2
10,33	VSELA OUT1,2	Capacitor connection pin for the volume changing noise reduction
11,32	LOUD1,2	Frequency characteristic setting pin in the loudness part
12,31	BI1,2	Frequency characteristic setting pin in the tone control (Bass).
13,30	BO1,2	
14,29	MI1,2	Frequency characteristic setting pin in the tone control (Mid).
15,28	MO1,2	
16,27	TRE1,2	Frequency characteristic setting pin in the tone control (Treble).
17,26	VSELB OUT1,2	Output pin of the volume input selector B1 and B2
18,25	VOL IN1,2	Input pin of the main volume
19,24	VOL OUT1,2	Output pin of the main volume
20	VCC	The power supply
21	DATA	Input pin of the serial data
22	CLOCK	Clock input pin for the serial data forwarding
23	GND	GND
36	VCUT	Capacitor for vocal cut Impedance (band filter) connection pin
41	REC-B2/SUR1	Output pin of the REC-B2/Device connection pin for the surround external parts
42	REC-B1/SUR2	Output pin of the REC-B1/Device connection pin for the surround external parts
7	NC	Non connection

**PRELIMINARY**  
 Notice ; This is not a final specification.  
 some parametric limits are subject to change.

MITSUBISHI SOUND PROCESSORS

# M61504FP

## DIGITAL SOUND CONTROLLER WITH SURROUND

### ABSOLUTE MAXIMUM RATINGS

Symbol	Parameter	Conditions	Limits	Units
VCC	Supply voltage		6.0	V
Pd	Power dissipation	Ta 25°C	960	mW
K	Thermal derating	Ta>25°C	9.6	mW/°C
Topr	Operating temperature		-20 to +75	°C
Tstg	Storage temperature		-40 to +125	°C

### THERMAL DERATING

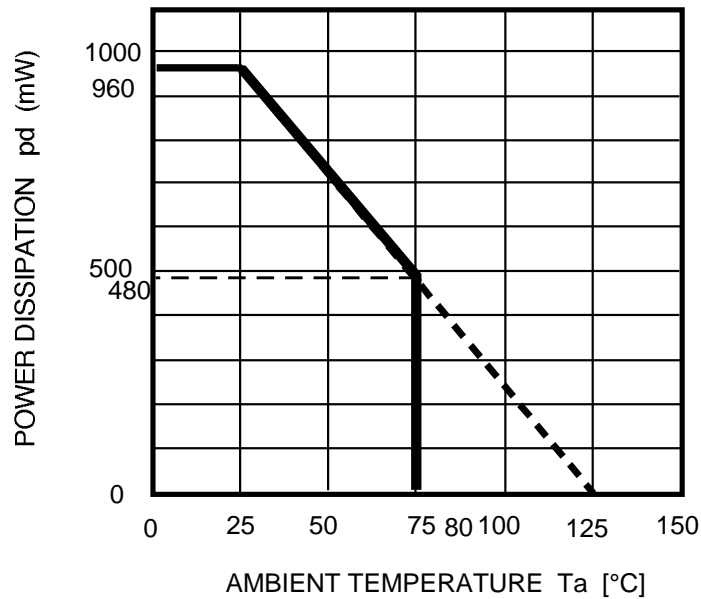

**PRELIMINARY**  
 Notice ; This is not a final specification.  
 some parametric limits are subject to change.

MITSUBISHI SOUND PROCESSORS

# M61504FP

## DIGITAL SOUND CONTROLLER WITH SURROUND

### RECOMMENDED OPERATING CONDITION

(Ta=25°C, unless otherwise noted)

Parameter	Symbol	Conditions	MIN	TYP	MAX	Units
Supply voltage	VCC		4.5	5.0	5.5	V
Logic"H"level input voltage	VIH	GND reference	2.4	—	VCC	V
Logic"L"level input voltage	VIL	GND reference	GND	—	0.7	V

### RELATIONSHIP BETWEEN DATA AND CLOCK

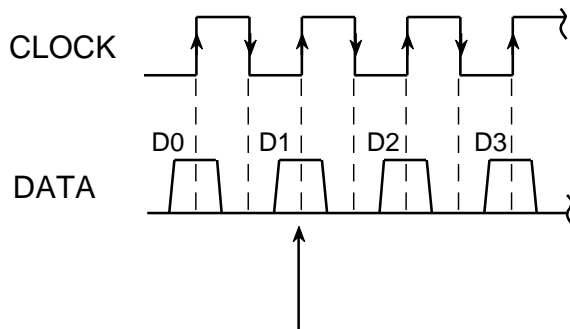

Data signal is read at the rising edge of clock.

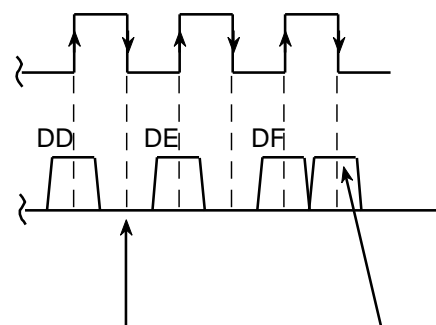

Signal is latched at the rising edge of the latch signal.

Latch signal: H

**PRELIMINARY**  
 Notice ; This is not a final specification.  
 some parametric limits are subject to change.

MITSUBISHI SOUND PROCESSORS

# M61504FP

## DIGITAL SOUND CONTROLLER WITH SURROUND

### DATA CONTROL SPECIFICATION

For kinds of input format options are available by changing slot settings of DC,DD.

(When the IC is powered up,the internal setting are not fixed.)

<MUTE cancellation data> (x is optional setting)

D04 D14 D24 **D34** D44 **D54** D64 D74 D84 D94 DA4 DB4 **DC** **DD** **DE** **DF**  
 X X X **0** X **1** X X X X X X **1** **1** **0** **0**

Tip address

(1)	D01	D11	D21	D31	D41	D51	D61	D71	D81	D91	DA1	DB1	DC	DD	DE	DF
	TONE CONTROL TREBLE				TONE CONTROL MID				TONE CONTROL BASS				0	0	0	0

(2)	DO2	D12	D22	D32	D42	D52	D62	D72	D82	D92	DA2	DB2	DC	DD	DE	DF
	A1 VOLUME CH 1				B1 VOLUME CH 1				INPUT D ATT SW	0	Note3) VOCAL CUT	0	1	0	0	

(3)	DO3	D13	D23	D33	D43	D53	D63	D73	D83	D93	DA3	DB3	DC	DD	DE	DF
	A1 VOLUME CH 2				B1 VOLUME CH2				LOUDNESS SW	TONE INPUT SELECTOR	D Input ATT SW -5/-8dB	1	0	0	0	

(4)

Note1)

	DO4	D14	D24	D34	D44	D54	D64	D74	D84	D94	DA4	DB4	DC	DD	DE	DF
SURROUND OF OUTSIDE SETTING	INPUT SELECTOR			Note) Mute	REC-B ON:1 OFF:0	1	INPUT VOLUME			A INPUT VOLUME SELECTOR	B INPUT VOLUME SELECTOR	REC-A ON:1 OFF:0	1	1	0	0
SURROUND OF INSIDE SETTING				Note3) SURROUND	0											

Note1) Surround of outside setting, it becomes "D54=1"--->Sw41 and 42 setting = B fixation. Surround of inside setting ( Surround of outside non setting), It becomes "D54=0"--->Sw41 and 42 setting = A fixation.

Note2) In power supply investing to Mute an output in, It becomes setting like the following. Input selector = ALL OFF, Outside surround mode setting, REC-A,B SW=OFF,B1 main volume= - setting. The similar MUTE setting can be done by setting D34=D54=1.

Note3) It is impossible to use the vocal cut and the inside surround function, First. it sets the vocal cut ON after setting the inside surround ON, in case of switching to the vocal cut ON setting from the inside surround ON setting. And it sets the inside surround ON after setting the vocal cut On, in case of switching to the inside surround ON setting from the vocal cut ON setting.

**PRELIMINARY**  
 Notice ; This is not a final specification.  
 some parametric limits are subject to change.

MITSUBISHI SOUND PROCESSORS

# M61504FP

## DIGITAL SOUND CONTROLLER WITH SURROUND

### SETTING CODE

(1)TONE CONTROL (TREBLE/MID/BASS)

ATT	TREBLE	D01	D11	D21	D31
	MID	D41	D51	D61	D71
	BASS	D81	D91	DA1	DB1
+ 8dB		1	1	0	0
+ 6dB		1	0	1	1
+ 4dB		1	0	1	0
+ 2dB		1	0	0	1
0dB		0	0	0	0
- 2dB		0	0	0	1
- 4dB		0	0	1	0
- 6dB		0	0	1	1
- 8dB		0	1	0	0

(8)INPUT SELECTOR

INPUT	D04	D14	D24
A ch	0	0	0
B ch	0	0	1
C ch	0	1	0
D ch	0	1	1
E ch	1	0	0
ALL OFF	1	1	1

(2)LOUDNESS

LOUDNESS	D93
OFF	0
ON	1

(3)A VOL SELECTOR

A VOL SELECTOR	D94
BYPASS	0
OUTSIDE SURROUND INPUT	1

(9) REC-A SWITCH

REC-A OUTPUT	DB4
OFF	0
ON	1

(4)B VOL SELECTOR

BVOL SELECTOR	DA4
BYPASS	0
TONE	1

(5)TONE INPUT SELECTOR

TONE INPUT	DA3
BYPASS	0
INSIDE SURROUND INPUT	1

(10)SURROUND

Note) It is possible to control only at D54="0" setting.

SURROUND	D34	D44
OFF	0	0
L	1	0
M	0	1
H	1	1

(6) D INPUT ATT SW

E INPUT ATT SW	DA2
0dB	0
-5/-8dB	1

(7) VOCAL CUT SW

VOCAL CUT SW	DB2
OFF	0
ON	1

(11)INPUT VOLUME

INPUT VOLUME	D64	D74	D84
0 dB	0	0	0
-2 dB	0	0	1
-4 dB	0	1	0
-6 dB	0	1	1
-8 dB	1	0	0
-10 dB	1	0	1
-12 dB	1	1	0
-14 dB	1	1	1

(8) D INPUT ATT SW

D/E INPUT ATT SW	DB3
-8dB	0
-5dB	1

Note:Do not input other data than the above.

**PRELIMINARY**  
 Notice ; This is not a final specification.  
 some parametric limits are subject to change.

MITSUBISHI SOUND PROCESSORS

# M61504FP

## DIGITAL SOUND CONTROLLER WITH SURROUND

### (12)A MAIN VOLUME

A T T	FRONT STEP VOL. CH 1	D02	D12	D22	D32
	FRONT STEP VOL. CH 2	D03	D13	D23	D33
	0 dB	0	0	0	0
	-2 dB	0	0	0	1
	-4 dB	0	0	1	0
	-6 dB	0	0	1	1
	-8 dB	0	1	0	0
	-10 dB	0	1	0	1
	-12 dB	0	1	1	0
	-14 dB	0	1	1	1
	-16 dB	1	0	0	0

### (13)B MAIN VOLUME

A T T	BACK STEP VOL. CH 1	D42	D52	D62	D72	D82
	BACK STEP VOL. CH 2	D43	D53	D63	D73	D83
	0 dB	0	0	0	0	0
	-2 dB	0	0	0	0	1
	-4 dB	0	0	0	1	0
	-6 dB	0	0	0	1	1
	-8 dB	0	0	1	0	0
	-10 dB	0	0	1	0	1
	-12 dB	0	0	1	1	0
	-14 dB	0	0	1	1	1
	-16 dB	0	1	0	0	0
	-18 dB	0	1	0	0	1
	-20 dB	0	1	0	1	0
	-22 dB	0	1	0	1	1
	-24 dB	0	1	1	0	0
	-26 dB	0	1	1	0	1
	-28 dB	0	1	1	1	0
	-32 dB	0	1	1	1	1
	-36 dB	1	0	0	0	0
	-40 dB	1	0	0	0	1
	-44 dB	1	0	0	1	0
	-48 dB	1	0	0	1	1
	-52 dB	1	0	1	0	0
	-56 dB	1	0	1	0	1
	-60 dB	1	0	1	1	0
	-61 dB	1	0	1	1	1
	-62 dB	1	1	0	0	0
	-63 dB	1	1	0	0	1
	-64 dB	1	1	0	1	0
	- dB	1	1	1	1	1

**PRELIMINARY**  
 Notice ; This is not a final specification.  
 some parametric limits are subject to change.

MITSUBISHI SOUND PROCESSORS

# M61504FP

## DIGITAL SOUND CONTROLLER WITH SURROUND

### ELECTRICAL CHARACTERISTICS

(Ta=25°C, VCC=5.0V, f=1kHz, unless otherwise noted.)

INPUT VOLUME=0dB, SURROUND, LOUDNESS=OFF, VOL. INPUT SELECTOR A, B  
 setting=Bypass, TONE INPUT SELECTOR=Bypass. Refer to the application circuit example.)

#### (1) Power supply characteristics

Parameter	Symbol	Test condition	Limits			Units
			MIN	TYP	MAX	
Circuit current	Aldd	No signal setting	—	35	60	mA

#### (2) Input/Output characteristics (Total) Ta=25°C

Parameter	Symbol	Test condition	Limits			Units
			MIN	TYP	MAX	
Input impedance	Rin	3~5pin, 38~40pin	22	33	48	K
Maximum input Amplitude	VIMt	(Input pin to 3~5, 38~40) Output pin to 19, 24, A main Vol=-2dB RL=10K , THD=1%	1.2	1.4	—	Vrms
	VIMtD	(Input pin to 6, 37) Output pin to 19, 24 RL=10 , THD=1% D, Ech ATT SW=-8dB, Input VOL=-2dB	2.8	3.1	—	Vrms
Maximum output Amplitude	VOMt	(Input pin~3, 40) Output pin to 19, 24 RL=10 , THD=1%	1.0	1.25	—	Vrms
Gain	Gvt	Vi=0.5Vrms, FLAT, Pin(3~6, 37~40pin)-19, 24gains	-2.0	0	2.0	dB
Total harmonic distortion	THDA	(Input pin to 3, 40) Output pin to 19, 24 DIN-AUDIO, Vi=0.5Vrms , RL=30	—	0.006	0.07	%
	THDB	B Volume input selector THDA: Bypass THDB: Tone	—	0.009	0.09	%
Output noise level	NoA	19, 24pin, Rg=0 , JIS-A, Main volume=-	—	2.5	6	μVrms
		19, 24pin, Rg=0 , JIS-A, Main volume=0dB	—	5	10	μVrms
	NoB	19, 24pin, Rg=0 , JIS-A, B Volume input selector: Tone	—	7	15	μVrms
		19, 24pin, Rg=0 , JIS-A, B Volume input select: Tone, Tone input select: Surround	—	10	20	μVrms
Cross talk between channels	CT	Vo=0.5Vrms , RL=10K , JIS-A Pin 19 to 24gains Rg=10K	—	-80	-65	dB
Volume maximum attenuation quantity	ATTmax	Vi=1Vrms , JIS-A Main volume= -	—	—	-80	dB

**PRELIMINARY**  
 Notice ; This is not a final specification.  
 some parametric limits are subject to change.

MITSUBISHI SOUND PROCESSORS

# M61504FP

## DIGITAL SOUND CONTROLLER WITH SURROUND

### (3)Tone control characteristics

Vi=0.2Vrms, Input pin to 9 and 34, Output pin to 17 and 26, A VOL input selector: Input to outside surround, Tone input selector: Bypass, B VOL input selector: Tone, unless otherwise noted.

Parameter	Symbol	Test conditions	Limits			Units
			MIN	TYP	MAX	
Value of Boost(Bass)	G(BASS)B	f=100Hz Tone bass setting +8dB	6	8	10	dB
Value of Cut(Bass)	G(BASS)C	f=100Hz Tone bass setting -8dB	-10	-8	-6	dB
Value of Boost(Mid)	G(MID)B	f=1kHz Tone mid setting +8dB	6	8	10	dB
Value of Cut(Mid)	G(MID)B	f=1kHz Tone mid setting -8dB	-10	-8	-6	dB
Value of Boost(Treble)	G(TRE)B	f=10kHz Tone treble setting +8dB	6	8	10	dB
Value of Cut(Treble)	G(TRE)B	f=10kHz Tone treble setting -8dB	-10	-8	-6	dB
Balance between channels	BALT	boost condition +8,-8dB	-2	0	+2	dB

**PRELIMINARY**  
 Notice ; This is not a final specification.  
 some parametric limits are subject to change.

# M61504FP

## DIGITAL SOUND CONTROLLER WITH SURROUND

### FUNCTION DESCRIPTION

#### (1) Main volume

This IC has 2 system independence electron volume of low warp percentage and low noise.  
 0dB ~ - dB attenuation quantity can be set with 36 steps (0dB ~ -44dB: 2dB step, -44dB ~ -76dB: 4dB step, -77dB ~ -80dB: 1dB step).

The attenuation quantity to 0 ~ -16dB can be set in A1 Vol.

The attenuation quantity to 0 ~ -64dB can be set in B1 Vol. They are possible to control.

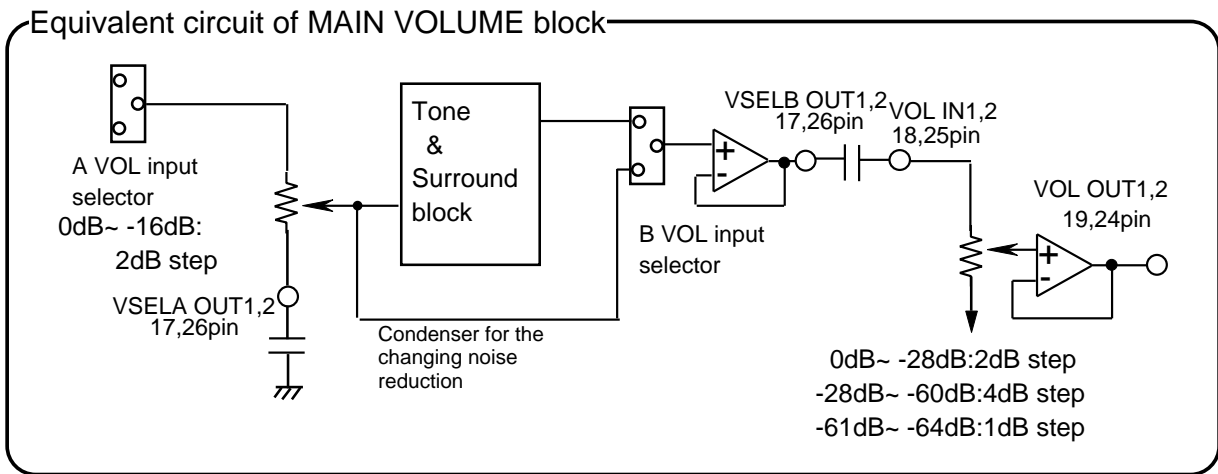

#### (2) Input selector, Input volume

This IC has 4 input selector of 2ch and Input volume of 2ch for Input TRIMMER.  
 The input selector D input is either of -8 dB or 0dB/ a choice in the input level with ATT SW.  
 The input volume of 0 ~ -14dB can be set with the 2 dB step.

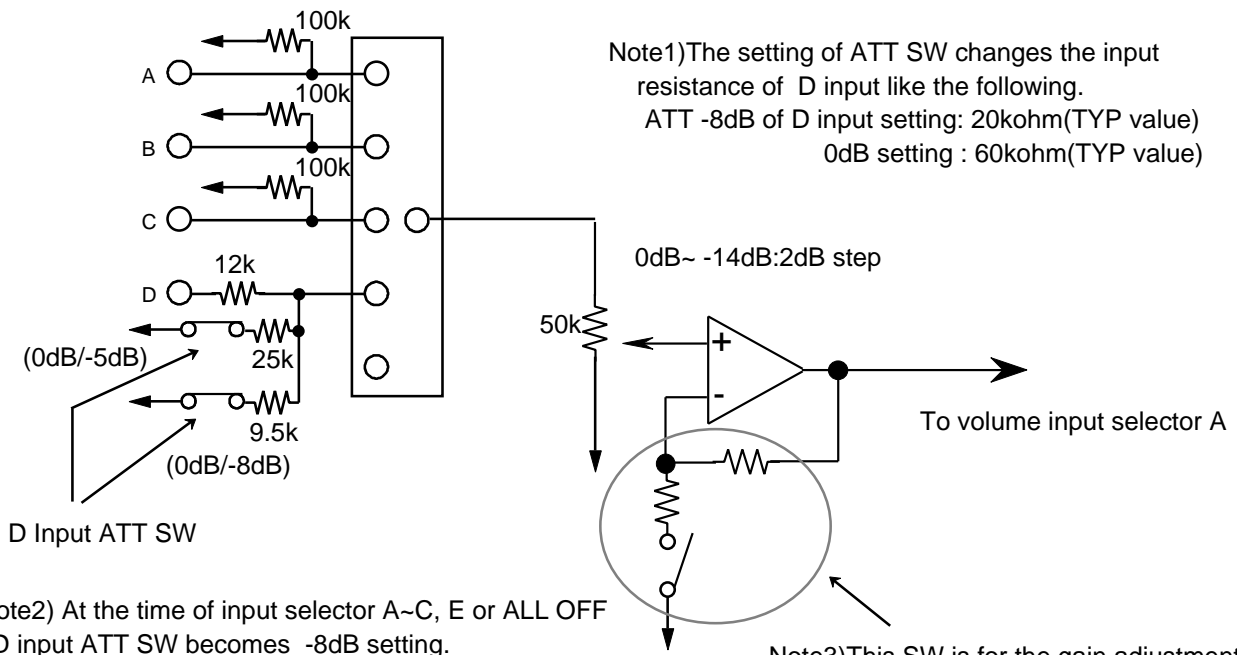

**PRELIMINARY**  
 Notice ; This is not a final specification.  
 some parametric limits are subject to change.

MITSUBISHI SOUND PROCESSORS

# M61504FP

## DIGITAL SOUND CONTROLLER WITH SURROUND

### (3)Equivalent circuit of tone control 3-1 Bass, Mid (Boost mode)

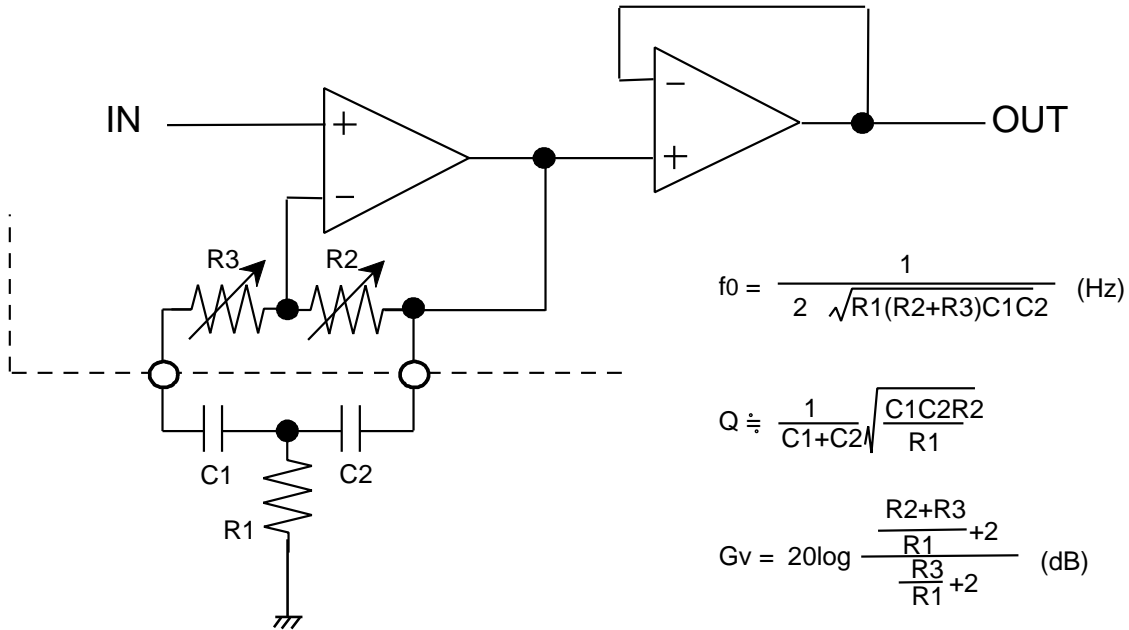

### 3-2 Bass, Mid (Cut mode)

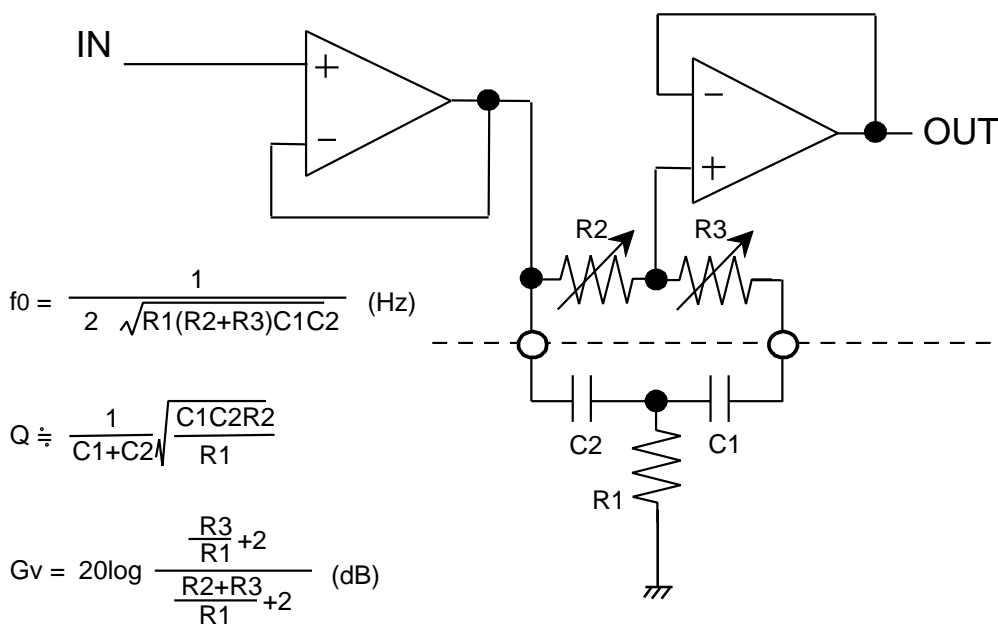

**PRELIMINARY**  
 Notice ; This is not a final specification.  
 some parametric limits are subject to change.

MITSUBISHI SOUND PROCESSORS

# M61504FP

## DIGITAL SOUND CONTROLLER WITH SURROUND

### 3-3 Treble (Boost)

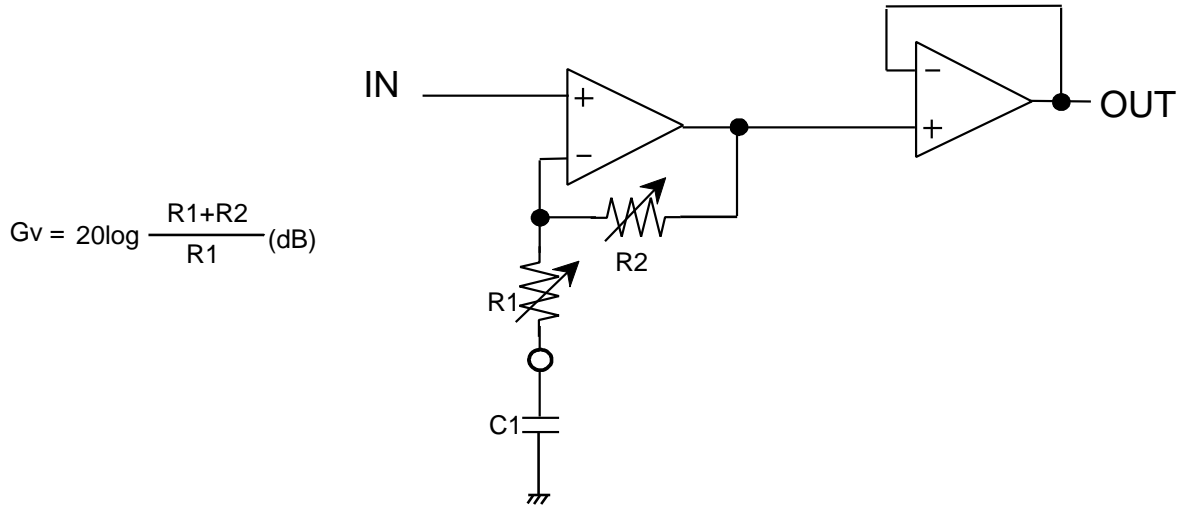

### 3-4 Treble (Cut)

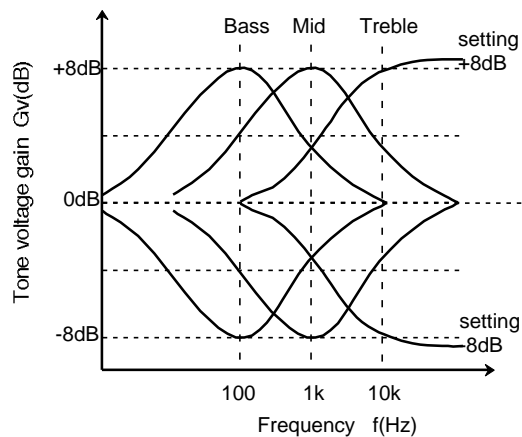
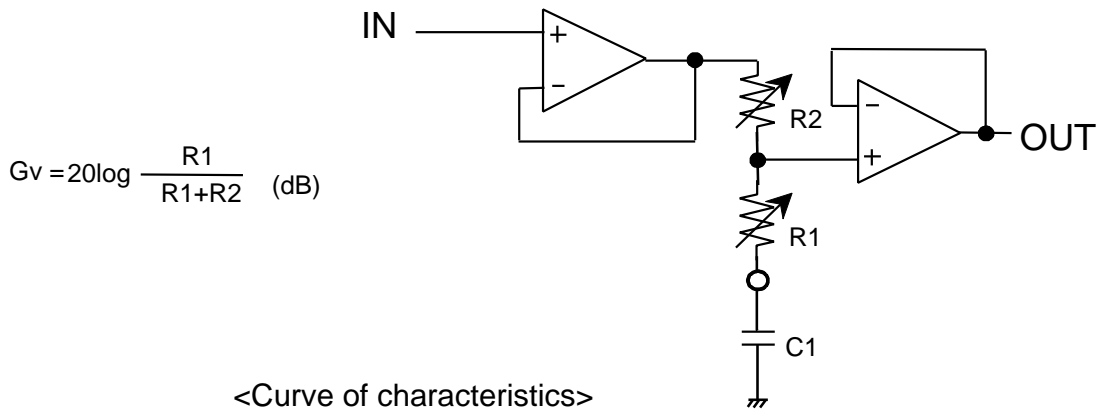

**PRELIMINARY**  
 Notice ; This is not a final specification.  
 some parametric limits are subject to change.

MITSUBISHI SOUND PROCESSORS

# M61504FP

## DIGITAL SOUND CONTROLLER WITH SURROUND

### (4) Equivalent circuit of Vocal cut

It removes the vocal cut from usual music source (the stereo).

It centers on the vocal cut by the fixed rank, it is inputted to L,Rch in the same phase and the same amplitude. Therefore, it comes in the vocal cut by L-R setting.

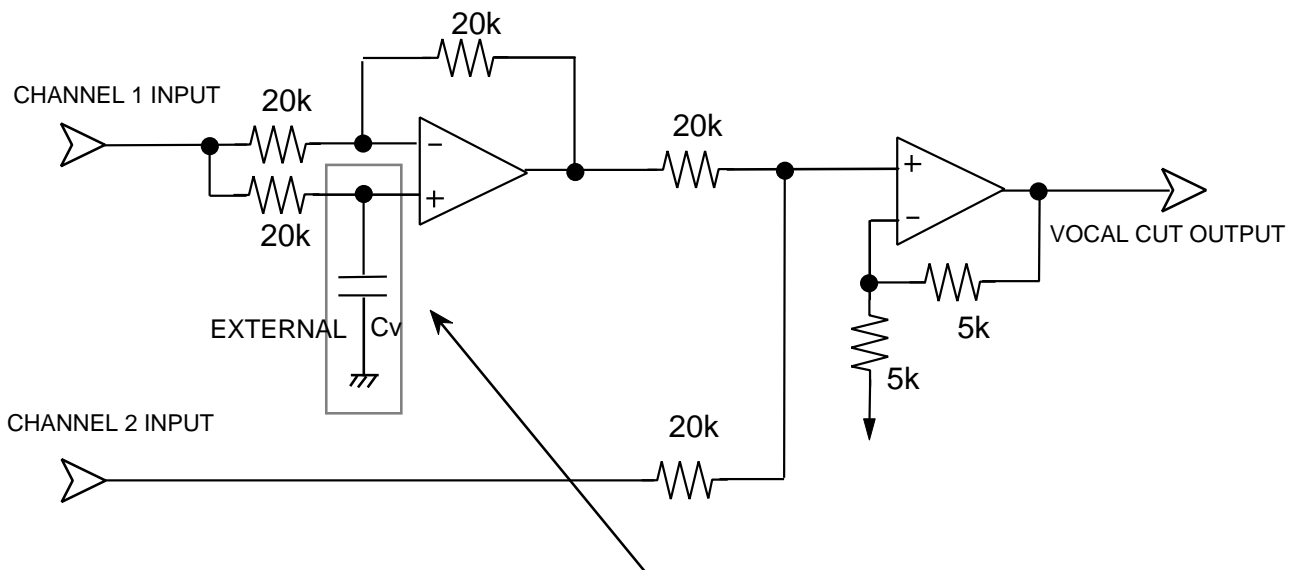

Lowpass filter for Vocal cut

Note1) Vocal cut output is monaural.

Note2) In the setting which uses the vocal cut, the inside surround function can't be used.

Note3) In setting of the vocal cut use, the output sometimes does a clip in the low area part, when inputting a signal above  $V_{in}=0.6V_{rms}$ .

### <CHARACTERISTIC CURVE>

It fixes ( $f_o$ ) of the low cut off frequency in 20K of the inside resistance and Cv of the outside capacitor. It shows by the formula below.

$$f_o = 1 / (2 \times 20k \times C) \text{ Hz}$$

$$C = 0.68\mu\text{F} \text{ setting}$$

It becomes

$$f_o = 1 / (2 \times 20k \times 0.68\mu) = 12\text{Hz}$$

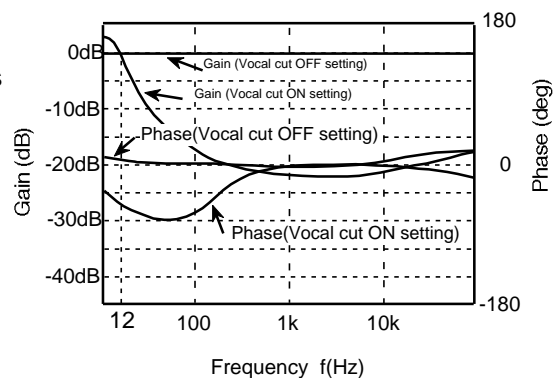

**PRELIMINARY**  
 Notice ; This is not a final specification.  
 some parametric limits are subject to change.

# M61504FP

## DIGITAL SOUND CONTROLLER WITH SURROUND

### (5) LOUDNESS

This IC built-in a center tap -type loudness circuit .

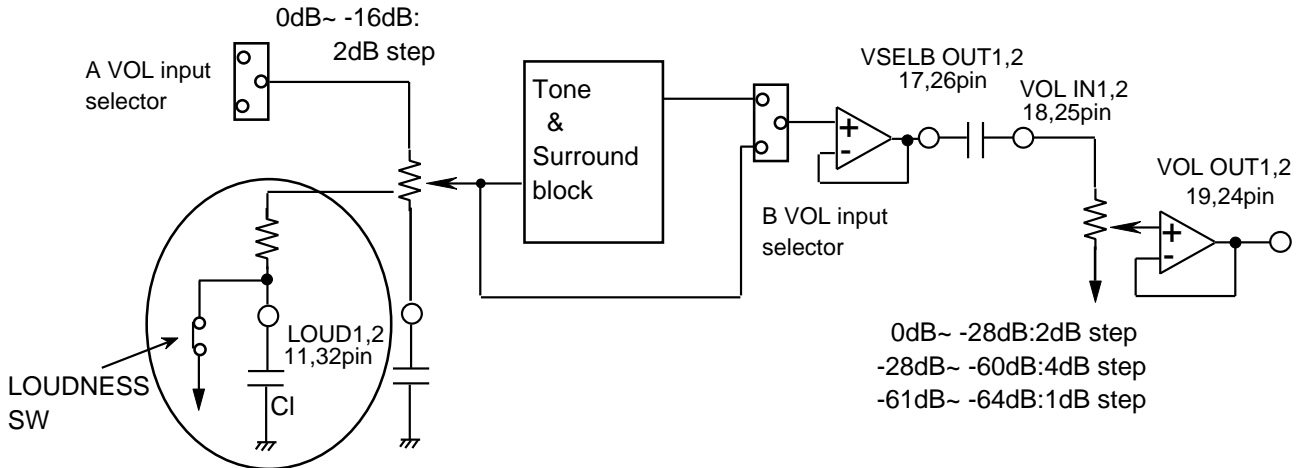

0dB ~ -28dB: 2dB step  
 -28dB ~ -60dB: 4dB step  
 -61dB ~ -64dB: 1dB step

LOUDNESS PART

It fixes (fo) of the loudness in 50K of the inside resistance and C1 of the outside capacitor. It shows by the formula below.

$$f_o = 1 / (2 \times 50k \times C) \text{ Hz}$$

C = 0.1μF setting

It becomes

$$f_o = 1 / (2 \times 50k \times 0.1\mu) = 32\text{Hz}$$

### (6) Equivalent circuit of surround block

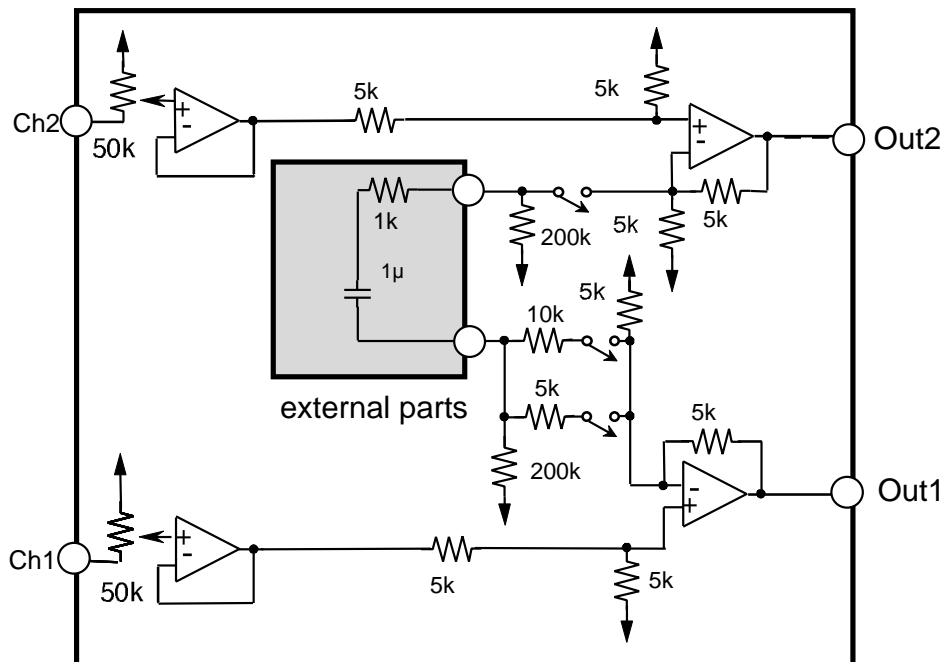
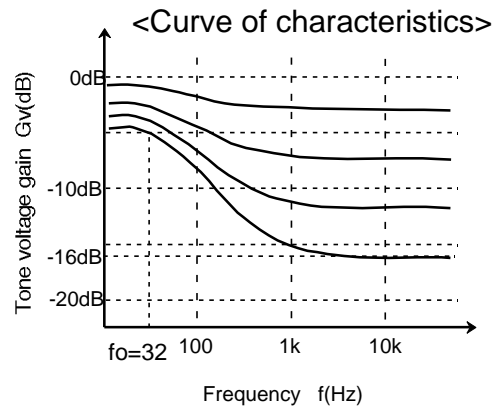

**PRELIMINARY**  
 Notice ; This is not a final specification.  
 some parametric limits are subject to change.

MITSUBISHI SOUND PROCESSORS

# M61504FP

## DIGITAL SOUND CONTROLLER WITH SURROUND

### APPLICATION EXAMPLE

(1) Surround of outside setting (for Dolby-Pro-logic)

<"D54=1"--->SW41, 42 setting = B fixation.>

But, in case of this specification inside surround can not be used.

Units Resistance:  
 Capacitance:F

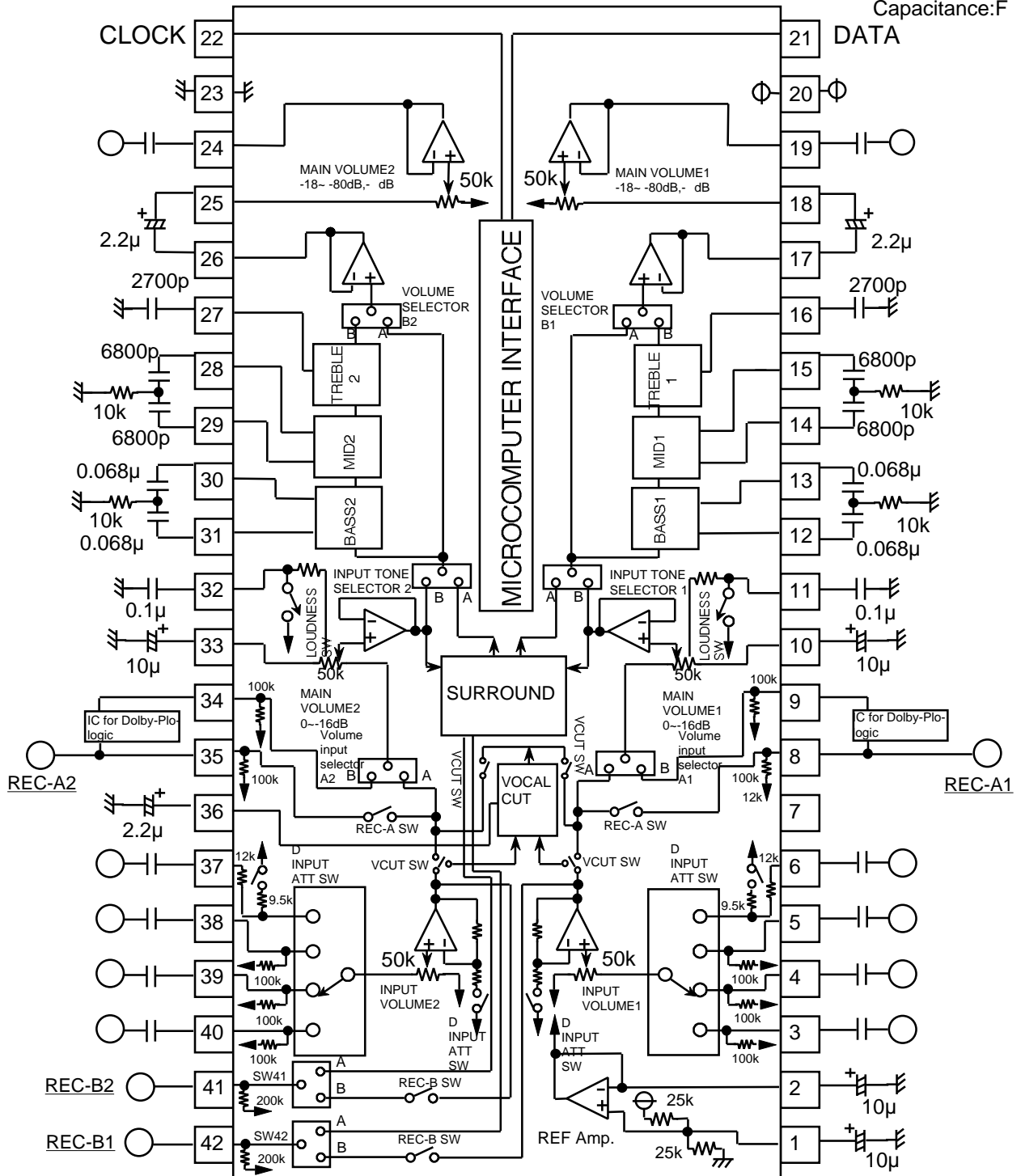

**PRELIMINARY**  
 Notice ; This is not a final specification.  
 some parametric limits are subject to change.

MITSUBISHI SOUND PROCESSORS

# M61504FP

## DIGITAL SOUND CONTROLLER WITH SURROUND

(2) Surround of outside setting (for Dolby-Pro-logic)

<"D54=0"---> SW41, 42 setting = A fixation>

Units Resistance:  
 Capacitance:F

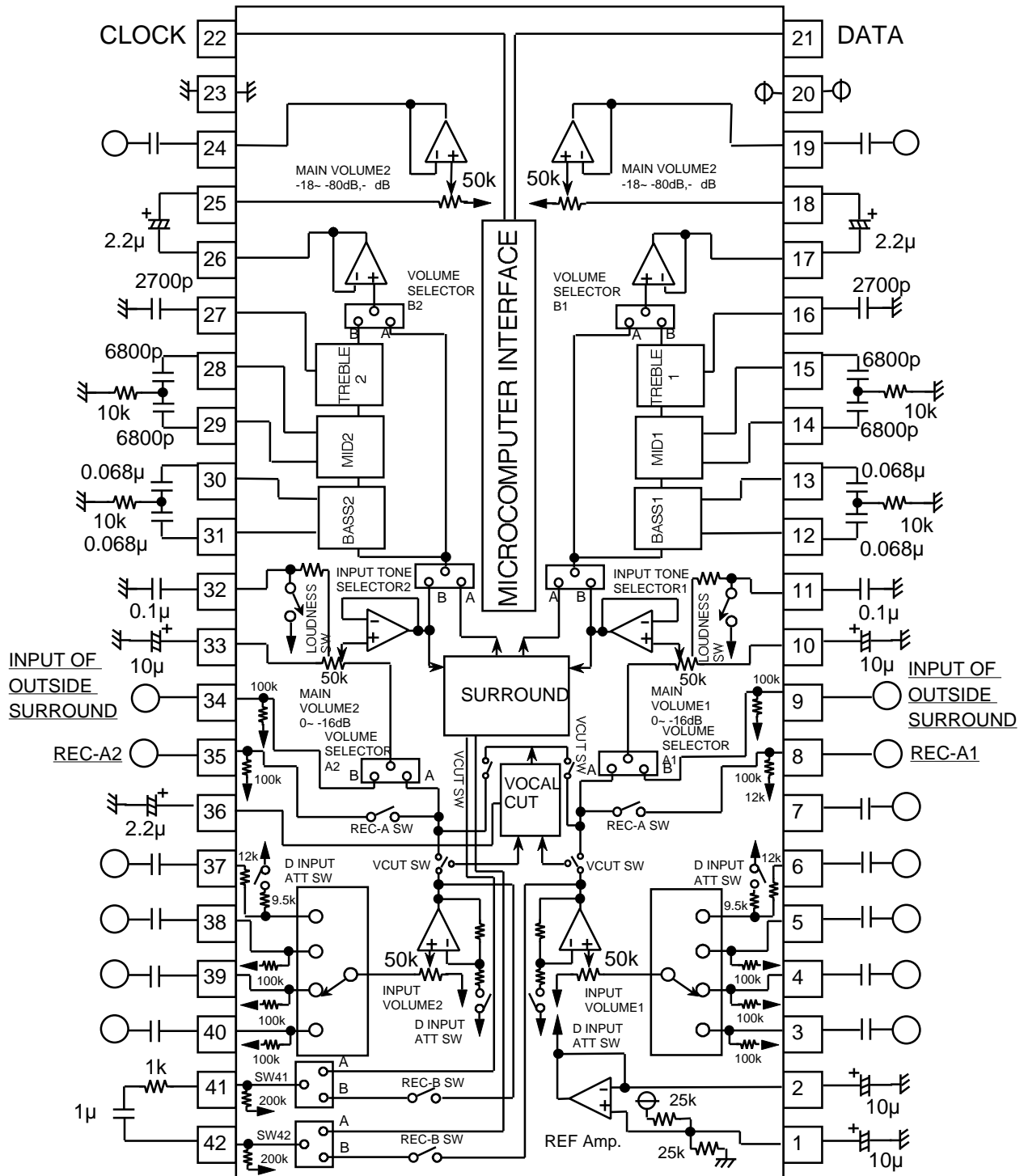

This datasheet has been download from:

[www.datasheetcatalog.com](http://www.datasheetcatalog.com)

Datasheets for electronics components.