

# Sensorless Smart-Start™ BLDC PWM Motor Controller

## GENERAL DESCRIPTION

The ML4428 motor controller provides all of the functions necessary for starting and controlling the speed of delta or wye-wound Brushless DC (BLDC) Motors without the need for Hall Effect sensors.

Back-EMF voltage is sensed from the motor windings to determine the proper commutation phase sequence using PLL techniques. The patented back-EMF sensing technique used will commutate virtually any 3-phase BLDC motor that has at least a 30% variation in inductance during rotation and is insensitive to PWM noise and motor snubbing circuitry.

The ML4428 also utilizes a patented start-up technique which samples the rotor position and applies the proper drive to accelerate the motor. This ensures no reverse rotation at start-up and reduces total start-up time.

## FEATURES

- Stand-alone operation with forward and reverse
- On-board start sequence: Sense Position ∅ Drive ∅ Accelerate ∅ Set Speed
- No backward movement at start-up
- Patented back-EMF commutation technique
- Simple variable speed control with on-board reference
- Single external resistor sets all critical currents
- PWM control for maximum efficiency or linear control for minimum noise
- 12V operation provides direct FET drive for 12V motors
- Drives high voltage motors with high side FET drivers
- Guaranteed no shoot-through when driving external FET gates directly

\* Some Packages Are End Of Life

## BLOCK DIAGRAM/TYPICAL APPLICATION

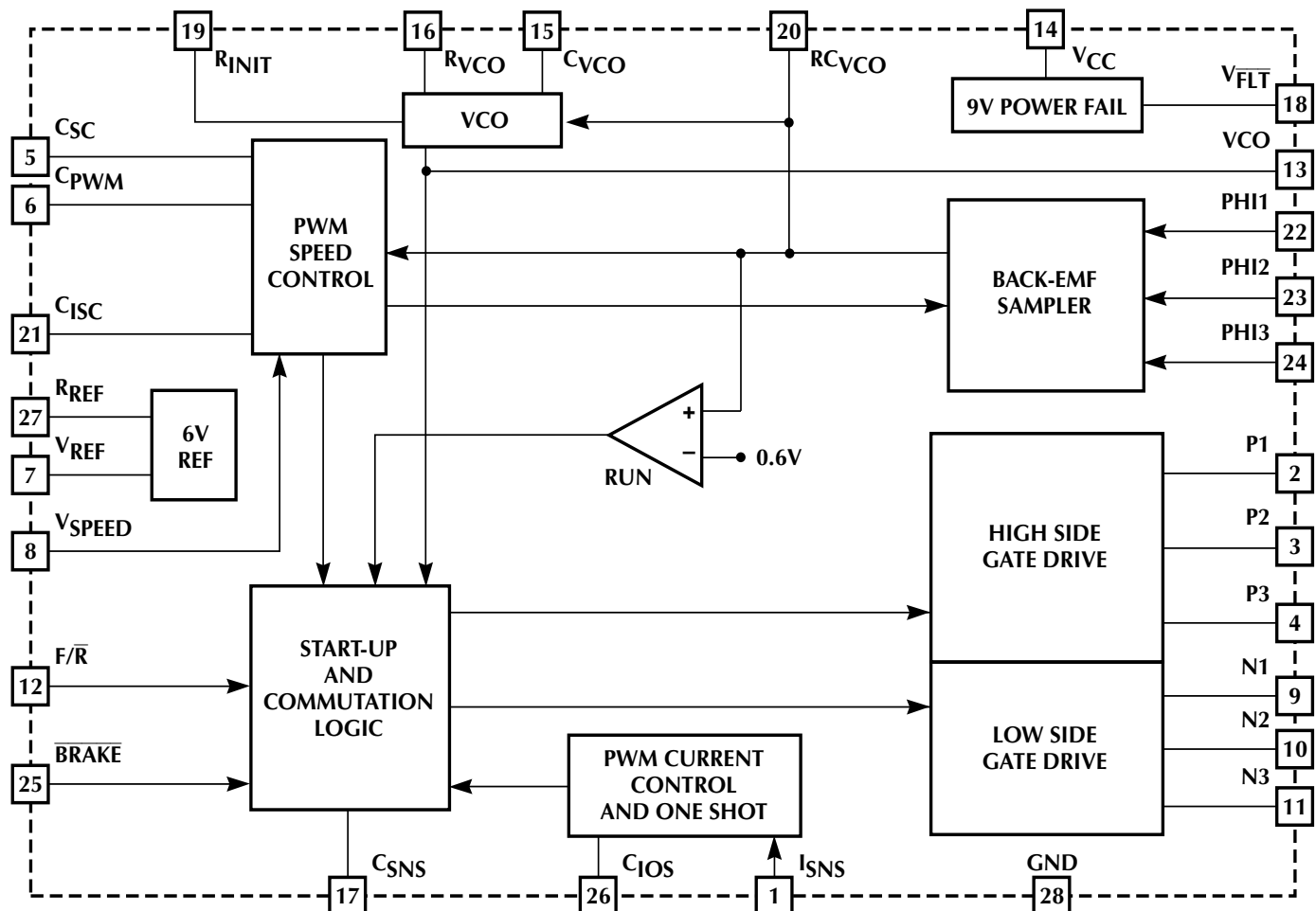

## PIN CONFIGURATION

ML4428  
 28-Pin Molded Narrow Dip (P28N)  
 28-Pin SOIC(S28)

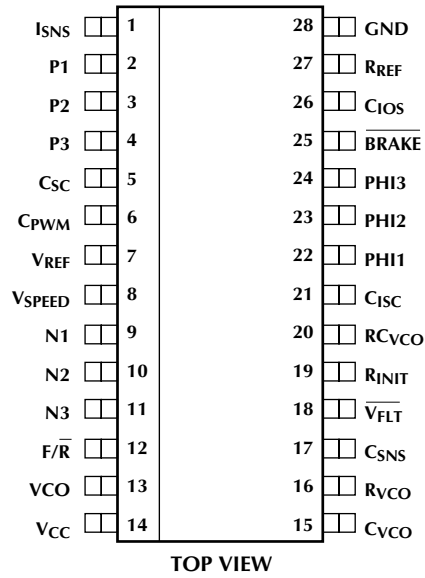

## PIN DESCRIPTION

PIN	NAME	FUNCTION	PIN	NAME	FUNCTION
1	I <sub>SNS</sub>	Motor current sense input. Current limit one-shot is triggered when this pin is approximately 0.5V.	16	R <sub>VCO</sub>	The resistor on this pin sets a process independent current to generate a repeatable VCO frequency.
2	P1	Drives the external P-channel transistor driving motor PHI1.	17	C <sub>SNS</sub>	This capacitor to ground sets the ON time of the 6 sense pulses used for position detection at start-up and at low speeds. A 5.6nF capacitor will set the on time to approximately 200µs.
3	P2	Drives the external P-channel transistor driving motor PHI2.	18	$\overline{V}_{FLT}$	A logic "0" indicates the power supply is under-voltage. (TTL level)
4	P3	Drives the external P-channel transistor driving motor PHI3.	19	R <sub>INIT</sub>	This resistor sets the minimum VCO frequency, and thus, the initial on time of the drive energization at start-up. A 2 MΩ resistor to ground sets the minimum VCO frequency to approximately 10Hz, resulting in an initial drive energization pulse of 100ms in conjunction with 82nF C <sub>VCO</sub> and 10k R <sub>VCO</sub> .
5	C <sub>SC</sub>	The resistor/capacitor combination on this gm amplifier output sets a pole zero of the speed loop in conjunction with a gm of 0.230mmho.	20	R <sub>C<sub>VCO</sub></sub>	VCO loop filter components.
6	C <sub>PWM</sub>	A capacitor to ground at this pin sets the PWM oscillator frequency. A 1nF capacitor will set the frequency to approximately 25kHz for PWM speed control. Grounding this pin selects linear speed control.	21	C <sub>ISC</sub>	A capacitor to ground at this gm amplifier output sets a pole in the current-mode portion of the speed loop in conjunction with a gm of 0.230mmho.
7	V <sub>REF</sub>	This voltage reference output (6V) can be used to set the speed reference voltage.	22	PHI1	Motor Terminal 1
8	V <sub>SPEED</sub>	This voltage input to the amplifier in the speed loop controls the speed target of the motor.	23	PHI2	Motor Terminal 2
9	N1	Drives the external N-channel MOSFETs for PHI1.	24	PHI3	Motor Terminal 3
10	N2	Drives the external N-channel MOSFETs for PHI2.	25	$\overline{BRAKE}$	A "0" activates the braking circuit. (TTL level)
11	N3	Drives the external N-channel MOSFETs for PHI3.	26	C <sub>IOS</sub>	A 50µA current from this pin will charge a timing capacitor to GND for fixed OFF-time PWM current control
12	F/ $\overline{R}$	The forward/reverse pin controls the sequence of the commutation states and thus the direction of motor rotation. (TTL level)	27	R <sub>REF</sub>	This resistor sets constant currents on the device to reduce process dependence and external components. A 120k resistor sets the previously mentioned current levels.
13	VCO	This logic output indicates the commutation frequency of the motor in run mode. (TTL level)	28	GND	Signal and Power Ground
14	V <sub>CC</sub>	12V power supply.			
15	C <sub>VCO</sub>	Timing capacitor for VCO			

## ABSOLUTE MAXIMUM RATINGS

Absolute maximum ratings are those values beyond which the device could be permanently damaged. Absolute maximum ratings are stress ratings only and functional device operation is not implied.

Supply Voltage (pin 14) .....	14V
Output Current (pins 2, 3, 4, 9,10,11) .....	±50mA
Logic Inputs (pins 12, 25) .....	-0.3 to 7V
Junction Temperature .....	150°C
Storage Temperature Range .....	-65°C to 150°C
Lead Temperature (Soldering 10 sec.) .....	260°C
Thermal Resistance ( $\theta_{JA}$ )	
Plastic DIP .....	52°C/W
Plastic SOIC .....	75°C/W

## OPERATING CONDITIONS

Temperature Range

    Commercial ..... 0°C to 70°C

    Industrial ..... -40°C to 85°C

V<sub>CC</sub> Voltage ..... 12V ±10%

## ELECTRICAL CHARACTERISTICS

Unless otherwise specified, T<sub>A</sub> = 0°C to 70°C, V<sub>CC</sub> = 12V, R<sub>SNS</sub> = 0.3 $\Omega$ , C<sub>VCO</sub> = 82nF, C<sub>IOS</sub> = 100pF, R<sub>REF</sub> = 120k $\Omega$ , C<sub>SNS</sub> = 5.6nF, R<sub>VCO</sub> = 10k, R<sub>INIT</sub> = 2Meg (Notes 1, 2, and 3)

SYMBOL	PARAMETER	CONDITIONS	MIN	TYP	MAX	UNITS	
Oscillator (VCO)							
	Frequency vs. V <sub>PIN 20</sub>	R <sub>VCO</sub> = 2V	0°C to 70°C	550	600	750	Hz/V
			-40°C to 85°C	520	600	750	Hz/V
	Maximum Frequency	R <sub>VCO</sub> = 6V	0°C to 70°C	1850	2150	2350	Hz
			-40°C to 85°C	1650	2150	2350	Hz
Sampling Amplifier							
	I <sub>RCVCO</sub> (Note 4)	State A, V <sub>PH2</sub> = V <sub>CC</sub> /3	80	116	150	$\mu$ A	
		State A, V <sub>PH2</sub> = V <sub>CC</sub> /2	-25	0	25	$\mu$ A	
		State A, V <sub>PH2</sub> = 2V <sub>CC</sub> /3	-150	-116	-80	$\mu$ A	
Current Limit							
	I <sub>SNS</sub> Trip Point		0.45	0.5	0.55		
	One Shot Off Time		10	13	15	$\mu$ s	
Power Fail Detection							
	Power Fail Trip Voltage		8.0		9.0	V	
	Hysteresis		300	500	700	mV	
Logic Inputs							
V <sub>IH</sub>	Voltage High		2			V	
V <sub>IL</sub>	Voltage Low				0.8	V	
I <sub>IH</sub>	Current High	V <sub>IN</sub> = 2.7V	-300		0	$\mu$ A	
I <sub>IL</sub>	Current Low	V <sub>IN</sub> = 0.4V	-400		0	$\mu$ A	
Logic Outputs							
V <sub>OH</sub>	Voltage High	I <sub>OUT</sub> = -0.1mA		3.3		V	
V <sub>OL</sub>	Voltage Low	I <sub>OUT</sub> = 1mA		0.4		V	

## ELECTRICAL CHARACTERISTICS (Continued)

SYMBOL	PARAMETER	CONDITIONS	MIN	TYP	MAX	UNITS	
Output Drivers							
	V <sub>P</sub> High	I <sub>P</sub> = -10μA	V <sub>CC</sub> - 1.2			V	
	V <sub>P</sub> Low			0.7	1.2	V	
	I <sub>P</sub> Low	V <sub>P</sub> = 1V	0°C to 70°C	2.5	4	6	mA
			-40°C to 85°C	1.5	4	6	mA
	P Comparator Threshold		V <sub>CC</sub> - 3.0			V	
	V <sub>N</sub> High	V <sub>PIN12</sub> = 0V	V <sub>CC</sub> - 1.2			V	
	V <sub>N</sub> Low	I <sub>N</sub> = 1mA		0.7	1.2	V	
	N Comparator Threshold				3	V	
Speed Control							
	f <sub>PWM</sub>	C <sub>OSC</sub> = 1nF	20	25	36	kHz	
	gm Current			±160		μA	
	CSC Positive Clamp		2.9	3.1	3.35	V	
	CISC Positive Clamp		5.2	5.5	5.6	V	
	CISC Negative Clamp		1.2	1.7	1.9	V	
	V <sub>REF</sub>		5.5	5.9	6.5	V	
Supply							
	V <sub>CC</sub> Current		18	25	32	mA	

**Note 1:** Limits are guaranteed by 100% testing, sampling or correlation with worst case test conditions.

**Note 2:** F/R and BRAKE have internal 17kΩ pull-up resistors to an internal 5V reference.

**Note 3:** V<sub>FLT</sub> and VCO have internal 4.3kΩ pull-up resistors to an internal 5V reference.

**Note 4:** For explanation of states, see Figure 6 and Table 1.

## FUNCTIONAL DESCRIPTION

The ML4428 provides closed-loop commutation for 3-phase brushless motors. To accomplish this task, a VCO, integrating back-EMF Sampling error amplifier and sequencer form a phase-locked loop, locking the VCO to the back-EMF of the motor. The IC contains circuitry to control motor speed in PWM mode. Braking and power fail detection functions are also provided on the chip. The ML4428 is designed to drive external power transistors (N-channel sinking transistors and P-channel sourcing transistors) directly.

The ML4428 limits the motor current with a constant off-time PWM controlled current. The velocity loop is controlled with an on-board amplifier. An accurate, jitter-free VCO output is provided equal to the commutation frequency of the motor. The ML4428 switches the gates of external N-channel power MOSFETs to regulate the motor current and directly drives the P-channel MOSFETs for 12V motors. The ML4428 ensures that there is no shoot through in any state of power drive to the FETs. Higher voltage motors can be driven using buffer transistors or standard "high side" drivers.

Speed sensing is accomplished by monitoring the output of the VCO, which will be a signal which is phase-locked to the commutation frequency of the motor.

### BACK-EMF SENSING AND COMMUTATOR

The ML4428 contains a patented back-EMF sensing circuit (Figure 1) which samples the phase which is not energized (Shaded area in Figure 2) to determine whether to increase or decrease the commutator (VCO) frequency. A late commutation causes the error amplifier to charge the filter

(RC) on  $R_{CVCO}$ , increasing the VCO input while early commutation causes  $R_{CVCO}$  to discharge. The analog speed control loop uses  $R_{CVCO}$  as a speed feedback voltage.

The input impedance of the three PH inputs is about  $8.7k\Omega$  to GND. When operating with a higher voltage motor, the PH inputs should be divided down in voltage with series resistors so that the maximum voltage at any PH input does not exceed  $V_{CC}$ .

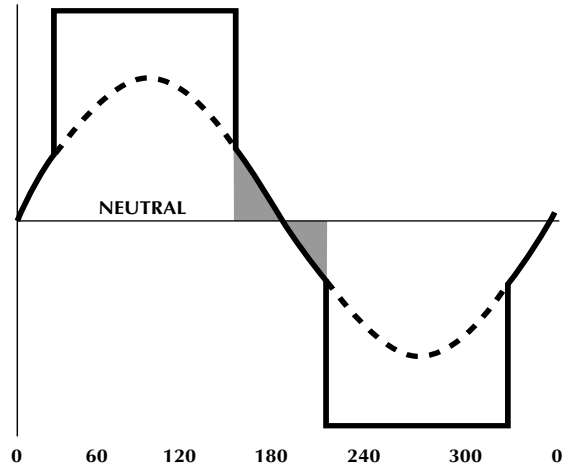

Figure 2. Typical Motor Phase Waveform with back-EMF Superimposed (Ideal Commutation).

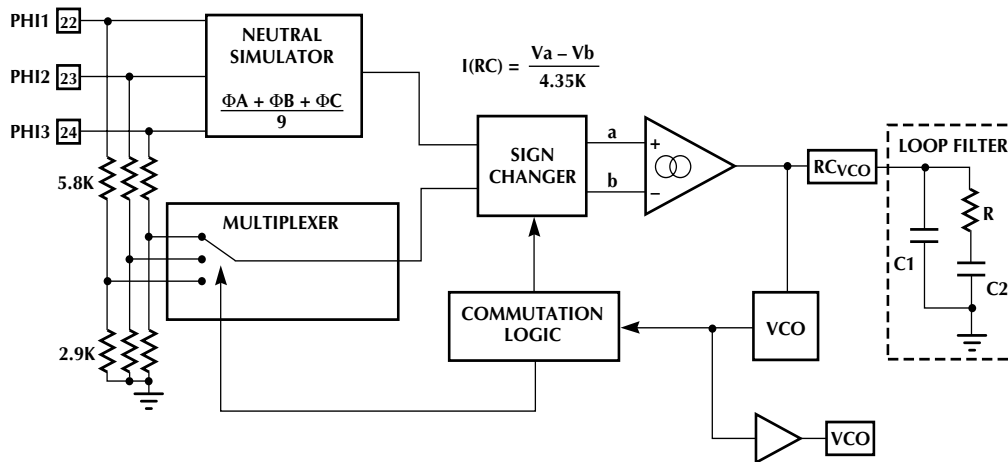

Figure 1. Back-EMF Sensing Block Diagram

## COMPONENT SELECTION GUIDE

In order to properly select the critical components for the ML4428 you should know the following things:

1. The motor operating voltage,  $V_{MOTOR}$  (V).
2. The maximum operating current for the motor,  $I_{MAX}$  (A).
3. The number of poles the motor has,  $N$ .
4. The back-EMF constant of the motor,  $K_e$  ( $V \propto s/rad$ ).
5. The torque constant of the motor,  $K_t$  ( $N \propto m/A$ ). (This is the same as the back-EMF constant, only in different units.)
6. The maximum desired speed of operation,  $RPM_{MAX}$  (rpm).
7. Line to line resistance,  $R_{L-L}$  (Ohms).
8. Line to line inductance,  $L_{L-L}$  (Henries).
9. The motor should have at least 15% line-to-line inductance variation during rotation for proper start-up sensing. (Air core motors will not run using the ML4428.) Examine the motor to determine if there is any iron in the core. If the stator coils are not wound around an iron form, the ML4425 or ML4426 may be a better choice.

If you do not know one or more of the above values, it is still possible to pick components for the ML4428, but some experimentation may be necessary to determine the optimal value. All quantities are in SI units unless otherwise specified. The formulas in the following section are based on linear system models. The following formulas should be considered a starting point from which you can optimize your application.

Note: Refer to Application Note 43 for details on loop compensation.

 $R_{SENSE}$ 

The function of  $R_{SENSE}$  is to provide a voltage proportional to the motor current, for current limit/feedback purposes. The trip voltage across  $R_{SENSE}$  is 0.5V so:

$$R_{SENSE} = \frac{0.5}{I_{MAX}}$$

$I_{MAX}$  is the maximum motor current.

The power dissipation in the resistor is  $I_{MAX}$  squared times  $R_{SENSE}$ , so the resistor should be sized appropriately. For very high current motors, a smaller resistor can be used, with an op-amp to increase the gain, so that power dissipation in the sense resistor is minimized.

## RES1, RES2 and RES3

Operating motors at greater than 12V requires attenuation resistors in series with the sense inputs (PHI1, PHI2, PHI3) to keep the voltage less than 12V. The phase sense input impedance is 8700 $\Omega$ . This requires the external resistor to be set as follows and results in the given attenuation.

$$RES1 = RES2 = RES3$$

$$RES1 = 725 (V_{MOTOR} - 10)$$

$$Atten = \frac{2900}{RES1 + 8700}$$

A larger value for RES1 may be required if the peak motor phase voltage exceeds  $V_{MOTOR}$ .

 $I_{SENSE}$  FILTER

The  $I_{SENSE}$  filter consists of an RC lowpass filter in series with the current sense signal. The purpose of this filter is to filter out noise spikes on the current, which may cause false triggering of the one shot circuit. It is important that this filter not slow down the current feedback loop, or destruction of the output stage may result. The recommended values for this circuit are  $R = 1K\Omega$  and  $C = 300pF$ . This gives a time constant of 300ns, and will filter out spikes of shorter duration. These values should suffice for most applications. If excessive noise is present on the  $I_{SENSE}$  pin, the capacitor may be increased at the expense of speed of current loop response. The filter time constant should not exceed 500ns or it will have a significant impact on the response speed of the one shot current limit.

 $C_{IOS}$ 

The one shot capacitor determines the off time after the current limit is activated, i.e. the voltage on the  $I_{SENSE}$  pin exceeded 0.5V. The following formula ensures that the motor current is stable in current limit:

$$C_{IOS(MAX)} = 1.11 \times 10^{-11} \times V_{MOTOR}$$

$C_{IOS}$  is in Farads

This is the maximum value that  $C_{IOS}$  should be. Higher average torque during the current limit cycle can be achieved by reducing this value experimentally, while monitoring the motor current carefully, to be sure that a runaway condition does not occur. This runaway condition occurs when the current gained during the on time exceeds the current lost during the off time, causing the motor current to increase until damage occurs. For most motors this will not occur, as it is usually a self limiting phenomenon. (See Figure 7)

## $C_{VCO}$

As given in the section on the VCO and phase detector:

$$C_{VCO} = \frac{2931 \times 10^{-6}}{N \times RPM_{MAX}}$$

Where N is the number of poles in the motor, and RPM is the motor's maximum operating speed in revolutions per minute.

## $C_{PWM}$

This capacitor sets the PWM ramp oscillator frequency. This is the PWM "switching frequency". If this value is too low, <20kHz, then magnetostriction effects in the motor may cause audible noise. If this frequency is too high, >30kHz, then the switching losses in the output drivers may become a problem. 25kHz should be a good compromise for this value, which can be obtained by using a 1nF capacitor.

## $R_{VCO}$ AND $R_{REF}$

$R_{VCO}$  should be 10k and  $R_{REF}$  should be 120k for normal operation.

## VCO FILTER

See the section on the VCO and Phase detector for information on these components.

## VCO AND PHASE DETECTOR CALCULATIONS

The VCO should be set so that at the maximum frequency of operation (the running speed of the motor) the VCO control voltage will be no higher than  $V_{REF}$ , or 6V. The VCO maximum frequency will be:

$$F_{MAX} = 0.05 \times N \times RPM_{MAX}$$

where N is the number of poles on the motor and  $RPM_{MAX}$  is the maximum motor speed in Revolutions Per Minute.

The minimum VCO gain derived from the specification table (using the minimum  $F_{VCO}$  at  $V_{VCO} = 6V$ ) is:

$$K_{VCO(MIN)} = \frac{2.665 \times 10^{-5}}{C_{VCO}}$$

Assuming that the  $V_{VCO(MAX)} = 5.5V$ , then

$$C_{VCO} = \frac{5.5 \times 2.665 \times 10^{-5}}{F_{MAX}}$$

or

$$C_{VCO} = \frac{2931 \times 10^{-6}}{N \times RPM_{MAX}}$$

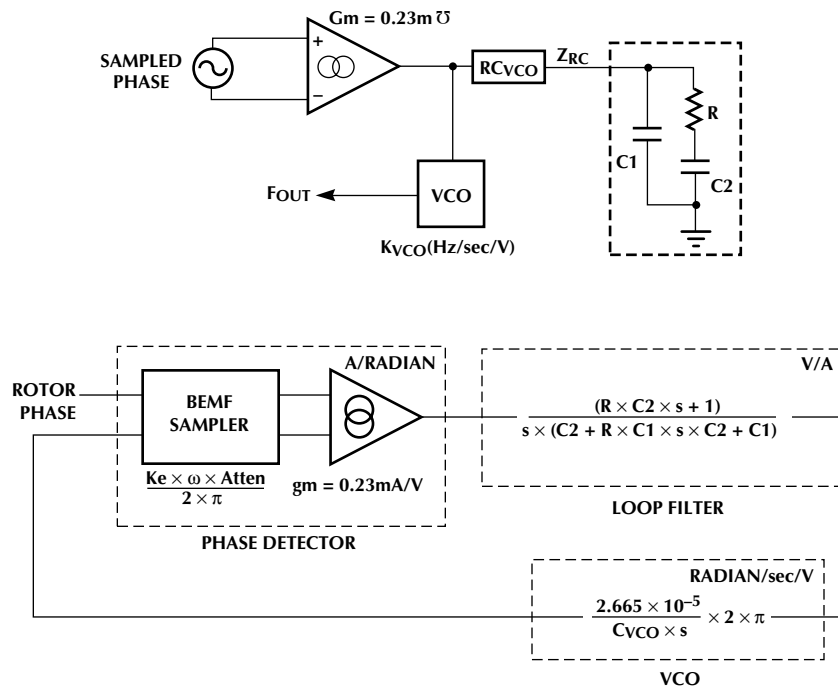

Figure 4. Back-EMF Phase Locked Loop Components.

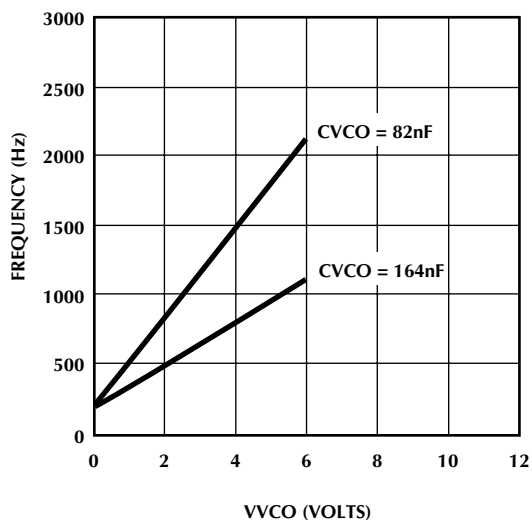

Figure 3. VCO Output Frequency vs.  $V_{VCO}$  (Pin 20)

Figure 4 shows the linearized transfer function of the Phase Locked Loop with the phase detector formed from the sampled phase through the Gm amplifier with the loop filtered formed by R,  $C_1$ , and  $C_2$ . The Phase detector gain is:

$$\frac{K_e \times \omega \times \text{Atten}}{2\pi} \times 2.3 \times 10^{-4} \text{ A/Radian}$$

Where  $K_e$  is the motor back-E.M.F. constant in V/Radian/sec,  $\omega$  is the rotor speed in r/s, and Atten is the back-E.M.F. resistive attenuator, nominally 0.3.

The simplified impedance of the loop filter is

$$Z_{RC}(s) = \frac{1}{C_1 s} \frac{(s + \omega_{LEAD})}{(s + \omega_{LAG})}$$

Where the lead and lag frequencies are set by:

$$\omega_{LEAD} = \frac{1}{RC_2}$$

$$\omega_{LAG} = \frac{C_1 + C_2}{RC_1 C_2}$$

Requiring the loop to settle in 20 PLL cycles with  $\omega_{LAG} = 10 \times \omega_{LEAD}$  produces the following calculations for R,  $C_1$  and  $C_2$ :

$$C_1 = \frac{7.508 \times 10^{-4} \times \text{Atten} \times K_e}{N}$$

$$C_2 = 9 \times C_1$$

$$R = \frac{8.89 \times 10^4}{\text{Atten} \times K_e \times \text{RPM}_{MAX}}$$

where  $K_e$  is the back-EMF constant in volts per radian per second, and  $\text{RPM}_{MAX}$  is the rotor speed. See Micro Linear application note 35 for derivation of the above formulas.

The 80k resistor to GND from the  $RC_{VCO}$  pin assists in a smooth transition from sense mode to closed loop operation.

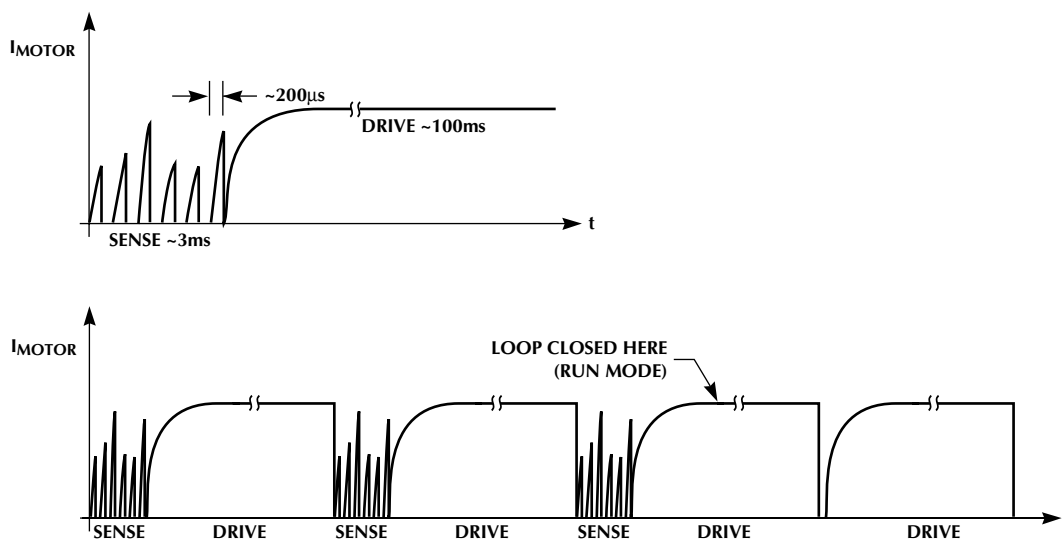

Figure 5. Typical Sensed Start-up

## C<sub>SNS</sub>

A capacitor to ground at this pin sets the ON time of the 6 current sense pulses used for position detection at start-up and at low speeds. The ON time is set by:

$$T_{ON} = C_{SNS} (35.7k)$$

Referring to Figure 5, each of the 6 current sense pulses is governed by a rise time with a time constant of L/R where L is the inductance of the motor network with 2 windings shorted and R is the total resistance in series with the motor between the supply rails. R includes the ON-resistance of the power-FETs and R<sub>SNS</sub>. The R<sub>DSON</sub> of the high side FET should match that of the low side FET. L is a function of rotor position. Each pulse will have a peak value V<sub>SENSEPEAK</sub> of

$$V_{SENSEPEAK} = R_{SNS} \frac{V_{MOTOR}}{R} \left( 1 - e^{-\frac{T_{ON}}{L/R}} \right)$$

where

$$R = 0.75 \times (R_{L-L} + 2 \times R_{SDON}) + R_{SENSE}$$

$$L = 0.75 \times L_{L-L}$$

What is important for sensing rotor position is the amplitude difference between each of the three pairs of current sense pulses. This can be seen by triggering on I<sub>SNS</sub> on an oscilloscope with the RC<sub>VCO</sub> pin shorted to ground. One should see the current waveform of Figure 5. Allowing the peak current sense pulse to reach an amplitude of 0.5V (by adjusting C<sub>SNS</sub>, and hence T<sub>ON</sub>) or, allowing the difference between the maximum and minimum of the 6 pulses to be >50mV, should suffice for adequate rotor position sensing. A good starting value for T<sub>ON</sub> is 200µs, requiring C<sub>SNS</sub> = 5.6nF.

## R<sub>INIT</sub>

The initial time interval between sample pulses during start-up is set by R<sub>INIT</sub>. This time interval (t<sub>INIT</sub>) occurs while the RC<sub>VCO</sub> pin is less than 0.25 volts.

$$R_{INIT} = \frac{3.43 t_{INIT}}{C_{VCO}}$$

STATE	DIRECTION	OUTPUTS						INPUT SAMPLES	
	REVERSE	N3	N2	N1	P3	P2	P1	FORWARD	REVERSE
	FORWARD	N1	N2	N3	P1	P2	P3		
A		OFF	OFF	ON	ON	OFF	OFF	PH2	PH2
B		OFF	OFF	ON	OFF	ON	OFF	PH1	PH3
C		ON	OFF	OFF	OFF	ON	OFF	PH3	PH1
D		ON	OFF	OFF	OFF	OFF	ON	PH2	PH2
E		OFF	ON	OFF	OFF	OFF	ON	PH1	PH3
F		OFF	ON	OFF	ON	OFF	OFF	PH3	PH1

Table 1. Commutation States.

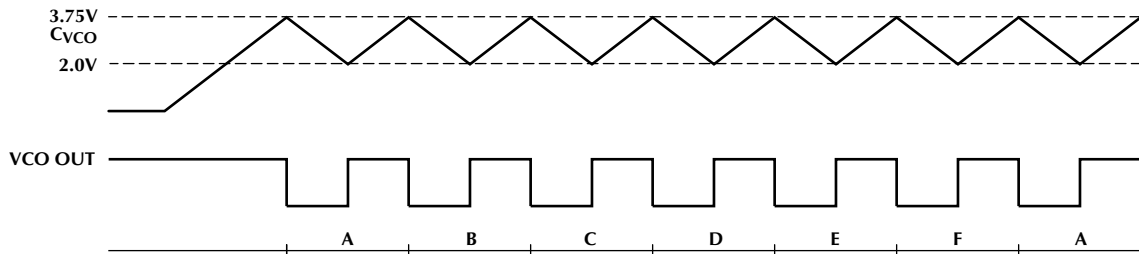

Figure 6. Commutation Timing and Sequencing.

START-UP SEQUENCING

When the motor is initially at rest, it is generating no back-EMF. Because a back-EMF signal is required for closed loop commutation, the motor must be started by other means until a velocity sufficient to generate some back-EMF is attained.

Start

For  $RC_{VCO}$  voltages of less than 0.6V the ML4428 will send 6 sample pulses to the motor to determine the rotor position and drive the proper windings to produce desired rotation. This will result in motor acceleration until the  $RC_{VCO}$  pin achieves 0.6V and closed loop operation begins. This technique results in zero reverse rotation and minimizes start-up time. The sample time pulses are set by  $C_{SNS}$  and the initial sample interval is set by  $R_{INIT}$ . This sense technique is not effective for air core motors, since a minimum of 30% inductance difference must occur when the motor moves.

Direction

The direction of motor rotation is controlled by the commutation states as given in Table 1. The state sequence is controlled by the F/R.

Run

When the  $RC_{VCO}$  pin exceeds 0.6V the device will enter run mode. At this time the motor speed should be about 8%  $FRPM_{MAX}$  and be high enough to generate a detectable BEMF and allow closed loop operation to begin. The commutation position compensation has been previously discussed.

The motor will continue to accelerate as long as the voltage on the  $RC_{VCO}$  is less than the voltage on  $V_{SPEED}$ . During this time the motor will receive full N-channel drive limited only by  $I_{LIMIT}$ . As the voltage on  $RC_{VCO}$  approaches that of  $V_{SPEED}$  the  $C_{ISC}$  capacitor will charge and begin to control the gate drive to the N-channel transistor by setting a level for comparison on the 25kHz PWM saw tooth waveform generated on  $C_{PWM}$ . The compensation of the speed loop is accomplished on  $C_{SC}$  and on  $C_{ISC}$  which are outputs of transconductance amplifiers with a  $gm = 2.3 \times 10^{-4} \lambda$ .

Speed Control

The speed control section of the ML4428 is detailed in Figure 8. The two transconductance amplifiers with outputs at  $C_{SC}$  and  $C_{ISC}$  each have a gm of 0.23mmhos. The bandwidth of the current feedback component of the speed control is set at  $C_{ISC}$  as follows:

$$f_{3dB} = \frac{2.3 \times 10^{-4}}{2\pi C_{ISC}} = \frac{3.66 \times 10^{-5}}{C_{ISC}}$$

For  $f_{3dB} = 50kHz$ ,  $C_{ISC}$  would be 730pF. The filter components on the  $C_{SC}$  pin set the dominant pole in the system and should have a bandwidth of about 10% of the position filter on the  $RC_{VCO}$  pin. Typically this is in the 1 to 10Hz range.

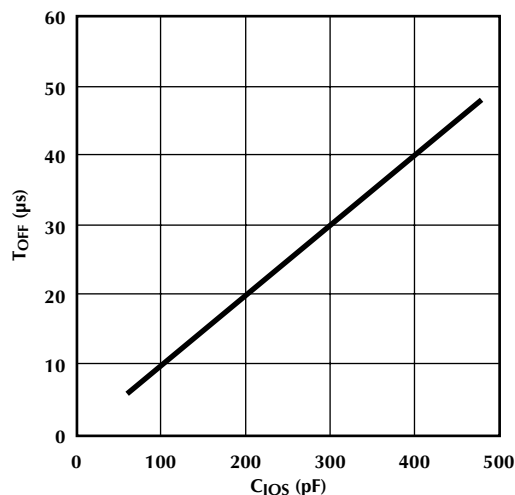

Note: 100pF gives 10 $\mu s$ , 200pF gives 20 $\mu s$ , etc.

$$\text{Slope} = \frac{dT}{C} = \frac{dV}{i} = \frac{5V}{50\mu A} = 100k\Omega$$

Figure 7.  $I_{LIMIT}$  Output Off-Time vs.  $C_{OS}$ .

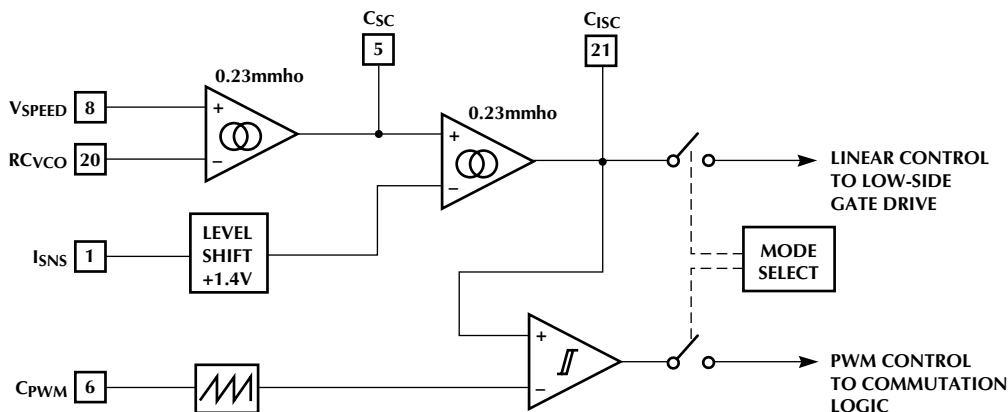

Figure 8. Speed Control Block Diagram.

## OUTPUT DRIVERS

The P-channel drivers are emitter follower type with 5mA pull down currents. The N-channel drivers are totem pole with a 1200 $\Omega$  resistor in series with the pull up device. Crossover comparators are employed with each driver pair, eliminating the potential of crossover, and hence, shoot-through currents.

## BRAKING

When  $\overline{\text{BRAKE}}$  is pulled low all 3 P-channel drivers will be turned off and all 3 N-channel drivers will be turned on.

## POWER FAIL

In the event of a power fail, i.e.  $V_{CC}$  falls below 8.75V all 6 output drivers will be turned off.

## HIGHER VOLTAGE MOTOR DRIVE

The ML4428 can be used to drive higher voltage motors by means of level shifters to the high side drive transistors. This can be accomplished by using dedicated high side drivers for applications greater than 80V or a simple NPN level shift as shown in Figure 9 for applications below 80V. Figure 10 shows how to interface to the IR2118, high side drivers from I.R. This allows driving motors up to 600V. The  $\overline{\text{BRAKE}}$  pin can be pulsed prior to startup with an RC circuit. This charges the bootstrap capacitors for three inexpensive high side drivers

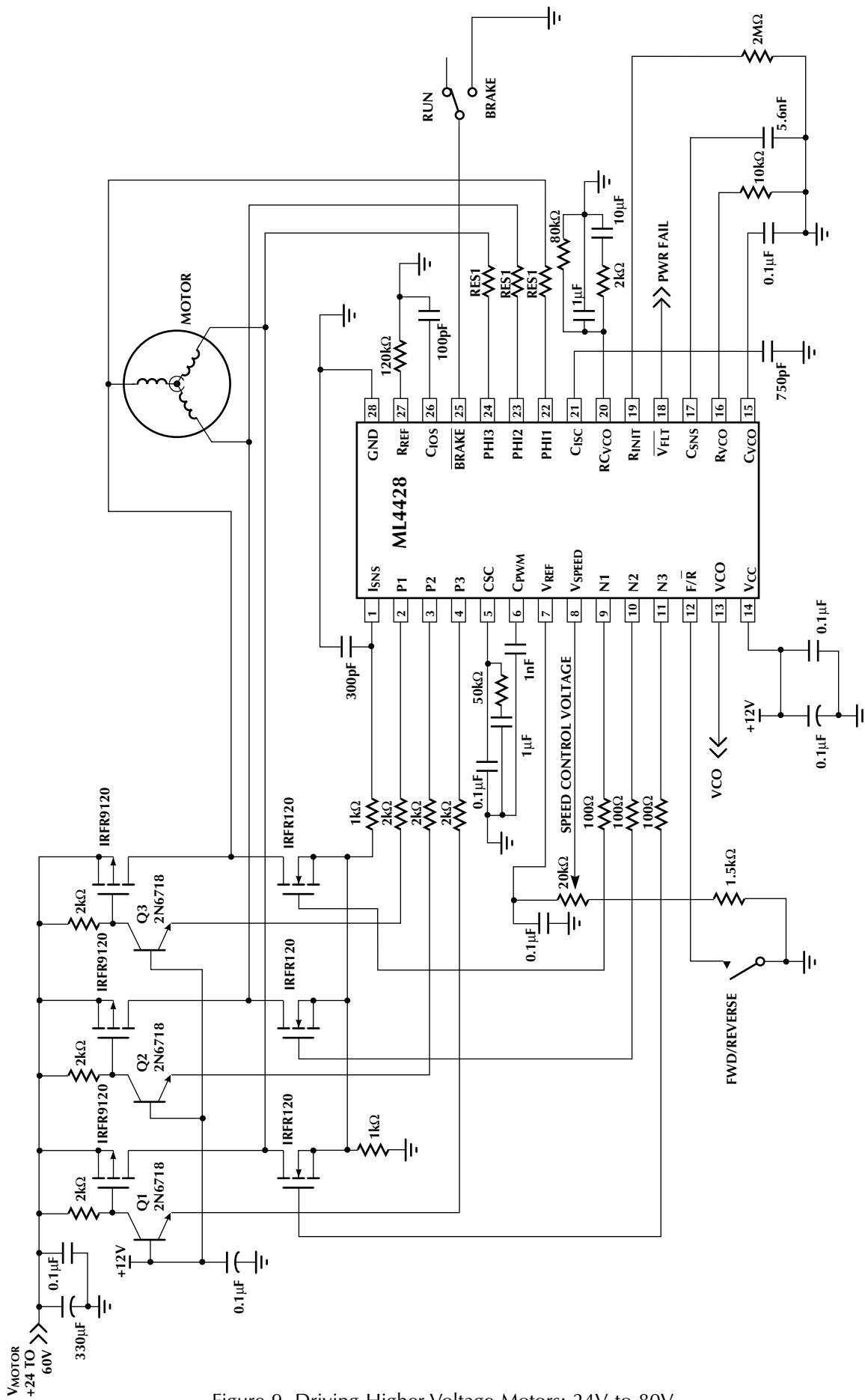

Figure 9. Driving Higher Voltage Motors: 24V to 80V.

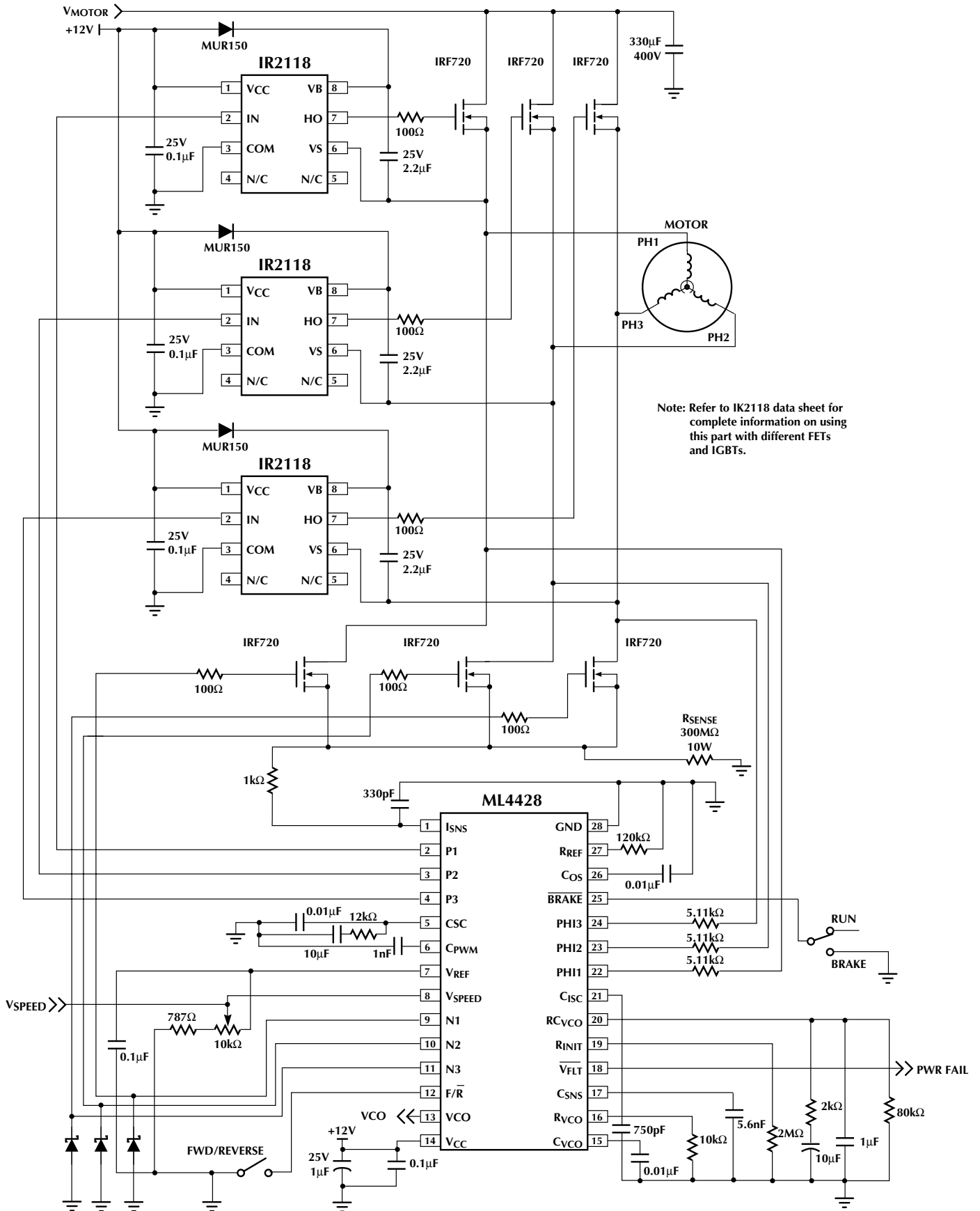
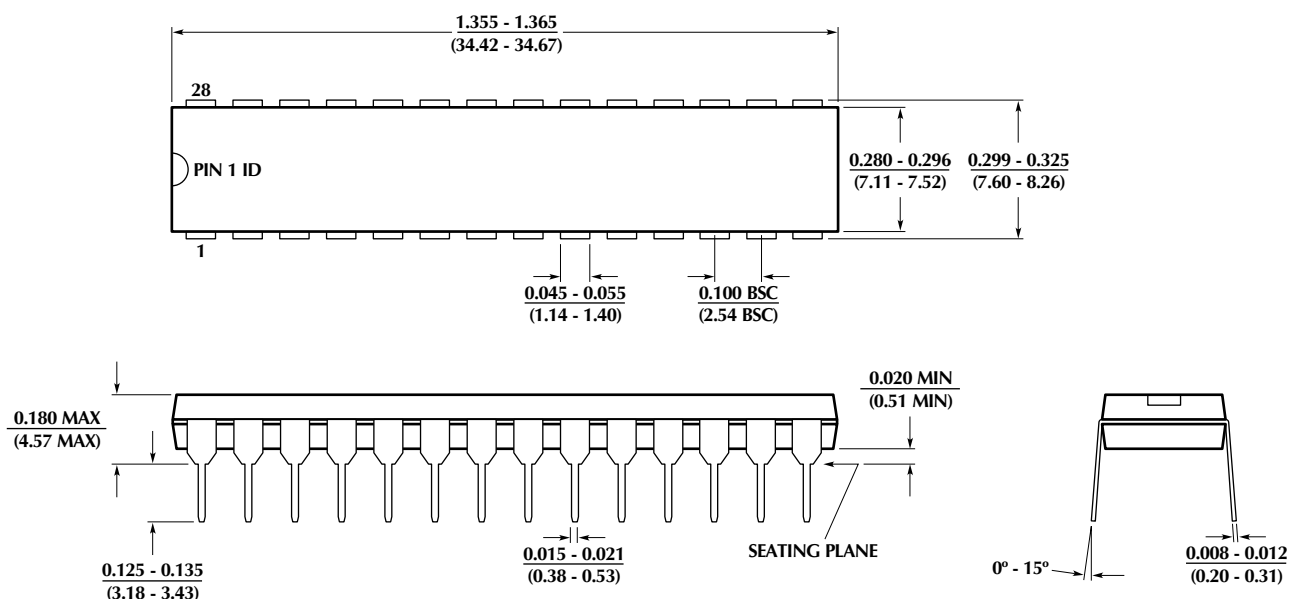

Figure 11. ML4428 High Voltage Motor Driver: 12V to 500V

PHYSICAL DIMENSIONS inches (millimeters)

Package: P28N  
28-Pin Narrow PDIP



## PHYSICAL DIMENSIONS inches (millimeters)

### Package: S28 28-Pin SOIC

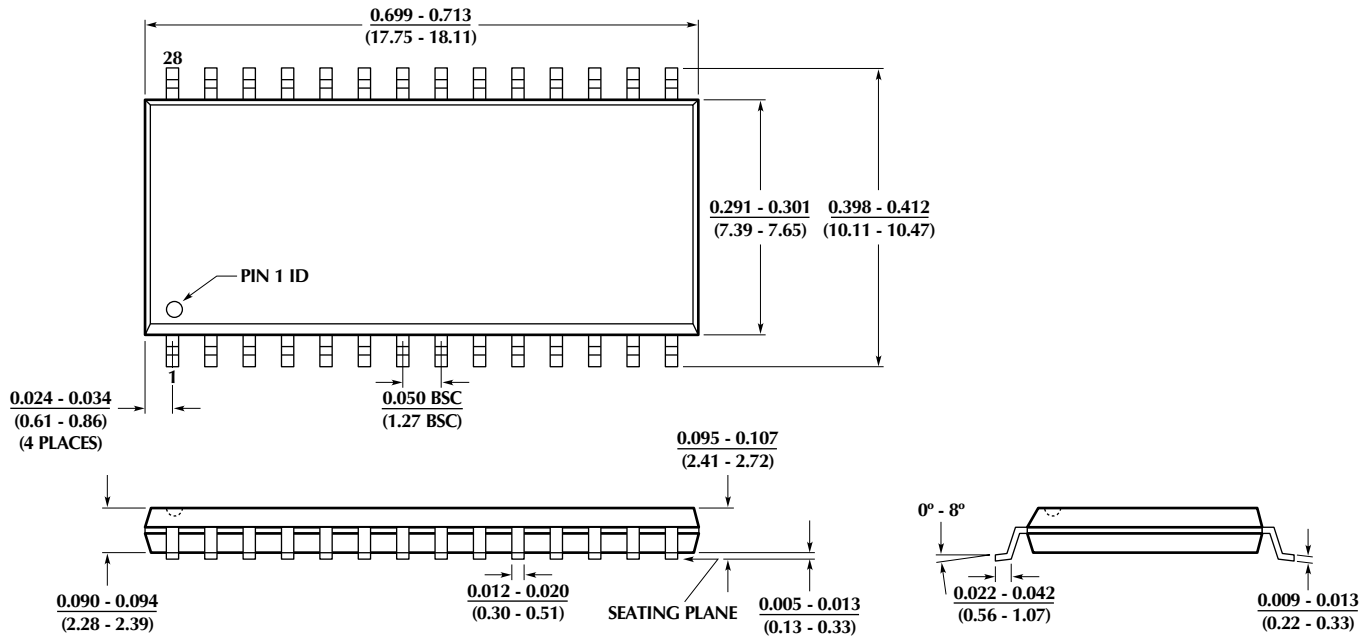

## ORDERING INFORMATION

PART NUMBER	TEMPERATURE RANGE	PACKAGE
<b>ML4428CP (EOL)</b> <b>ML4428CS (EOL)</b>	<b>0°C to 70°C</b> <b>0°C to 70°C</b>	<b>28-Pin DIP (P28N)</b> <b>28-Pin SOIC (S28)</b>
ML4428IP ML4428IS	-40°C to 85°C -40°C to 85°C	28-Pin DIP (P28N) 28-Pin SOIC (S28)

© Micro Linear 1997. **Micro Linear** is a registered trademark of Micro Linear Corporation.

Products described in this document may be covered by one or more of the following patents, U.S.: 4,897,611; 4,964,026; 5,027,116; 5,281,862; 5,283,483; 5,418,502; 5,508,570; 5,510,727; 5,523,940; 5,546,017; 5,559,470; 5,565,761; 5,592,128; 5,594,376; Japan: 2598946; 2619299. Other patents are pending.

Micro Linear reserves the right to make changes to any product herein to improve reliability, function or design. Micro Linear does not assume any liability arising out of the application or use of any product described herein, neither does it convey any license under its patent right nor the rights of others. The circuits contained in this data sheet are offered as possible applications only. Micro Linear makes no warranties or representations as to whether the illustrated circuits infringe any intellectual property rights of others, and will accept no responsibility or liability for use of any application herein. The customer is urged to consult with appropriate legal counsel before deciding on a particular application.

2092 Concourse Drive  
San Jose, CA 95131  
Tel: 408/433-5200  
Fax: 408/432-0295

This datasheet has been download from:

[www.datasheetcatalog.com](http://www.datasheetcatalog.com)

Datasheets for electronics components.